

Guide Post

European Standard

GP DIN9833

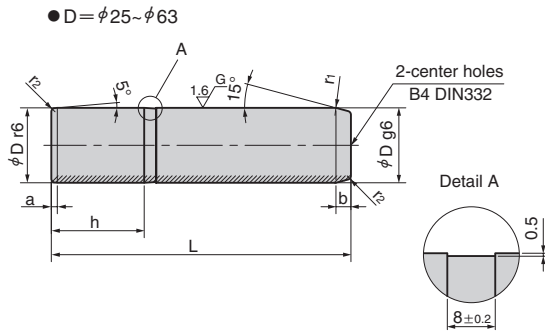

• D = $\phi 80 \sim \phi 160$

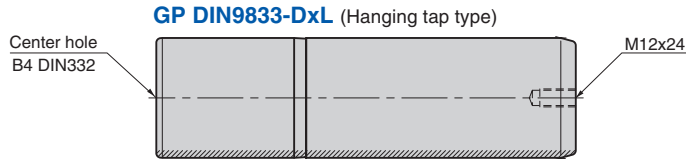

GP DIN9833-DxL-H (Hollow type)

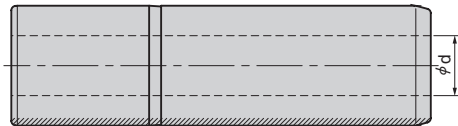

Solid type (Material) 42CrMo4V (S53C)
Hatched Area
HRC60 to 64
Depth 1.0 mm or more

Hollow type (Material) 1.3536 (S53C)
Hatched Area
HRC60 to 64
Depth 1.0 mm or more

Catalog No.	D	L
		125
	25	140
		160
		180
	32	140
		160
		180
		200
		140
		160
		180
GP DIN9833	40	200
		224
		250
		280
		160
		180
		200
	50	224
		250
		280
		315
		355

Catalog No.	D	L
		180
		200
		224
	63	250
		280
		315
		355
		400
		224
		250
		280
	80	315
		355
GP DIN9833		400
		280
	100	315
		355
		400
		315
		355
	125	400
		450
		500
		400
	160	450
		500
		560

D	Tolerance		h	a	b	r1	r2	d
	g6	r6						
25	-0.007 -0.020	+0.041 +0.028	40					
32			45		8	3	2	
40	-0.009 -0.025	+0.050 +0.034	56					—
50			70	4		5		
63	-0.010 -0.029	+0.060 +0.041	80			6	2.5	
80		+0.062 +0.043	100		10	8	3	40
100	-0.012 -0.034	+0.073 +0.051	125			10		50
125	-0.014 -0.039	+0.088 +0.063	140			12	4	65
160		+0.090 +0.065	180	5	12	18		95



Order

Catalog No. — D x L

GP DIN9833 — 50 x 250
GP DIN9833 — 80 x 280 (Hanging tap type)
GP DIN9833 — 80 x 400 — H (Hollow type)

Freeze the press fit area (Dr6) to -80°C for fitting.