

Flange Lifter

Side Mount Type

Panel Transfer Components

SOFLH50

CAD
FILE

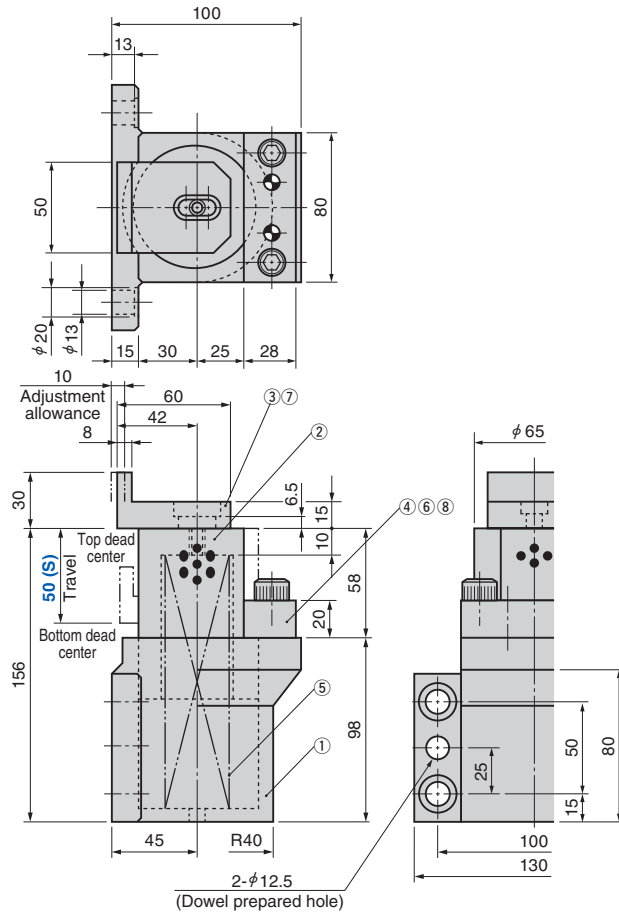

Catalog No.	S
SOFLH	50

Order	Catalog No.	S
	SOFLH	50

Spring Specifications

S	Spring Model	Initial		Final	
		Length [mm]	Load [N]	Length [mm]	Load [N]
50	TF35-150	138	160	88	810

Refer to page 329 for option parts.

No.	Description	Qty	Material and Remark
1	Casing	1	Cast Iron
2	Slide Pin	1	SO#50S20C
3	Lift Block	1	Steel
4	Stopper	1	Steel

No.	Description	Qty	Material and Remark
5	Spring	1	TF35-150
6	Hexagon Socket Head Bolt	2	M12x40
7	Hexagon Socket Head Bolt	1	M8x20
8	Dowel	2	SUJ2 φ 8x30