

Nest Gauge

Thickness 16 mm Regular Type

Gauge

NGLA
NGLSA (Gauge Hardening Type)

CAD FILE

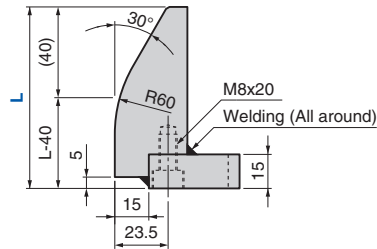
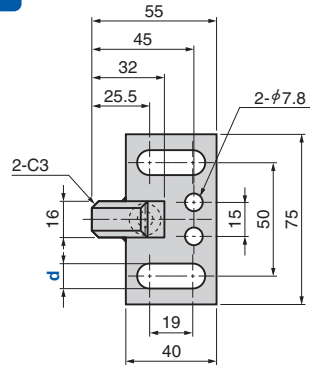

NGLR
NGLSR (Gauge Hardening Type)

CAD FILE

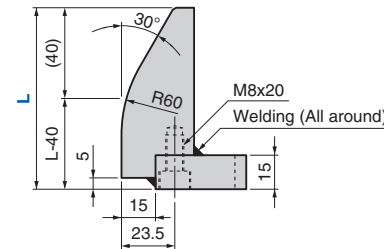
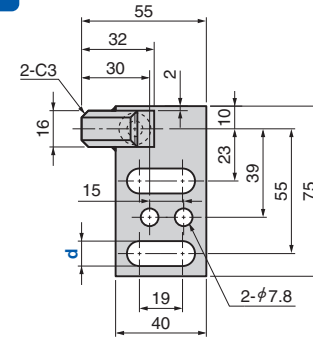

NGLL
NGLSL (Gauge Hardening Type)

CAD FILE

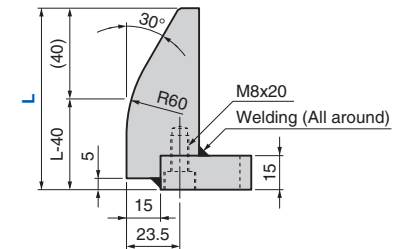
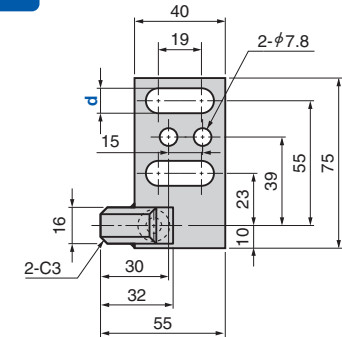

〈Material〉 Gauge S45C
Gauge base SS400
〈Accessory〉 Bolt M10 (M12) x30 2 pieces
Washer M10 (M12) 2 pieces

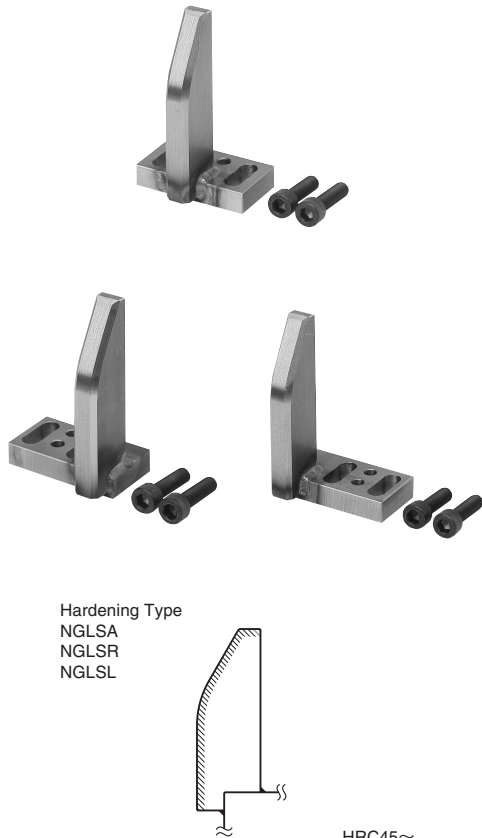

Hardening Type
NGLSA
NGLSR
NGLSL

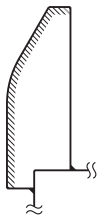

HRC45~
Hatched Area Hardening

Catalog No.	L 5 mm increments	d
NGLA NGLSA	65~100	11
NGLR NGLSR	105~150	13
NGLL NGLSL	155~200	



Order

Catalog No.	L	-	d
NGLA	135	-	11