

NEW

Sheet Support Gauge

Weight Adjusting Type for Rapid Production

Gauge

FKGNH

CAD FILE

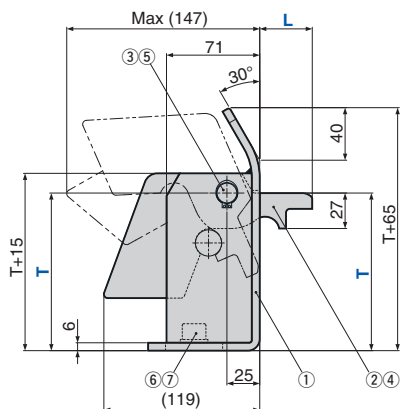
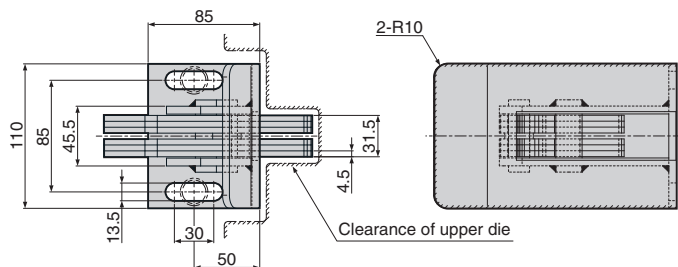

No.	Description	Qty	Material and Remark
1	Gauge	1	Steel
2	Support Plate	6	Steel
3	Fulcrum Hinge Pin	1	Steel
4	Collar	5	1 piece is assembled. 4 pieces are accompanied.
5	C Type Retaining Ring	2	φ 16 Shaft
6	Hexagon Socket Head Bolt	2	M12x30 (Accessory)
7	Washer	2	M12 (Accessory)

● Support Plate

Catalog No.	T	L
FKGNH	90	
	120	20
	150	40
	180	

Catalog No.	L
STLPH	20
	40

Workpiece guide block, which the previous model FKG had, is not installed in FKGNH. FKGNH with work guide block is upon request.



Catalog No.	T	-	L
FKGNH	90	-	40



Catalog No.	L
STLPH	20

■ Features

- Decreases the damage caused when setting a blank material.
- The number of support plates is adjustable up to 6 plates to equalize the weight of a blank material and support plates.

■ Design Guideline

- Approximately 10 mm of clearance is required on the upper die to avoid contacting the gauge body and support plates.
- The load of approximately 500 g per a plate is required to swing the support plates.

■ Exploded View

