

NEW Side Gauge Air Type

Gauge

SGATC

CAD
FILE

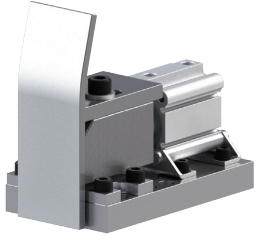

This figure shows SGATC with gauge.

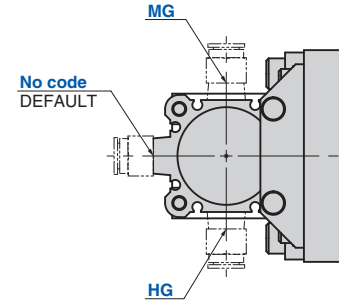
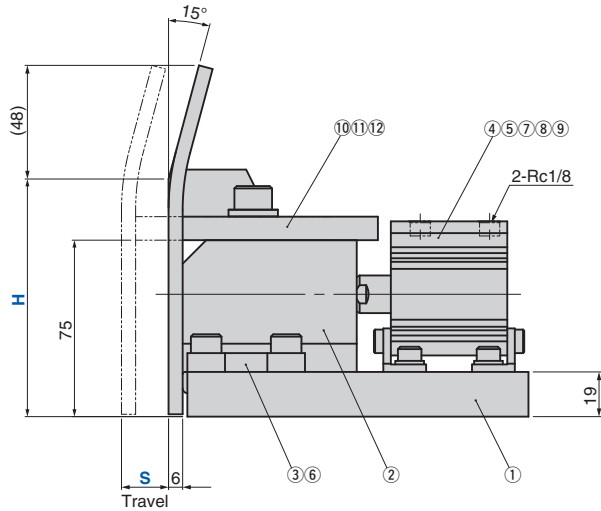
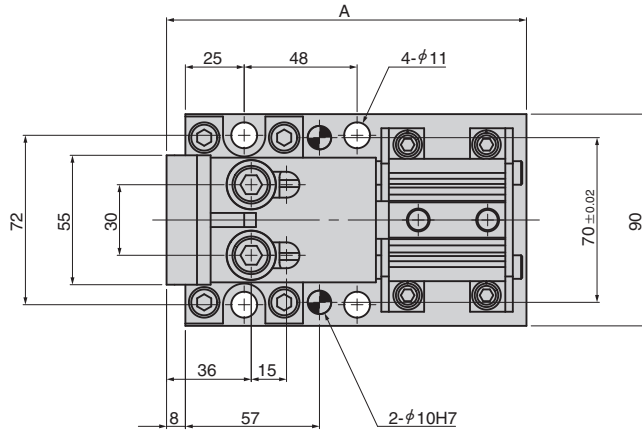

No.	Description	Qty	Material and Remark
1	Base Plate	1	Steel
2	Slide Holder	1	SO#50F
3	Guide Plate	2	Steel
4	Pusher Boss	1	Steel
5	Air Cylinder	1	SMC (φ 40)
6	Hexagon Socket Head Bolt	4	M8x20

No.	Description	Qty	Material and Remark
7	Hexagon Socket Head Bolt	4	M6x16
8	Spring Washer	4	M6
9	Split Pin	1	φ 4x30
10	Gauge	1	Steel
11	Washer	2	M10
12	Hexagon Socket Head Bolt	2	M10x35

Catalog No.	Travel S	Option			A
		H	Coupling Location G	Chrome Plating	
	05	75			138
		100	No code	No code	
SGATC	10	150	(Default)	(Without)	143
		200	HG	M	
	20	250	MG	(With)	153
	30	300			163



Without gauge

Catalog No. S - Option G

SGATC 10

SGATC 20 - HG

With gauge

Catalog No. S - Option H - Option G - Option Chrome Plating

SGATC 10 - 200

SGATC 20 - 250 - HG - M