

DA Gauge

Disappearing Gauge

Gauge

PKRGM

CAD
FILE

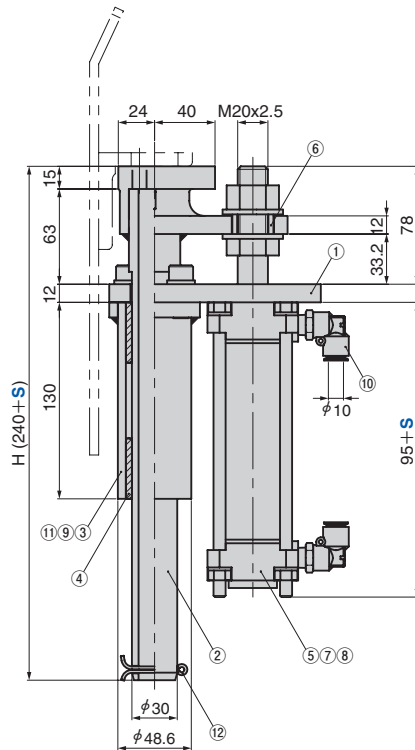
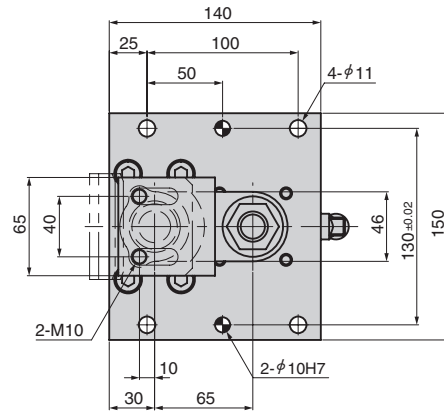
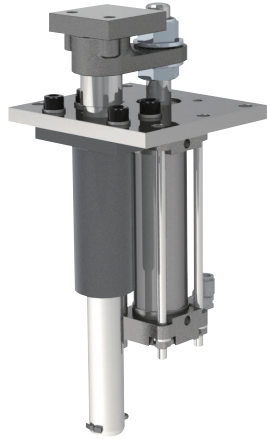

No.	Description	Qty	Material and Remark
1	Base Plate	1	Steel
2	Guide Post	1	Steel
3	Bushing Holder	1	Steel
4	Oilless Bushing	2	SOB
5	Air Cylinder	1	SMC (φ 40)
6	Collar	1	Steel
7	Flat Washer	2	M20
8	U Nut	1	M20
9	Hexagon Socket Head Bolt	4	M10x25
10	Elbow	2	—
11	Spring Washer	4	M10
12	Cotter pin	1	φ 5x40

Catalog No.	Cylinder Stroke S	H	Weight kg
PKRGM	100	340	6.7
	150	390	7.1



Catalog No.	S
PKRGM	150



<Blank in Open Position>

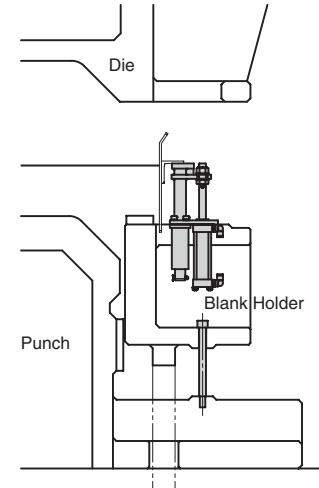

<Pre-form Position>

