

DA Gauge

Disappearing Gauge

Gauge

DABT

CAD
FILE

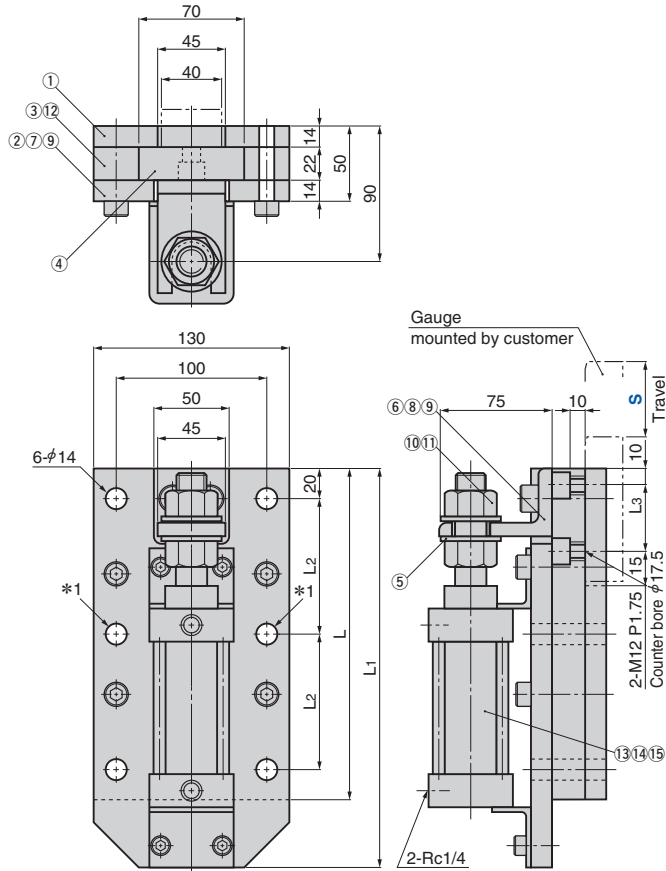

*1 This bolt hole is not available for DABT50.

No.	Description	Qty	Material and Remark
1	Base Plate	1	Steel
2	Cover Plate	1	Steel
3	Side Plate	2	Steel
4	Slide Plate	1	SO#50S45C
5	Collar	1	Steel
6	Arm	1	Steel
7	Hexagon Socket Head Bolt	4	M10x50
8	Hexagon Socket Head Bolt	2	M12x25

No.	Description	Qty	Material and Remark
9	Spring Washer	4	M10
10	Washer	2	—
11	Lock Nut	1	U nut
12	Dowel	4	ϕ 10x30
13	Spring Pin	1	ϕ 6x15
14	Hexagon Socket Head Bolt	4	M8x16
15	Air Cylinder	1	SMC (ϕ 40)

Catalog No.	S	L	L ₁	L ₂	L ₃	Weight kg
	50	220	265	90	25	13.5
DABT	100	270	315	115	45	15.9
	150	320	365	140	95	18.3



Order

Catalog No.	S
DABT	150

When Using Product

- Use DA gauge "DABT" as the panel locator for a draw die.
- Sliding areas have lubricant for oilless operation.
- The bolt holes of the sliding plate (④) are threaded so that the gauge may be mounted from the gauge side. (Dimension L₃)

Gauge