

Coil Support

Compact Type

Blanking Die Components

CLSPS (Steel Type)

CLSPJ (Resin Type)

CAD
FILE

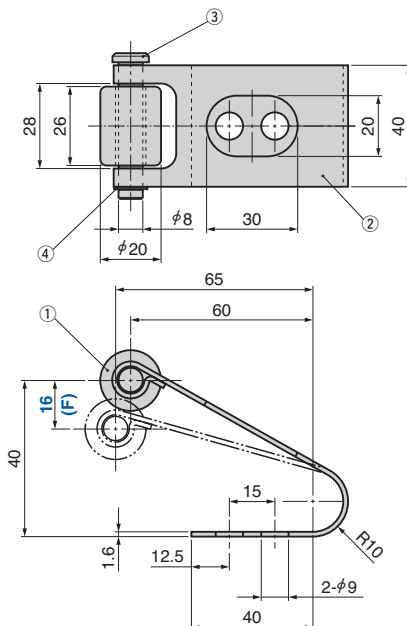

No.	Description	Qty	Material and Remark
1	Roller (Steel)	1	Steel
	Roller (Resin)		POM
2	Plate Spring	1	Steel
3	Hinge Pin	1	Steel
4	G type Retaining Ring	2	G-8
Accessory	Hexagon Socket Bolt	2	M8x20

Catalog No.	F max	Spring Constant N/mm (kgf/mm)
CLSPS	16	8.43 (0.86)
CLSPJ		

Travel F is max. 16. (Durability assurance range)



Catalog No.

CLSPS

F

16

