

Guide Roller Set

Blanking Die Components

GRASR
GRASL

CAD
FILE



- Load at reference position in operation 45.1N
- Load at assembly position 21.6N

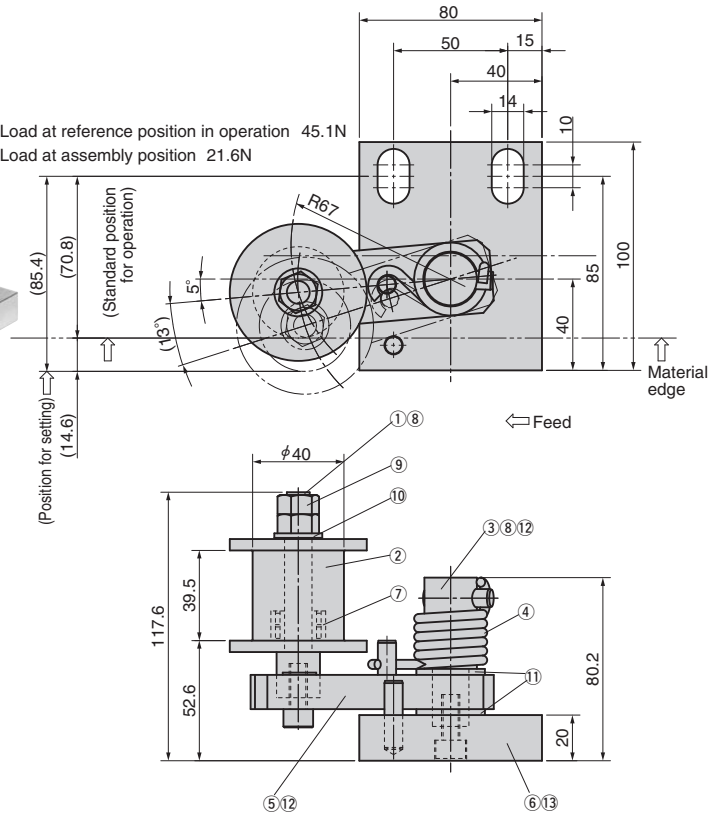

This illustration shows R Type GRASR.

GRBS

CAD
FILE

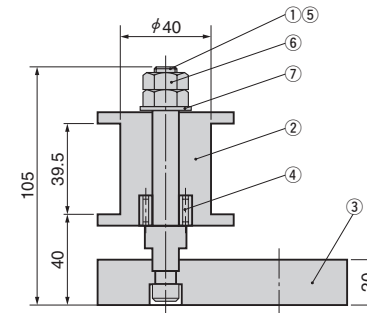
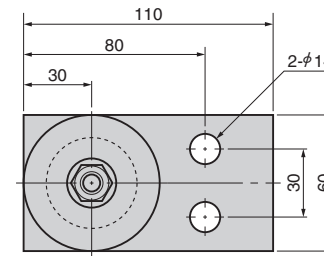

GRASR/GRASL

No.	Description	Qty	Material and Remark
1	Roller Set Pin	1	Steel
2	Guide Roller	1	Steel
3	Arm Set Pin	1	Steel
4	Spring	1	SWP-B
5	Roller Arm	1	Steel
6	Roller Base	1	Steel
7	Needle Bearing	1	NAG4901 by IKO
8	Hexagon Socket Head Bolt	2	M8x20
9	Hexagon Nut	2	M10
10	Washer	1	M10
11	Washer	2	M16
12	Dowel	2	φ8x30
13	Dowel Female Thread	1	φ8x30

GRBS

No.	Description	Qty	Material and Remark
1	Roller Set Pin	1	Steel
2	Guide Roller	1	Steel
3	Roller Base	1	Steel
4	Needle Bearing	1	NAG4901 by IKO
5	Hexagon Socket Head Bolt	1	M8x20
6	Hexagon Nut	2	M10
7	Washer	1	M10



Catalog No.

GRASR
GRBS



Example

