

Guide Bar

Counterbore Hole Type

Die Guide Components

GBSZ

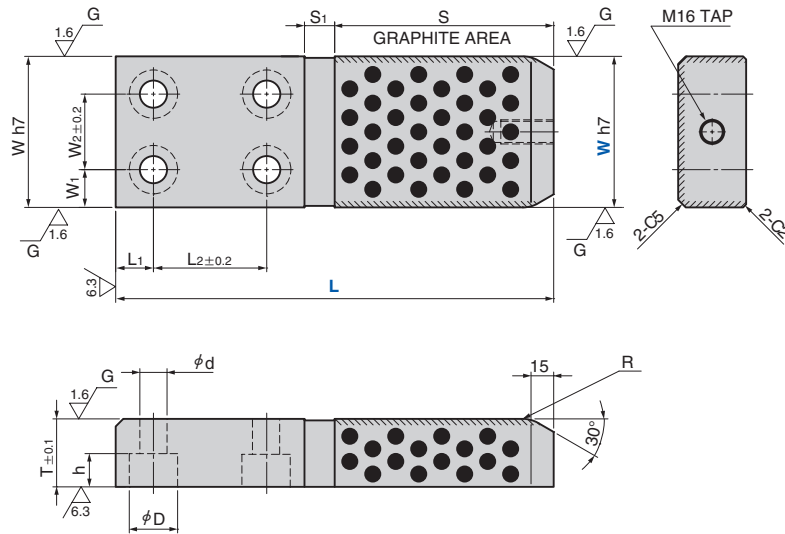

● Sliding Direction
↔

(Material) SO#50S45C
(Hardness) HRC40~
Hatched area to be
Induction Hardened

Catalog No.	W	L	W	h7	W ₁	W ₂	L ₁	L ₂	S	S ₁	D	d	h	T
GBSZ	125	330	125	0 -0.040	30	65	30	100	145	25	39	22	27	45
		360							175					
		390							205					
	150	390	150	90	125	175	30	235	55					
		420				205								
	450							235						



Catalog No. W - L
GBSZ 125 - 360