

Guide Post

Die Guide Components

SGP

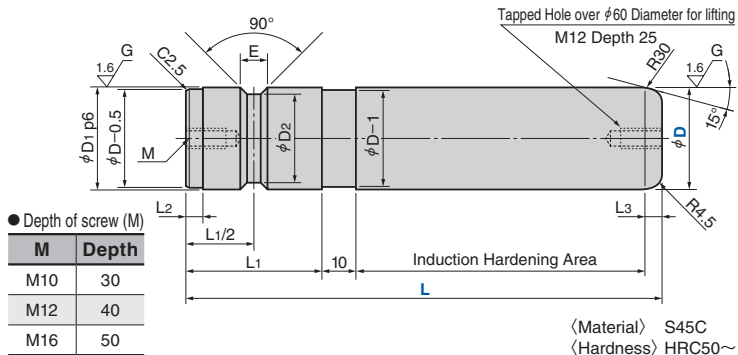

Catalog No.	D	L	D Tolerance	D1 p6	D2	L1	L2	L3	E	M	
SGP	25	80	25	25	21	30				10	
		100									
		120									
		140									
	30	100	30	30	26	40	5	5	8		
		140									
		160									
		180									
	40	120	40	-0.005 -0.015	36	50					12
		140									
		180									
		200									
50	160	50		45	70					10	
	200										
	250										
	300										
60	200	60		55	90						
	250										
	300										
	350										
65	250	65	-0.010 -0.025	60	100		10	10			
	300										
	350										
	250										
80	300	80		75	120				12	16	
	350										
	400										
	300										
100	350	100		95	150						
	400										



Catalog No. D - L