

Lifting Hooks

Die Setting Components

THH25~50

CAD FILE

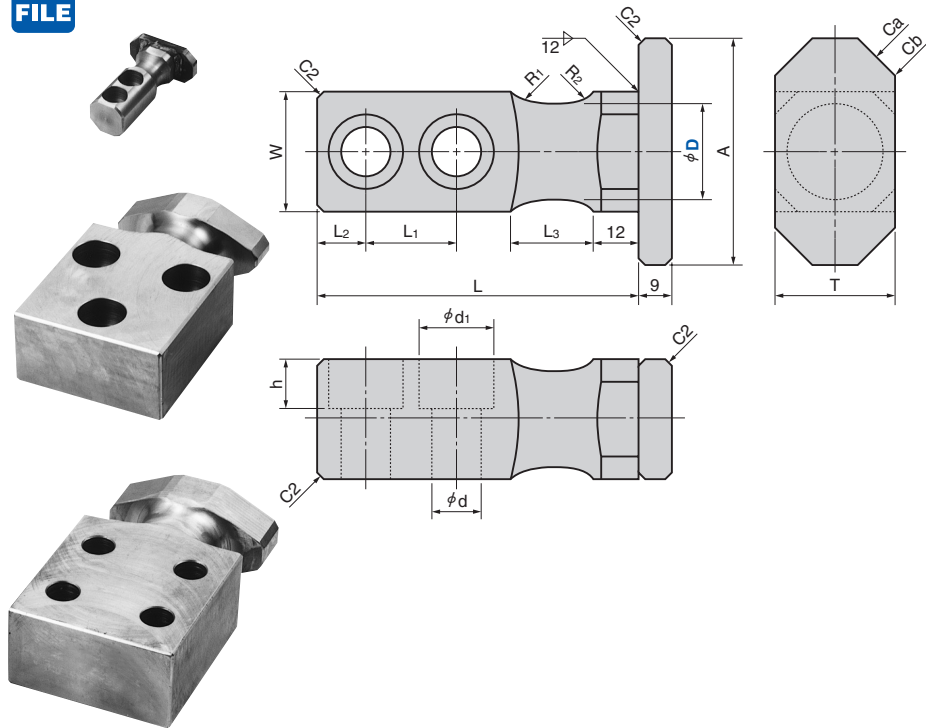

THH60

CAD FILE

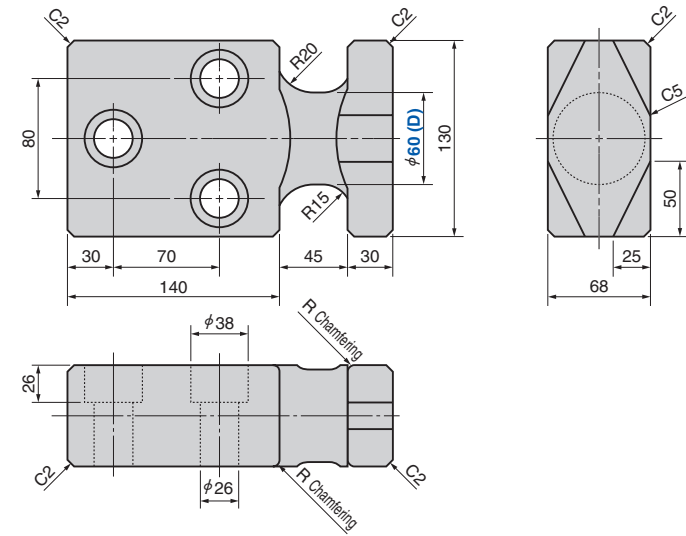

THH70

CAD FILE

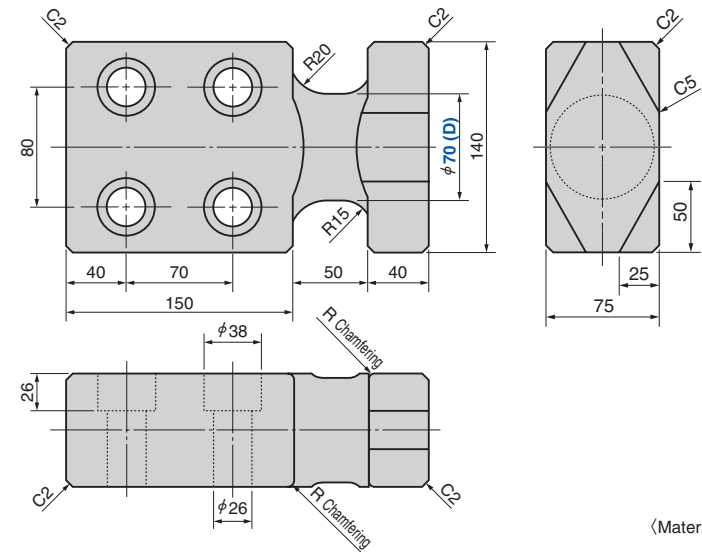

〈Material〉 SS400

⚠ After tightening mounting bolts, weld the circumference of the hook to the die.

Catalog No.	D	A	L	L ₁	L ₂	L ₃	W	R ₁	R ₂	d	d ₁	h	T	Ca	Cb	Allowable Load kgf/1P
THH	25	60	85	24	13	22	32	15	10	13	20	13	32	10	2	800
	32	80	120	44	16	32	40			18	26	18	40			1500
	40	90	140	52	18	40	50	22	32	22	50	2400				
	50	120	160	59	22	45	60	20	12	26	38	26	60	20	5	3500

Catalog No.	D	Allowable Load kgf/1P
THH	60	6000
	70	8000



Catalog No.
THH

D
60