

Locating Cone

Die Setting Components

SLTC

CAD FILE

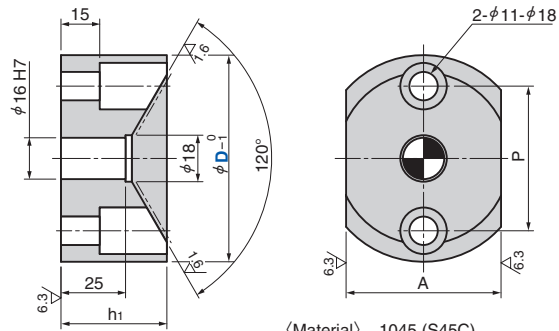
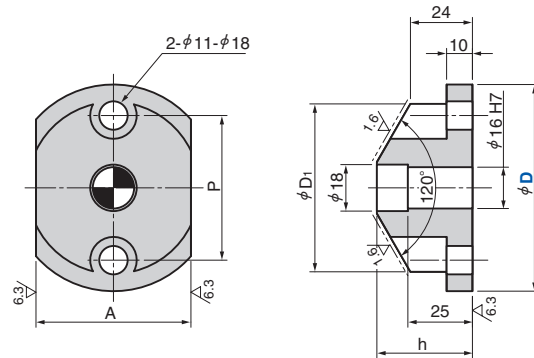

〈Material〉 1045 (S45C)
 〈Hardness〉 HRC50 or more
 The dotted line portion is
 Induction Hardened

● Accessory: Shim plate (This is to adjust height please use after grinding)

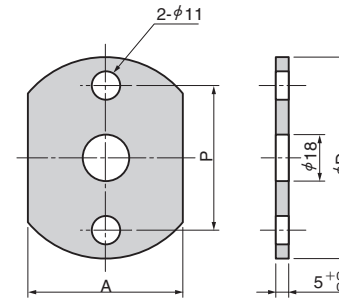

● Assembly drawing

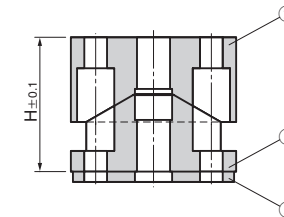

| No. | Description | Qty | Material and Remark |
|-----|-----------------------|-----|---------------------|
| 1 | Locating cone: Male | 1 | S45C |
| 2 | Locating cone: Female | 1 | S45C |
| 3 | Shim Plate | 1 | SS400 |

| Catalog No. | D | A | P | D ₁ | h | h ₁ | D ₂ | H |
|-------------|-----|----|----|----------------|----|----------------|----------------|----|
| SLTC | 80 | 60 | 56 | 65 | 37 | 41 | 79 | 65 |
| | 100 | 80 | 76 | 85 | 42 | 51 | 99 | 75 |



Catalog No. **SLTC**
 D **80**