

Oilless Slide Plate

Steel Type
Thickness 10 mm
SO#50SKS3



TSP



●W = 28 ~ 75

●W = 28 ●W = 38, 48, 75

●W = 100 or more

●Sliding Direction

Material Base SKS3
Solid lubricant (GR-1)
Hardness HRC58 or more
Accessory Special brazier head bolt

W1	W2	L1	L2	Catalog No.	W	L
		45				75
		50			28	100
		75				125
		100				150
		45				75
		50			38	100
		75				125
		100				150
		45				75
		50			48	100
		75		TSP		125
		100				150
		25				75
		50			75	100
		75				125
		100				150
		50				100
		75				125
		100				150
50	25	75	25		100	125
		100				150
		150				200
		75				125
	37.5	100	25		125	150

Order **Catalog No.** **W** - **L**
TSP 75 - 150

●Special brazier head bolt LCS10-20

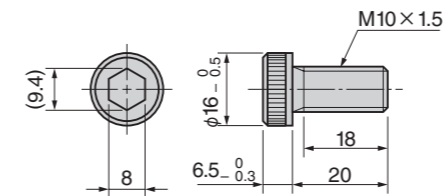

■ We are ready to accept requests or orders for special parts.

Operation Range

Lubricant Type	Lubricating Condition	Environment Condition	Max. Allowable Load P N/mm ²	Max. Allowable Sliding Speed V m/min	Max. Allowable PV value N/mm ² · m/min	Operation Range Temperature °C
GR-1	No lubrication	Atmosphere	50	10	80	-50 ~ +200
	Regular lubrication (Grease)			15		

▲ When the product is used at high temperature (150°C or more), the embedding specification of solid lubricant is different. Please contact us for details.

Physical Properties

Specific Gravity	Hardness HRC	Elongation %	Tensile Strength N/mm ²	Linear Expansion Coefficient × 10 ⁻⁵ /°C
7.8	58 or more	15 or more	800 or more	1.1