

# Cam Slide Guide

## V-Shaped Guide Type

NAAMS STANDARD

SNG99 (U Block)

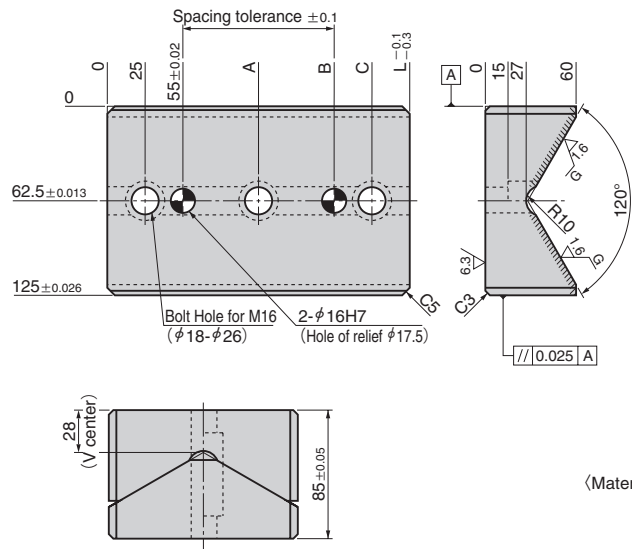

〈Material〉 1045 (S45C)  
Area to be Induction Hardened  
(Hatched Area)  
HRC55 to 60

Catalog No.	No. of Holes	L	A	B	C	NAAMS Code
SNG99	2	150	—	100	125	G991215
	2	200	—	150	175	G991220
	3	250	125	200	225	G991225
	3	300	150	250	275	G991230

SNG99 Series is made to order.

Order     
**SNG99 1225** (SNG991225)

SNG100 (V Block)

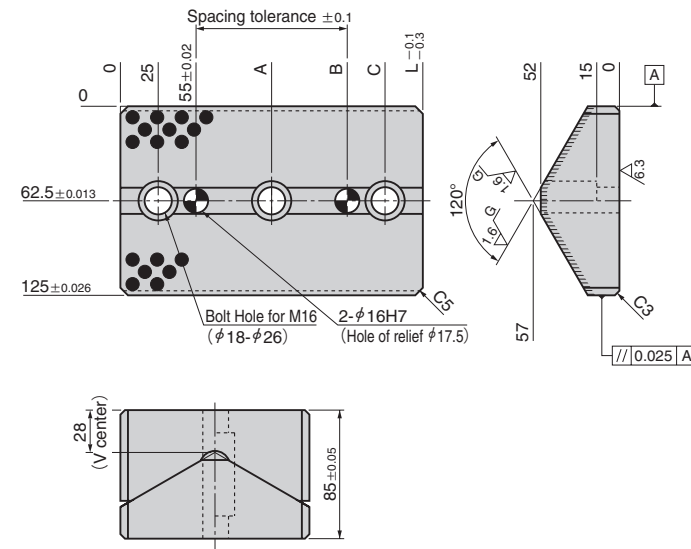
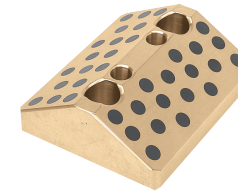

〈Material〉 SO#50SP2

Catalog No.	No. of Holes	L	A	B	C	NAAMS Code
SNG100	2	150	—	100	125	G1001215
	2	200	—	150	175	G1001220
	3	250	125	200	225	G1001225
	3	300	150	250	275	G1001230

SNG100 Series is made to order.

Order     
**SNG100 1225** (SNG1001225)