

RGBD (ストレートタイプ)

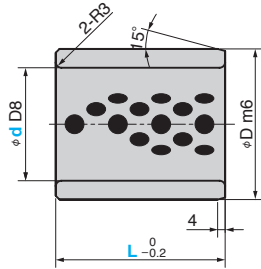

RGBTD (フランジタイプ)

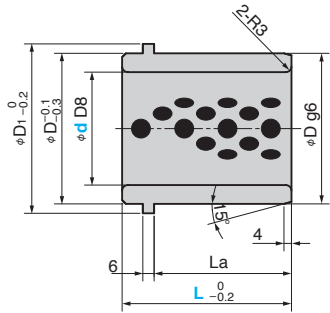

●スライド方向



・推奨穴加工公差 H7

材質 銅合金 (SP2)
オイルレス加工

■外径 ϕD 公差

D	公差		d D8	D	D ₁	La	Catalog No.	d	L
	RGBD 公差 m6	RGBTD 公差 g6							
80	+0.030	-0.010	60	80	90	53	RGBD	60	70
	+0.011	-0.029							73
100	+0.035 +0.013	-0.012 -0.034	80	100	110	+0.146 +0.100	RGBD RGBTD	80	100
									80
									120



Order

Catalog No.	d	L
RGBTD	60	90

■ガイドブッシュ抜け止めプレート (ストレートタイプ用)

GBSP

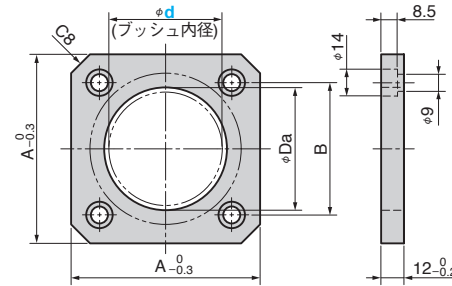

A	B	Da	ブッシュ 外径 D	Catalog No.	d
90	70	65	80	GBSP	60
110	90	85	100		80



Order

Catalog No.	d
GBSP	60

材質 S45C
表面処理 四三酸化鉄被膜

■ガイドブッシュ抜け止めクランプ (フランジタイプ用)

SNG

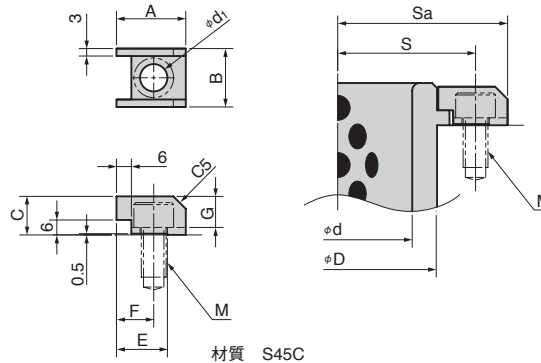

材質 S45C

ガイドブッシュ		M	S	Sa
d	D			
60	80	M8	54	65.1
		M10	55.5	68.4
80	100	M8	65	76.1
		M10	66.5	79.4

A	B	d ₁	C	E	F	G	M	Catalog No.
24.6	18.9	9	13	18	13.5	10	M8	SNG720000
27.9	23.5	11	15.5	20.5	15	12.5	M10	SNG730000



Order

Catalog No.
SNG730000