

SESW (銅合金スタンダードタイプ)

● W = 28 ~ 75

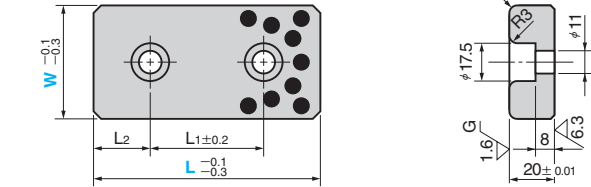

● W = 100 以上

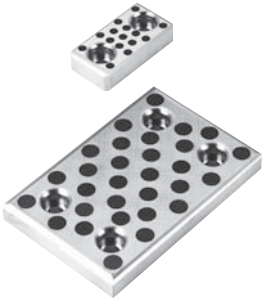
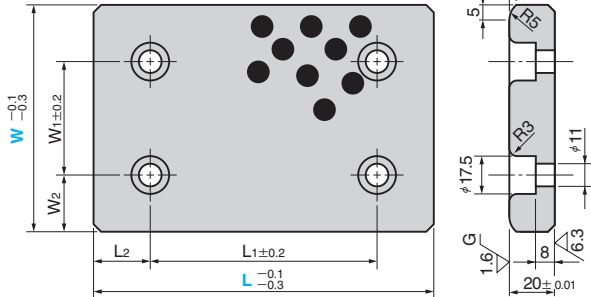

SESWT (銅合金・2穴タイプ)

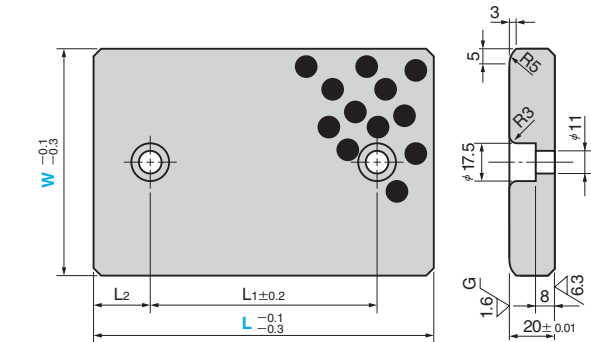
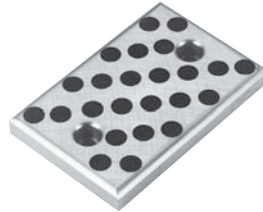

● スライド方向
W = 28・38



W = 48 以上

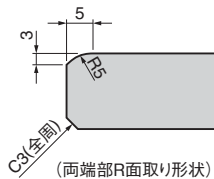

(両端部R面取り形状)

材質 銅合金 (SP2)
オイルレス加工

W1	W2	L1	L2	Catalog No.	W	L	
						SESW	SESWT
		45	15			75	
		50	25		28	100	
		100				150	
		45	15			75	
		50	25		38	100	
		100				150	
		45	15			75	
		50	25		48	100	
		75				125	
-	-	100	25	SESW		150	-
		150				200	
		45				75	
		50	15		58	100	
		100				150	
		25	25			75	
		50				100	
		75	25		75	125	
		100				150	
		150				200	
		50	50			100	100
		75				125	125
	25	100			100	150	150
		150	50			200	200
		200				250	250
50		75	25	SESW		125	125
		100			SESWT		150
	37.5	150	50		125	200	200
		200				250	250
		75				300	300
		100	25			150	150
		200				200	200
100	25	150	25		150	200	200
		200				250	250

※ W1、W2 は SESW (W=100 以上) のみの寸法値です。



Order

Catalog No.	W	-	L
SESW	38	-	100
SESWT	100	-	150

■ 特注品のご相談・ご注文も承ります。