

OILLESS ガイドブロック

GUIDE BLOCK

CAD FILE

SGBT

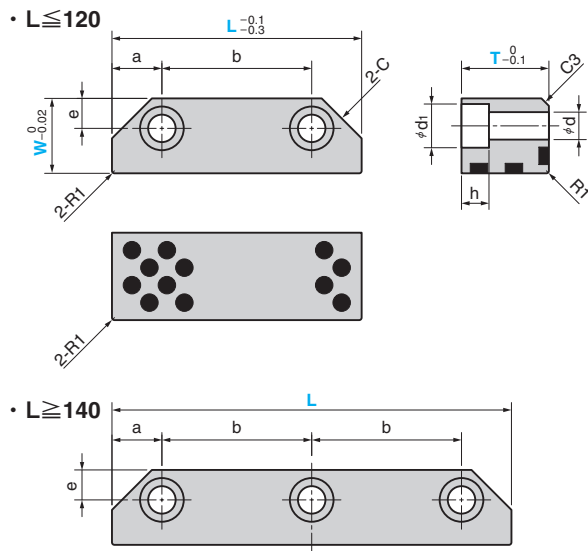

材質 銅合金 (SP2)
オイルレス加工

a	b	e	d	d ₁	h	C	Catalog No.	W	L	T
15	50	9	6.5	11	7	11	SGBT	20	80	20
	70								100	
	90								120	
	55								140	
	65								160	
17.5	45	10	9	14	9	13	SGBT	25	80	25
	65								100	
	85								120	
20	50	12	11	17.5	11	16	SGBT	30	140	30
	60								160	
	60								100	
	80								120	
20	50	12	11	17.5	11	16	SGBT	30	140	35
	60								160	
	70								180	

Order **Catalog No.** **W** - **L** - **T**
SGBT **25** - **120** - **30**

OILLESS ガイドブロック

GUIDE BLOCK

CAD FILE

SGBD

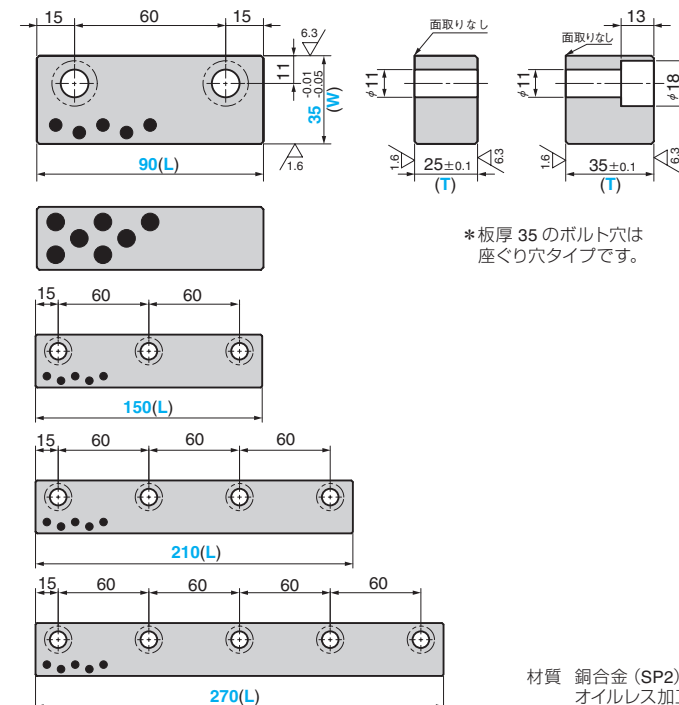

* 板厚 35 のボルト穴は
座ぐり穴タイプです。

材質 銅合金 (SP2)
オイルレス加工

Catalog No.	(W)	(L)	(T)
SGBD	35	90	25
		150	35
		210	35
		270	35

Order **Catalog No.** **(W)** - **(L)** - **(T)**
SGBD **35** - **150** - **25**
SGBD **35** - **270** - **35**



オプションコード	仕様
CM	C10 のコーナー逃がし用の面取加工を行います (2ヶ所)。ご注文の際には CM10 とご指示ください。

Order **SGBD 35 - 150 - 35 - CM10**

