

For Pierce and Flange

Aerial Cam Unit General Description of UCNBK

OUTLINE OF UCNBK

- High rigidity because of the box structure to keep the slider.
- V-shaped guide.
- 65, 100 and 200mm are available for the mounting width.
- Available angle is 0° to 70° at increments of 5°.

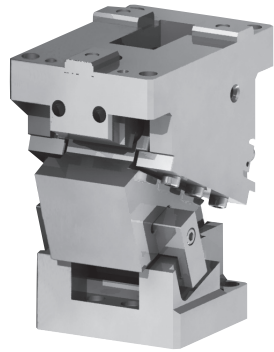

Option of UCNBK

Key Specification (-K)

UCNBK65

LKU25-100 (with 2-M8 bolts)

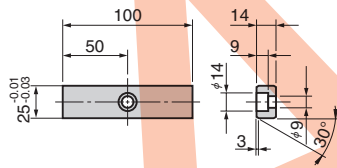

UCNBK100/200

LKU32-50 (with 3-M8 bolts)

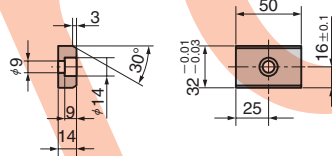

Metric Key Specification (-KA)

UCNBK100/200

LKE25-32-50 (with 3-M8 bolts)

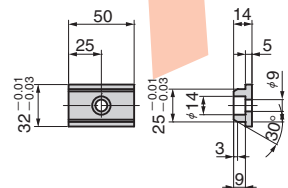

UCNBK Structure and Assembly / Disassembly

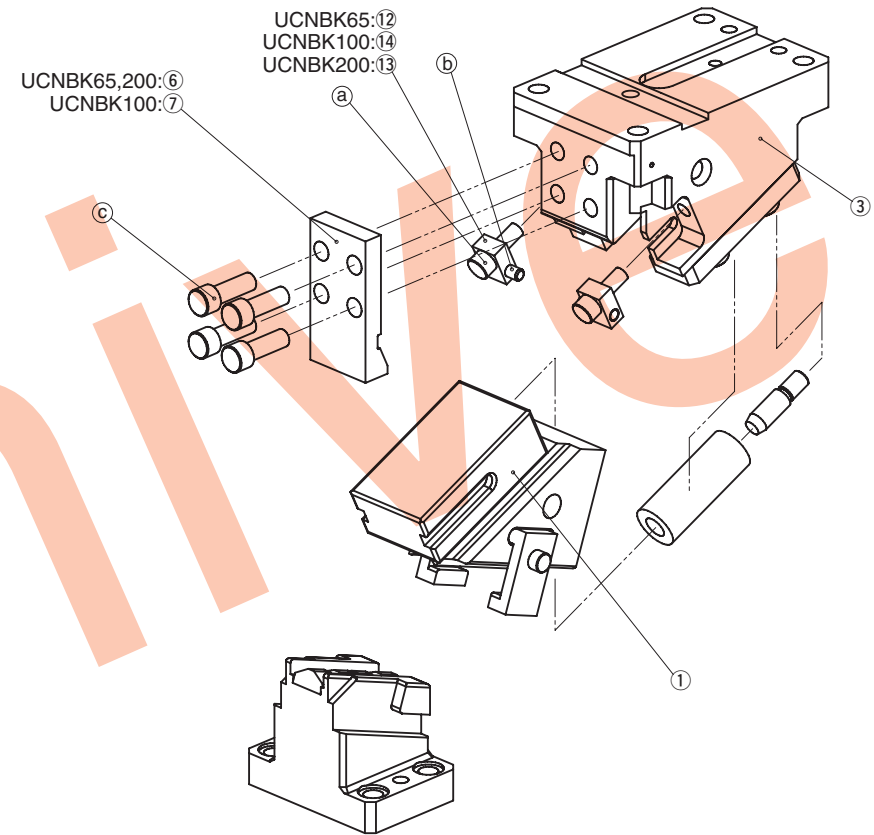

Disassembly method of UCNBK

- 1) Loosen hexagon socket head bolt (a) and remove plate (UCNBK65:12 UCNBK100:14 UCNBK200:13) and dowel pin (b).
- 2) Loosen hexagon socket head bolt (c) and remove stopper plate (UCNBK65,200:6 UCNBK100:7).
- 3) Pull and remove cam slider (1) from cam holder (3) to the rear.

Assembly method of UCNBK

- 1) Assemble components in the reverse order of disassembly.
 - Make sure that there is no foreign matter on the sliding area and assemble components.
 - The clearance between the cam slider and the cam holder is controlled. Match the stamped serial number on the holder and slider before assembly.
 - When cam is disassembled and then reassembled, please do not forget to assemble all bolts provided.

Aerial Cam Unit

FOR PIERCE AND FLANGE

CAD FILE

UCNBK200-00

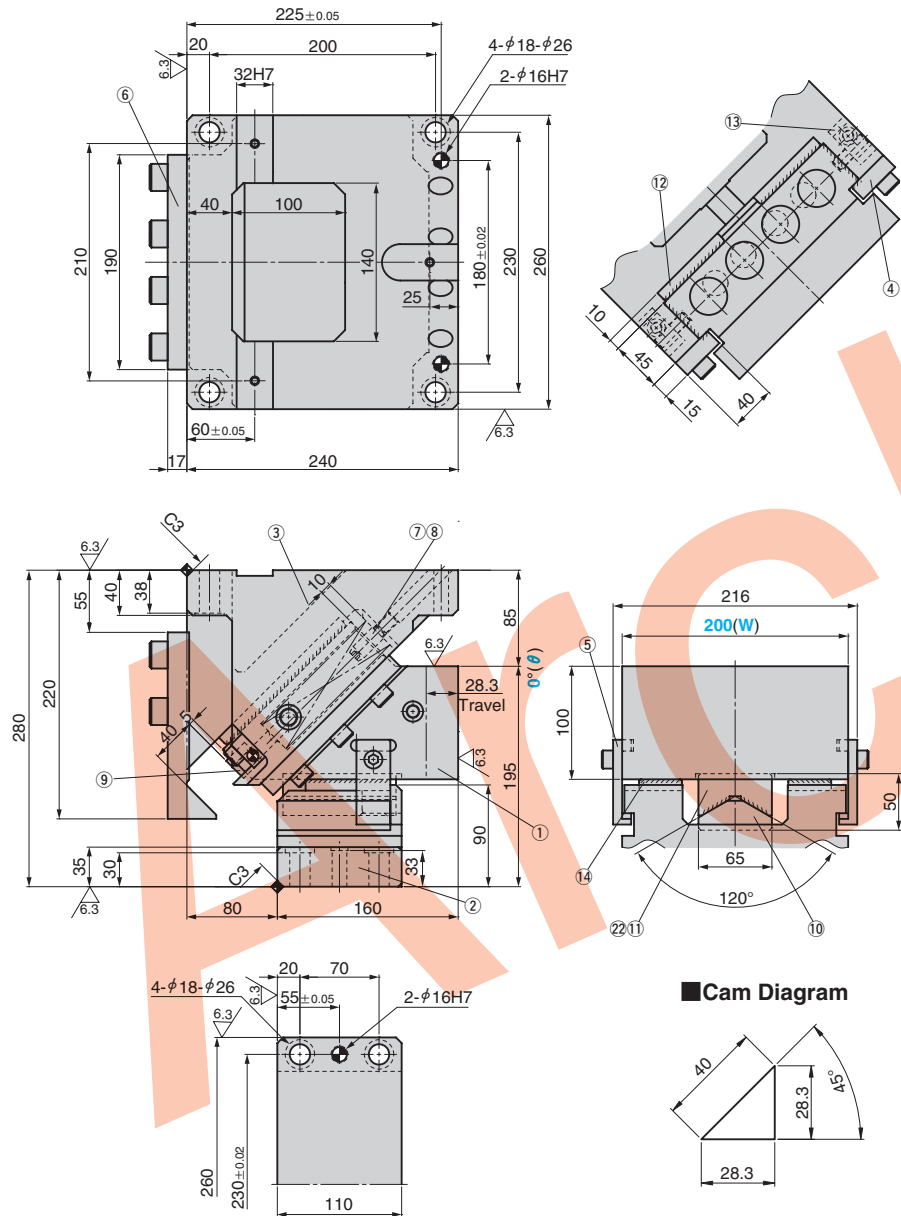

Travel S	Working Force kN(tonf)		Spring Force N(kgf)		Return Force N(kgf)	Slider Weight kg	Catalog No.	W	θ
	Standard Working Force (one million strokes)	Allowable Working Force (300,000 strokes)	Initial Load	Final Load					
28.3	93.1 (9.5)	186.2 (19.0)	626.0 (63.9)	5634.0 (574.9)	7119 (726.4)	26.0	UCNBK	200	00

Order **Catalog No.** **W** - **θ**
UCNBK 200 - 00

Option	Option Code	Specification
	K	Key attached for holder.
	KA	Metric key attached for holder.

For key specification, refer to page 737.

Order **UCNBK200-00-K**

Refer to page 389 for detailed specifications of tapped holes and dowel pin holes (prepared hole, finish hole) for retainer.

Table of Components

No.	Description	Qty	Material and Remark
①	Cam Slider	1	FC250 with Graphite
②	Cam Driver	1	FC250
③	Cam Holder	1	FC250
④	Upper Plate	2	S45C with Graphite
⑤	Positive Return Follower	2	S45C(1045)
⑥	Stopper Plate	1	S45C(1045)
⑦	Spring Guide Pin	4	SCM435
⑧	Coil Spring	4	TM30×175
⑨	Stopper	4	Urethane
⑩	Cam Bottom Slide Plate	1	S45C(1045)
⑪	Cam Bottom Guide Plate	1	Bronze with Graphite
⑫	Lower Plate	2	Bronze with Graphite
⑬	Plate	2	S45C(1045)
⑭	Driver Plate	2	Bronze with Graphite
⑮	Screw Plug	2	S45C M12

⚠ Bolts for assembly are not indicated.

Spring Diagram

- Spring used TM30-175 (4 piece)
- Spring constant 31.33N/mm (3.19kgf/mm)
- Guideline of spring durability 500,000 strokes

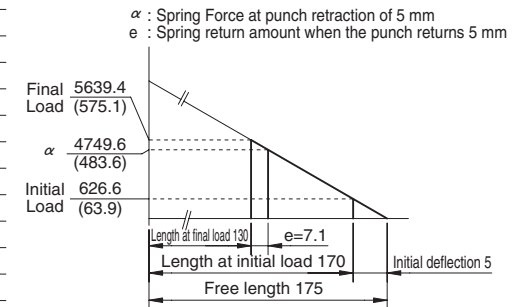

Space for removing

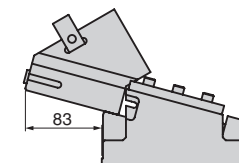

Aerial Cam Unit

FOR PIERCE AND FLANGE

CAD FILE

UCNBK200-05

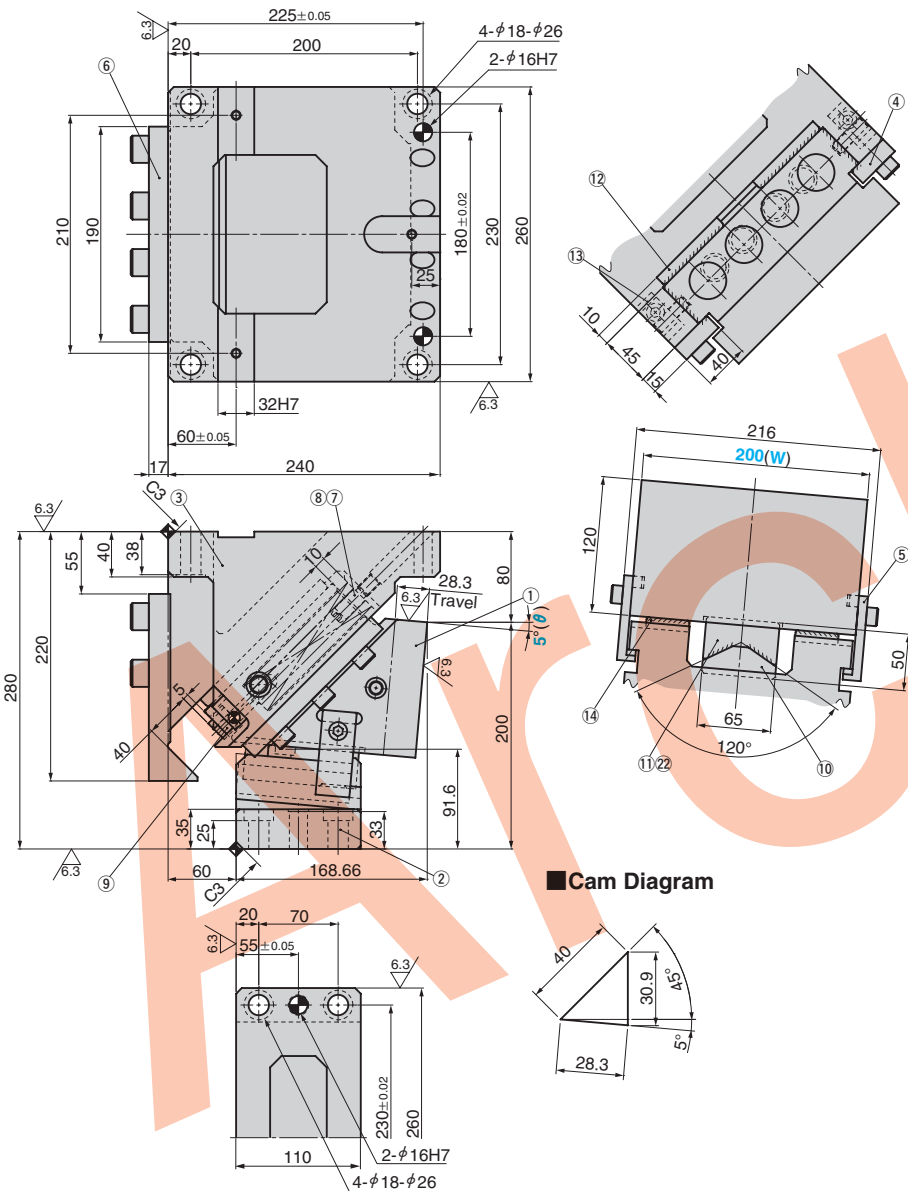

Cam Diagram

Travel S	Working Force kN(tonf)		Spring Force N(kgf)		Return Force N(kgf)	Slider Weight kg	Catalog No.	W	θ
	Standard Working Force (one million strokes)	Allowable Working Force (300,000 strokes)	Initial Load	Final Load					
28.3	93.1 (9.5)	186.2 (19.0)	626.6 (63.9)	5639.4 (575.1)	7675 (783.1)	30.4	UCNBK	200	05



Order

Catalog No. **UCNBK** W **200** - θ **05**



Option

Option Code	Specification
K	Key attached for holder.
KA	Metric key attached for holder.

For key specification, refer to page 737.



Order

UCNBK200-05-K

Refer to page 389 for detailed specifications of tapped holes and dowel pin holes (prepared hole, finish hole) for retainer.

Table of Components

No.	Description	Qty	Material and Remark
①	Cam Slider	1	FC250 with Graphite
②	Cam Driver	1	FC250
③	Cam Holder	1	FC250
④	Upper Plate	2	S45C with Graphite
⑤	Positive Return Follower	2	S45C(1045)
⑥	Stopper Plate	1	S45C(1045)
⑦	Spring Guide Pin	4	SCM435
⑧	Coil Spring	4	TM30×175
⑨	Stopper	4	Urethane
⑩	Cam Bottom Slide Plate	1	S45C(1045)
⑪	Cam Bottom Guide Plate	1	Bronze with Graphite
⑫	Lower Plate	2	Bronze with Graphite
⑬	Plate	2	S45C(1045)
⑭	Driver Plate	2	Bronze with Graphite
⑯	Screw Plug	2	S45C M12

Bolts for assembly are not indicated.

Spring Diagram

- Spring used TM30-175 (4 piece)
- Spring constant 31.33N/mm (3.19kgf/mm)
- Guideline of spring durability 500,000 strokes

α : Spring Force at punch retraction of 5 mm
e : Spring return amount when the punch returns 5 mm

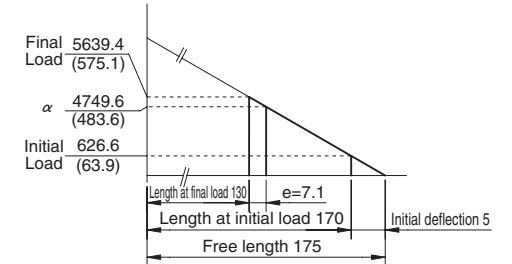

Space for removing

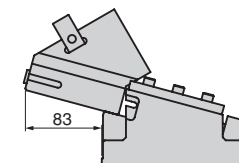

Aerial Cam Unit

FOR PIERCE AND FLANGE

CAD
FILE

UCNBK200-10

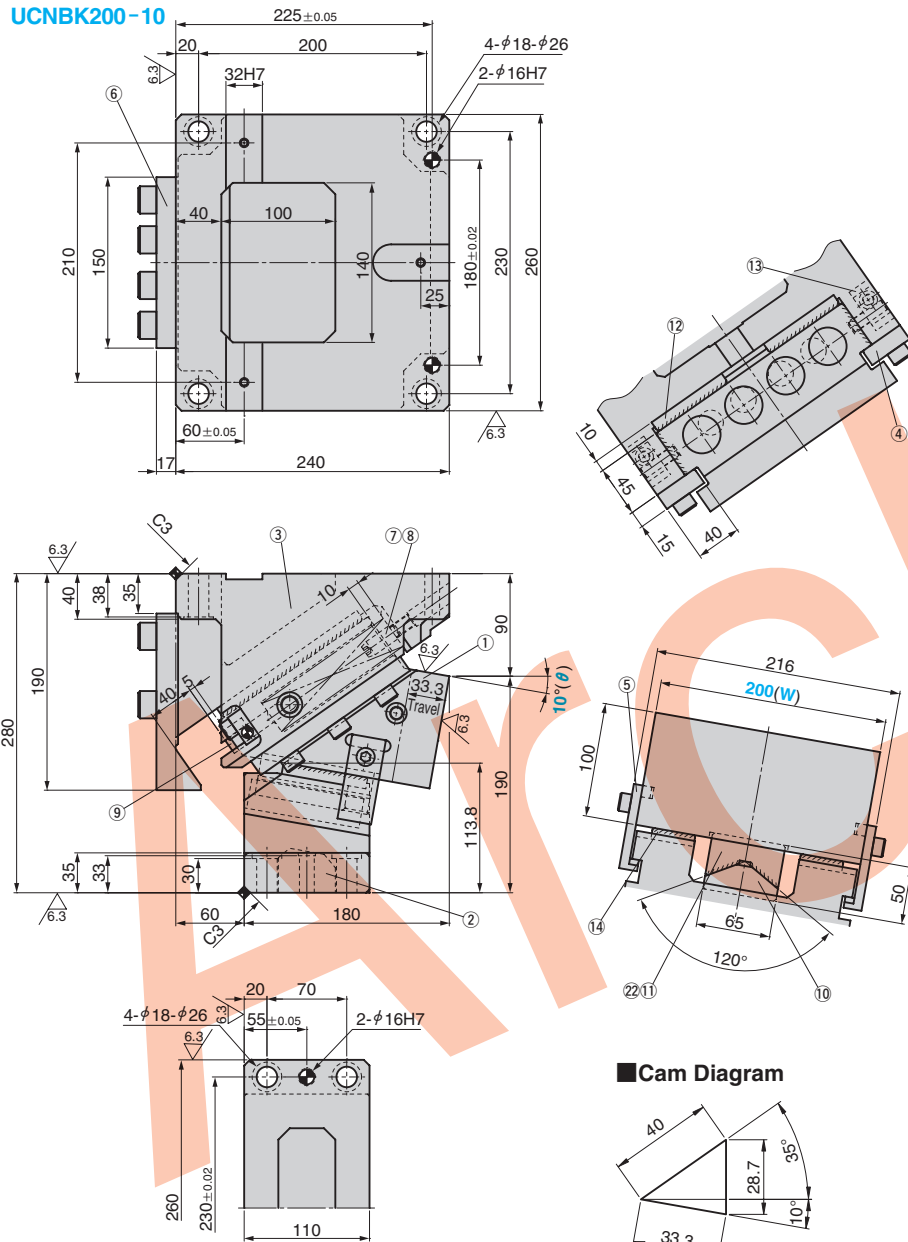

Cam Diagram

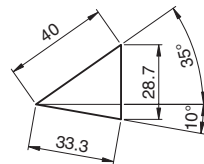

Travel S	Working Force kN(tonf)		Spring Force N(kgf)		Return Force N(kgf)	Slider Weight kg	Catalog No.	W	θ
	Standard Working Force (one million strokes)	Allowable Working Force (300,000 strokes)	Initial Load	Final Load					
33.3	93.1 (9.5)	186.2 (19.0)	626.6 (63.9)	5639.4 (575.1)	7066 (721.0)	24.8	UCNBK	200	10



Order

Catalog No.	W	θ
UCNBK	200	10



Option

Option Code	Specification
K	Key attached for holder.
KA	Metric key attached for holder.

For key specification, refer to page 737.



Order

UCNBK200-10-K

Refer to page 389 for detailed specifications of tapped holes and dowel pin holes (prepared hole, finish hole) for retainer.

Table of Components

No.	Description	Qty	Material and Remark
①	Cam Slider	1	FC250 with Graphite
②	Cam Driver	1	FC250
③	Cam Holder	1	FC250
④	Upper Plate	2	S45C with Graphite
⑤	Positive Return Follower	2	S45C(1045)
⑥	Stopper Plate	1	S45C(1045)
⑦	Spring Guide Pin	4	SCM435
⑧	Coil Spring	4	TM30×175
⑨	Stopper	4	Urethane
⑩	Cam Bottom Slide Plate	1	S45C(1045)
⑪	Cam Bottom Guide Plate	1	Bronze with Graphite
⑫	Lower Plate	2	Bronze with Graphite
⑬	Plate	2	S45C(1045)
⑭	Driver Plate	2	Bronze with Graphite
⑮	Screw Plug	2	S45C M12

Bolts for assembly are not indicated.

Spring Diagram

- Spring used TM30-175 (4 piece)
- Spring constant 31.33N/mm (3.19kgf/mm)
- Guideline of spring durability 500,000 strokes

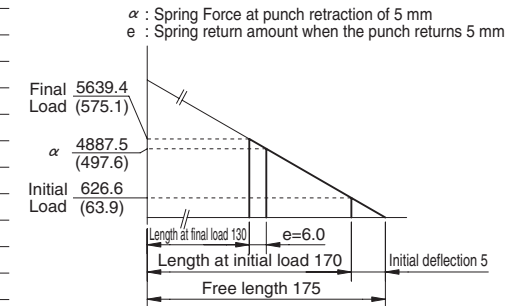

Space for removing

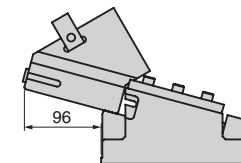

Aerial Cam Unit

FOR PIERCE AND FLANGE

CAD
FILE

UCNBK200-15

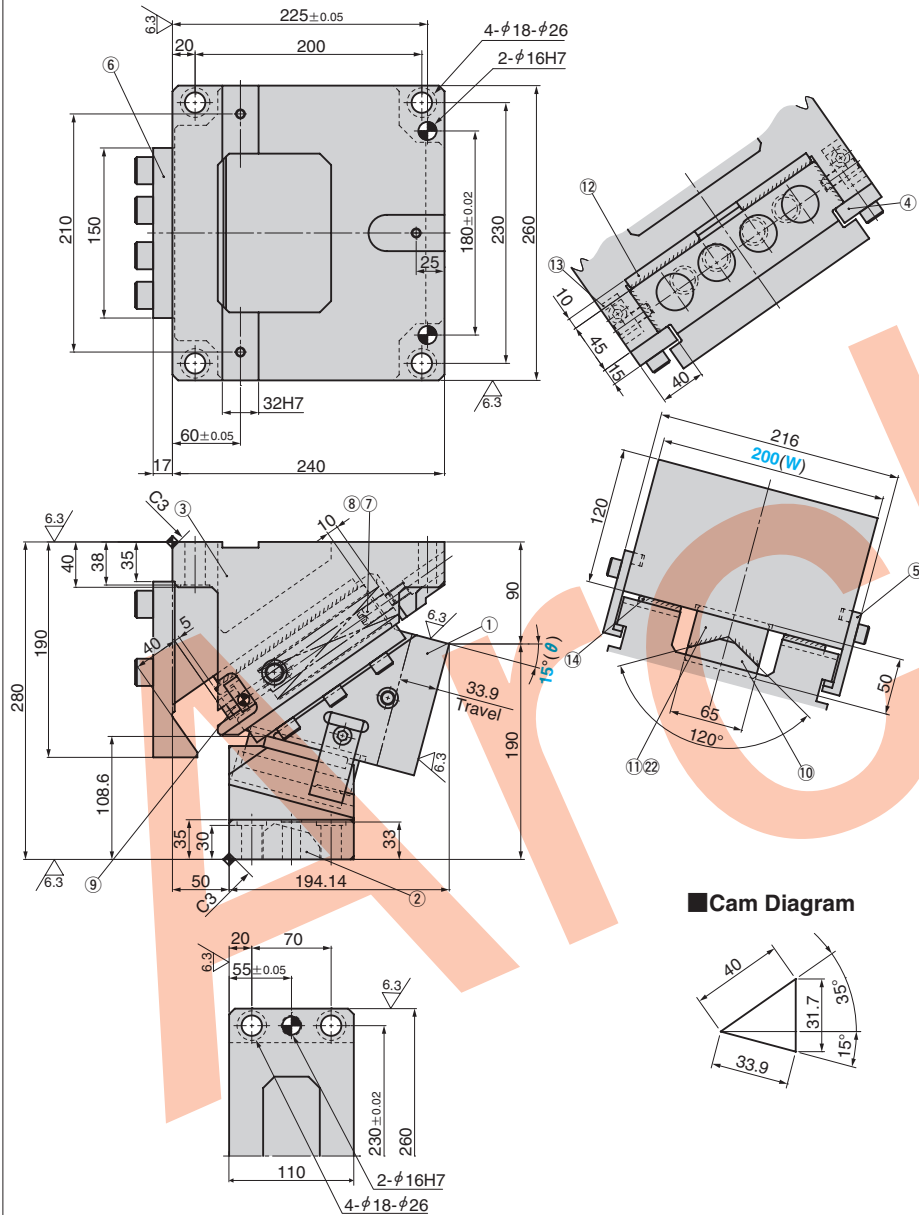

Cam Diagram

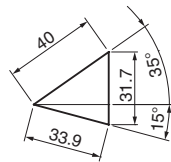

Travel S	Working Force kN(tonf)		Spring Force N(kgf)		Return Force N(kgf)	Slider Weight kg	Catalog No.	W	θ
	Standard Working Force (one million strokes)	Allowable Working Force (300,000 strokes)	Initial Load	Final Load					
33.9	93.1 (9.5)	186.2 (19.0)	626.6 (63.9)	5639.4 (575.1)	7617 (777.2)	30.6	UCNBK	200	15



Order

Catalog No.	W	θ
UCNBK	200	15



Option

Option Code	Specification
K	Key attached for holder.
KA	Metric key attached for holder.

For key specification, refer to page 737.



Order

UCNBK200-15-K

Refer to page 389 for detailed specifications of tapped holes and dowel pin holes (prepared hole, finish hole) for retainer.

Table of Components

No.	Description	Qty	Material and Remark
①	Cam Slider	1	FC250 with Graphite
②	Cam Driver	1	FC250
③	Cam Holder	1	FC250
④	Upper Plate	2	S45C with Graphite
⑤	Positive Return Follower	2	S45C(1045)
⑥	Stopper Plate	1	S45C(1045)
⑦	Spring Guide Pin	4	SCM435
⑧	Coil Spring	4	TM30×175
⑨	Stopper	4	Urethane
⑩	Cam Bottom Slide Plate	1	S45C(1045)
⑪	Cam Bottom Guide Plate	1	Bronze with Graphite
⑫	Lower Plate	2	Bronze with Graphite
⑬	Plate	2	S45C(1045)
⑭	Driver Plate	2	Bronze with Graphite
⑮	Screw Plug	2	S45C M12



Bolts for assembly are not indicated.

Spring Diagram

- Spring used TM30-175 (4 piece)
- Spring constant 31.33N/mm (3.19kgf/mm)
- Guideline of spring durability 500,000 strokes

α : Spring Force at punch retraction of 5 mm
e : Spring return amount when the punch returns 5 mm

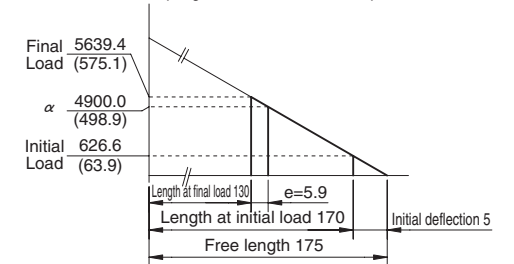

Space for removing

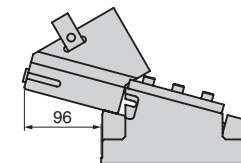

Aerial Cam Unit

FOR PIERCE AND FLANGE

CAD
FILE

UCNBK200-20

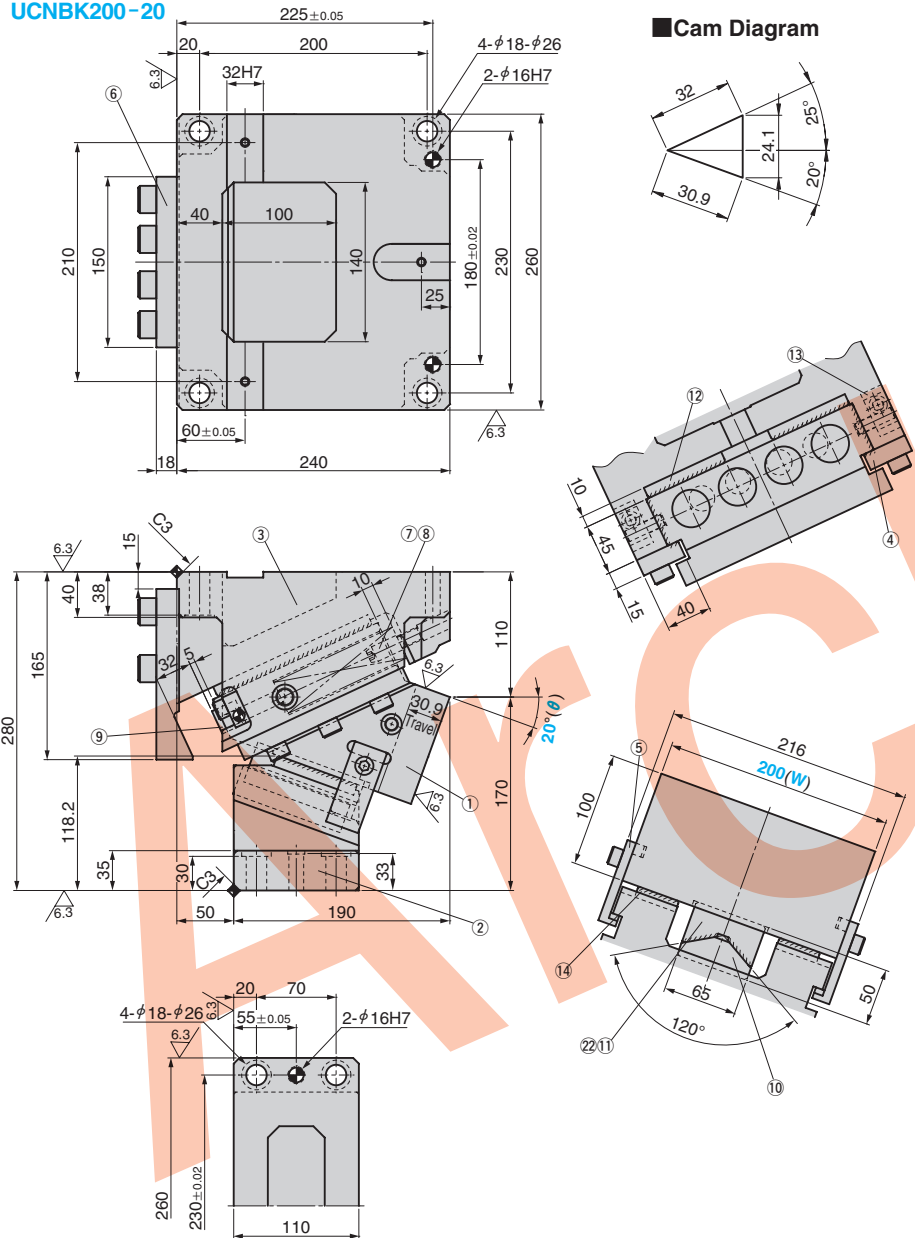

Travel S	Working Force kN(tonf)		Spring Force N(kgf)		Return Force N(kgf)	Slider Weight kg	Catalog No.	W	θ
	Standard Working Force (one million strokes)	Allowable Working Force (300,000 strokes)	Initial Load	Final Load					
30.9	93.1 (9.5)	186.2 (19.0)	438.6 (44.7)	5117.0 (521.8)	6378 (650.8)	25.9	UCNBK	200	20

Order **Catalog No.** **W** - **θ**
UCNBK 200 - 20

Option	Option Code	Specification
	K	Key attached for holder.
	KA	Metric key attached for holder.

For key specification, refer to page 737.

Order **UCNBK200-20-K**

Refer to page 389 for detailed specifications of tapped holes and dowel pin holes (prepared hole, finish hole) for retainer.

Table of Components

No.	Description	Qty	Material and Remark
①	Cam Slider	1	FC250 with Graphite
②	Cam Driver	1	FC250
③	Cam Holder	1	FC250
④	Upper Plate	2	S45C with Graphite
⑤	Positive Return Follower	2	S45C(1045)
⑥	Stopper Plate	1	S45C(1045)
⑦	Spring Guide Pin	4	SCM435
⑧	Coil Spring	4	TM30×150
⑨	Stopper	4	Urethane
⑩	Cam Bottom Slide Plate	1	S45C(1045)
⑪	Cam Bottom Guide Plate	1	Bronze with Graphite
⑫	Lower Plate	2	Bronze with Graphite
⑬	Plate	2	S45C(1045)
⑭	Driver Plate	2	Bronze with Graphite
⑯	Screw Plug	2	S45C M12

Bolts for assembly are not indicated.

Spring Diagram

- Spring used TM30-150 (4 piece)
- Spring constant 36.55N/mm (3.73kgf/mm)
- Guideline of spring durability 1,000,000 strokes

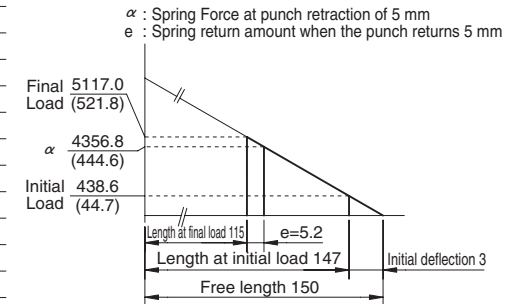

Space for removing

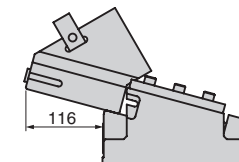

Aerial Cam Unit

FOR PIERCE AND FLANGE

CAD
FILE

UCNBK200-25

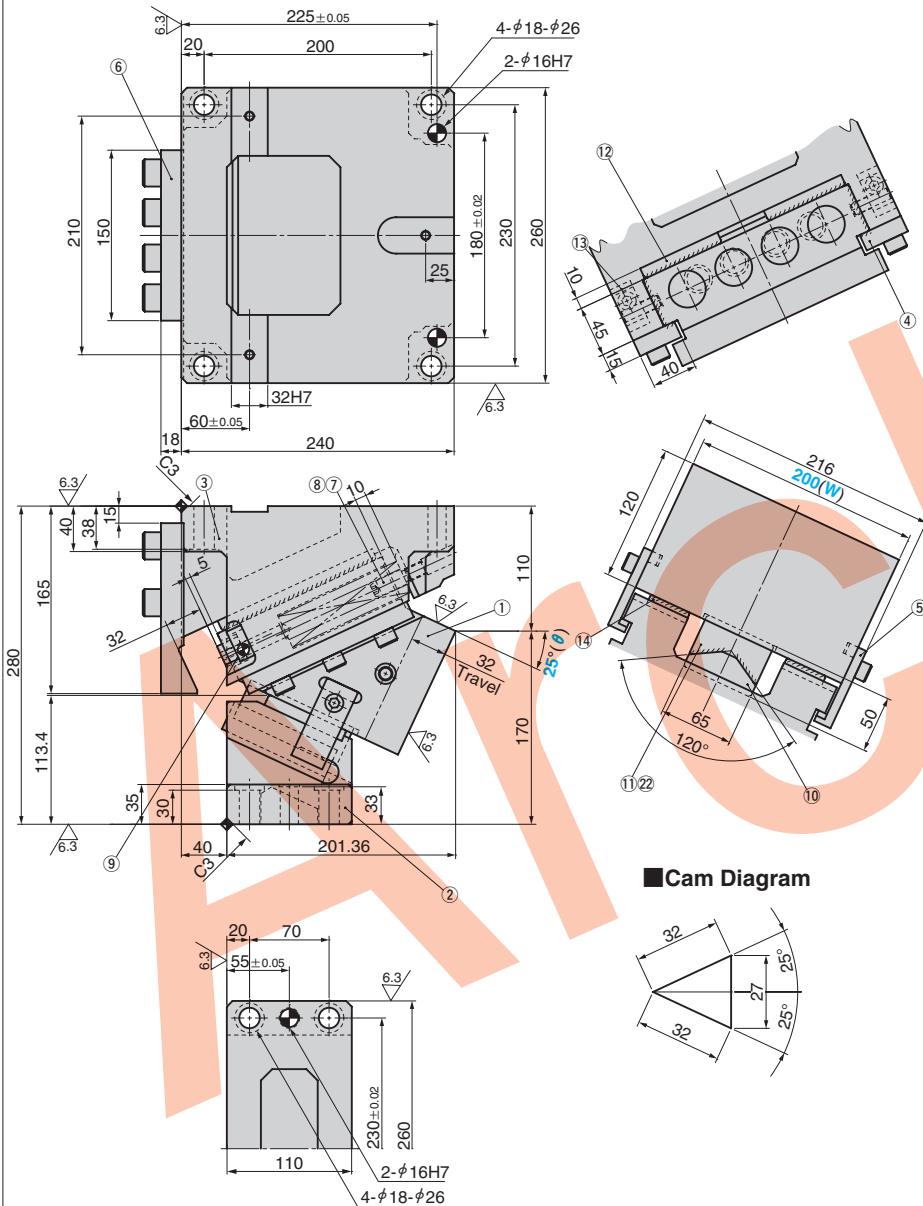

Cam Diagram

Travel S	Working Force kN(tonf)		Spring Force N(kgf)		Return Force N(kgf)	Slider Weight kg	Catalog No.	W	θ
	Standard Working Force (one million strokes)	Allowable Working Force (300,000 strokes)	Initial Load	Final Load					
32.0	93.1 (9.5)	186.2 (19.0)	438.6 (44.7)	5117.0 (521.8)	6860 (700.0)	29.9	UCNBK	200	25



Order

Catalog No. **UCNBK** W **200** - θ **25**



Option

Option Code	Specification
K	Key attached for holder.
KA	Metric key attached for holder.

For key specification, refer to page 737.



Order

UCNBK200-25-K

Refer to page 389 for detailed specifications of tapped holes and dowel pin holes (prepared hole, finish hole) for retainer.

Table of Components

No.	Description	Qty	Material and Remark
①	Cam Slider	1	FC250 with Graphite
②	Cam Driver	1	FC250
③	Cam Holder	1	FC250
④	Upper Plate	2	S45C with Graphite
⑤	Positive Return Follower	2	S45C(1045)
⑥	Stopper Plate	1	S45C(1045)
⑦	Spring Guide Pin	4	SCM435
⑧	Coil Spring	4	TM30×150
⑨	Stopper	4	Urethane
⑩	Cam Bottom Slide Plate	1	S45C(1045)
⑪	Cam Bottom Guide Plate	1	Bronze with Graphite
⑫	Lower Plate	2	Bronze with Graphite
⑬	Plate	2	S45C(1045)
⑭	Driver Plate	2	Bronze with Graphite
⑮	Screw Plug	2	S45C M12

Bolts for assembly are not indicated.

Spring Diagram

- Spring used TM30-150 (4 piece)
- Spring constant 36.55N/mm (3.73kgf/mm)
- Guideline of spring durability 1,000,000 strokes

α : Spring Force at punch retraction of 5 mm
e : Spring return amount when the punch returns 5 mm

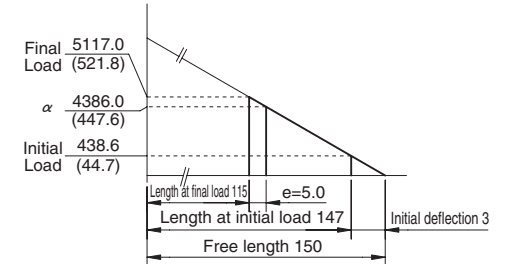

Space for removing

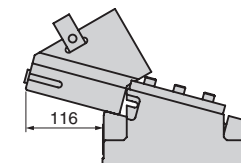

Aerial Cam Unit

FOR PIERCE AND FLANGE

CAD
FILE

UCNBK200-30

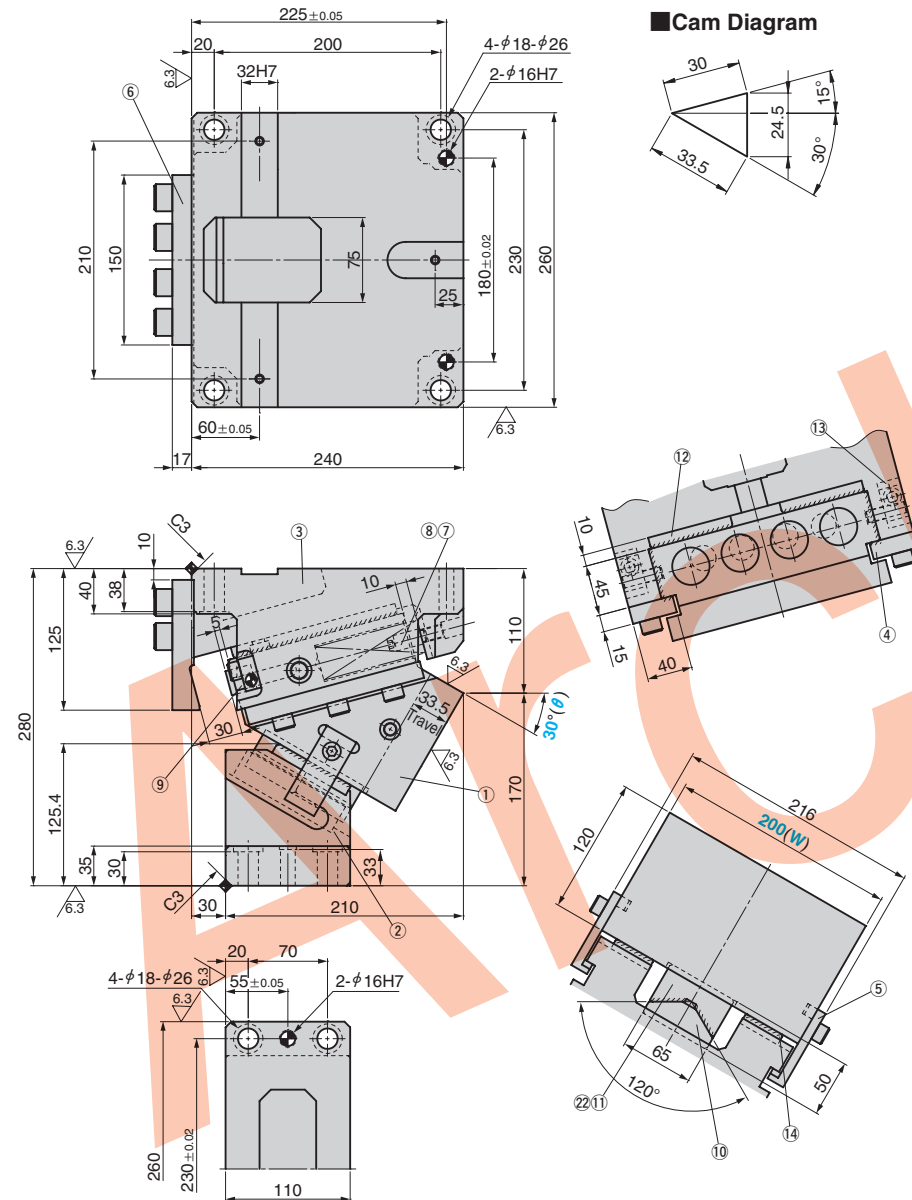

Travel S	Working Force kN(tonf)		Spring Force N(kgf)		Return Force N(kgf)	Slider Weight kg	Catalog No.	W	θ
	Standard Working Force (one million strokes)	Allowable Working Force (300,000 strokes)	Initial Load	Final Load					
33.5	93.1 (9.5)	186.2 (19.0)	350.9 (35.8)	5614.1 (572.5)	6940 (708.2)	29.5	UCNBK	200	30



Order

Catalog No.	W	θ
UCNBK	200	30



Option

Option Code	Specification
K	Key attached for holder.
KA	Metric key attached for holder.

For key specification, refer to page 737.



Order

UCNBK200-30-K

Refer to page 389 for detailed specifications of tapped holes and dowel pin holes (prepared hole, finish hole) for retainer.

Table of Components

No.	Description	Qty	Material and Remark
①	Cam Slider	1	FC250 with Graphite
②	Cam Driver	1	FC250
③	Cam Holder	1	FC250
④	Upper Plate	2	S45C with Graphite
⑤	Positive Return Follower	2	S45C(1045)
⑥	Stopper Plate	1	S45C(1045)
⑦	Spring Guide Pin	4	SCM435
⑧	Coil Spring	4	TM30×125
⑨	Stopper	4	Urethane
⑩	Cam Bottom Slide Plate	1	S45C(1045)
⑪	Cam Bottom Guide Plate	1	Bronze with Graphite
⑫	Lower Plate	2	Bronze with Graphite
⑬	Plate	2	S45C(1045)
⑭	Driver Plate	2	Bronze with Graphite
⑰	Screw Plug	2	S45C M12

Bolts for assembly are not indicated.

Spring Diagram

- Spring used TM30-125 (4 piece)
- Spring constant 43.86N/mm (4.47kgf/mm)
- Guideline of spring durability 1,000,000 strokes

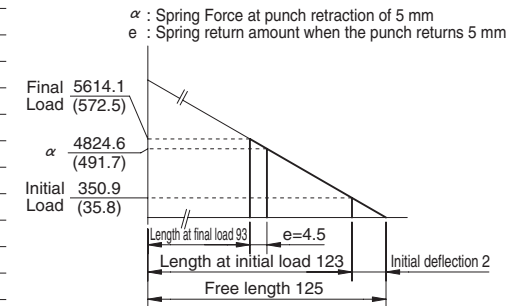

Space for removing

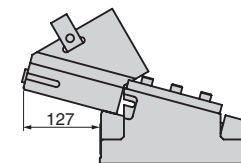

Aerial Cam Unit

FOR PIERCE AND FLANGE

CAD
FILE

UCNBK200-35

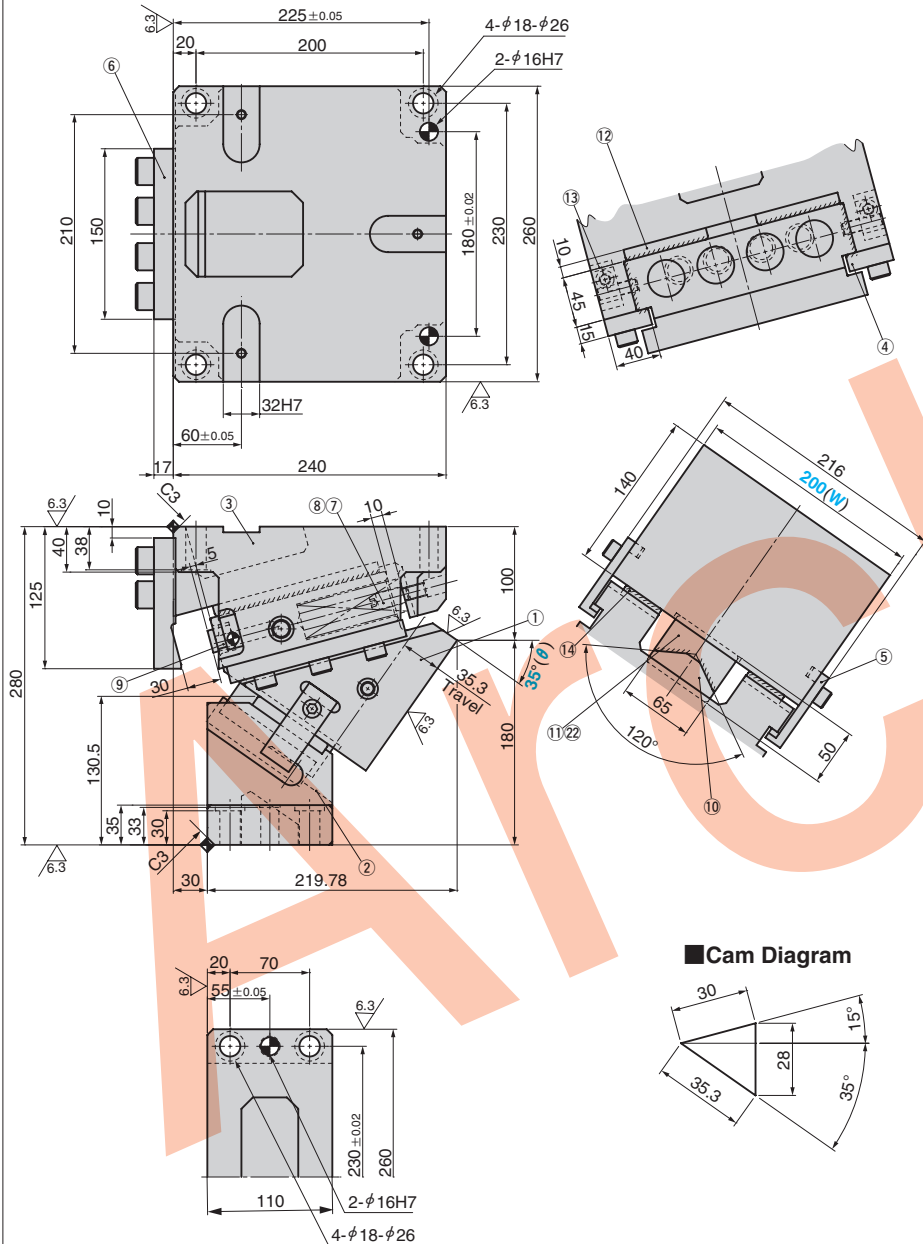

Cam Diagram

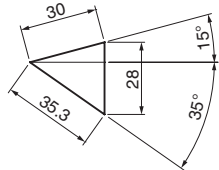

Travel S	Working Force kN(tonf)		Spring Force N(kgf)		Return Force N(kgf)	Slider Weight kg	Catalog No.	W	θ
	Standard Working Force (one million strokes)	Allowable Working Force (300,000 strokes)	Initial Load	Final Load					
35.3	93.1 (9.5)	186.2 (19.0)	350.9 (35.8)	5614.1 (572.5)	7450 (760.2)	30.9	UCNBK	200	35



Order

Catalog No.	W	θ
UCNBK	200	35



Option

Option Code	Specification
K	Key attached for holder.
KA	Metric key attached for holder.

For key specification, refer to page 737.



Order

UCNBK200-35-K

Refer to page 389 for detailed specifications of tapped holes and dowel pin holes (prepared hole, finish hole) for retainer.

Table of Components

No.	Description	Qty	Material and Remark
①	Cam Slider	1	FC250 with Graphite
②	Cam Driver	1	FC250
③	Cam Holder	1	FC250
④	Upper Plate	2	S45C with Graphite
⑤	Positive Return Follower	2	S45C(1045)
⑥	Stopper Plate	1	S45C(1045)
⑦	Spring Guide Pin	4	SCM435
⑧	Coil Spring	4	TM30×125
⑨	Stopper	4	Urethane
⑩	Cam Bottom Slide Plate	1	S45C(1045)
⑪	Cam Bottom Guide Plate	1	Bronze with Graphite
⑫	Lower Plate	2	Bronze with Graphite
⑬	Plate	2	S45C(1045)
⑭	Driver Plate	2	Bronze with Graphite
⑯	Screw Plug	2	S45C M12



Bolts for assembly are not indicated.

Spring Diagram

- Spring used TM30-125 (4 piece)
- Spring constant 43.86N/mm (4.47kgf/mm)
- Guideline of spring durability 1,000,000 strokes

α : Spring Force at punch retraction of 5 mm
e : Spring return amount when the punch returns 5 mm

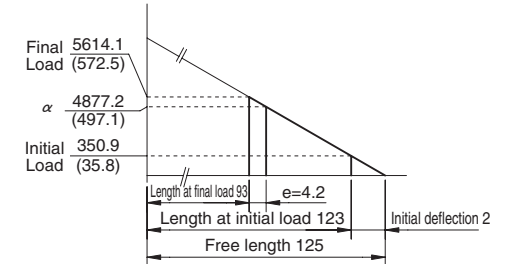

Space for removing

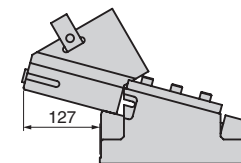

Aerial Cam Unit

FOR PIERCE AND FLANGE

CAD
FILE

UCNBK200-40

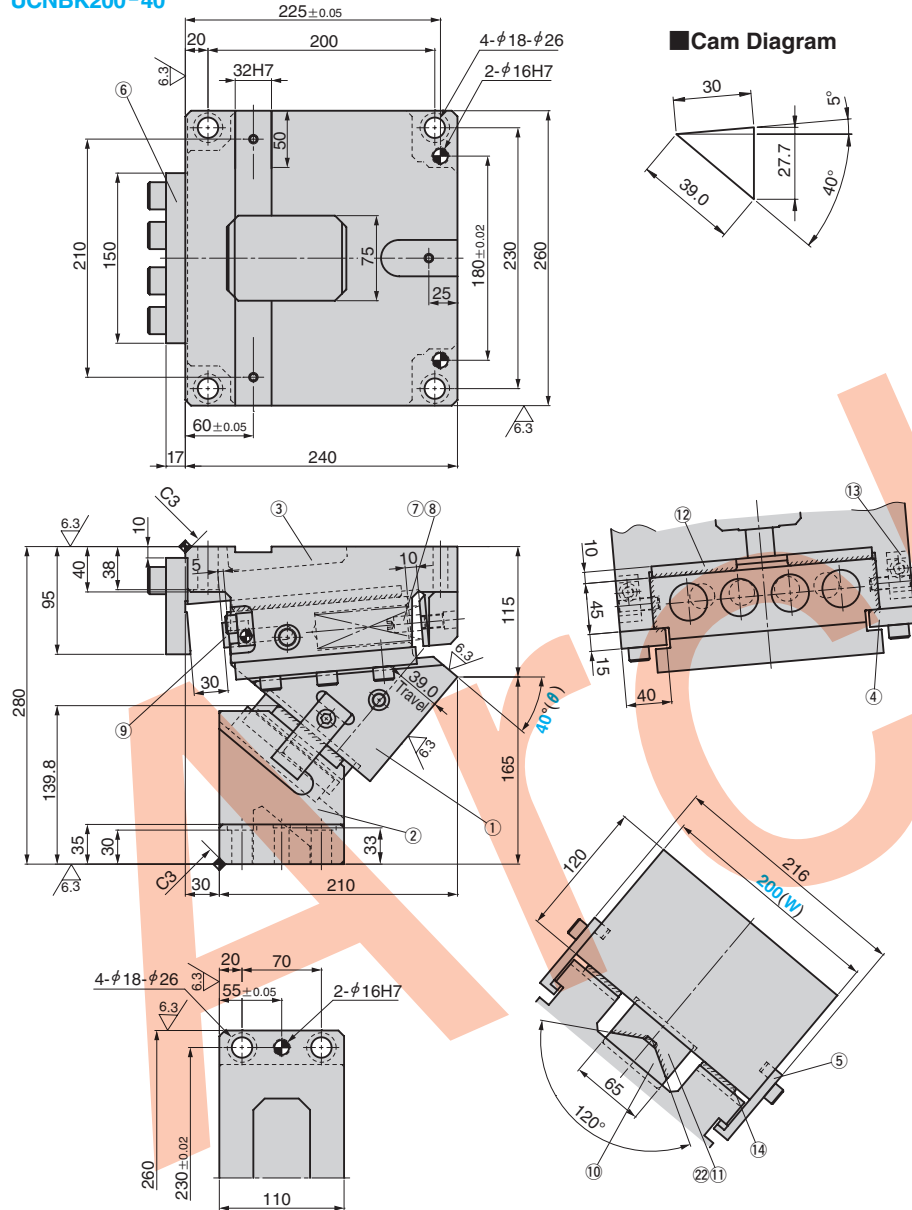

Cam Diagram

Travel S	Working Force kN(tonf)		Spring Force N(kgf)		Return Force N(kgf)	Slider Weight kg	Catalog No.	W	θ
	Standard Working Force (one million strokes)	Allowable Working Force (300,000 strokes)	Initial Load	Final Load					
39.0	93.1 (9.5)	186.2 (19.0)	350.9 (35.8)	5614.1 (572.5)	6877 (701.7)	30.2	UCNBK	200	40



Order

Catalog No. **UCNBK** W **200** - θ **40**



Option

Option Code	Specification
K	Key attached for holder.
KA	Metric key attached for holder.

For key specification, refer to page 737.



Order

UCNBK200-40-K

Refer to page 389 for detailed specifications of tapped holes and dowel pin holes (prepared hole, finish hole) for retainer.

Table of Components

No.	Description	Qty	Material and Remark
①	Cam Slider	1	FC250 with Graphite
②	Cam Driver	1	FC250
③	Cam Holder	1	FC250
④	Upper Plate	2	S45C with Graphite
⑤	Positive Return Follower	2	S45C(1045)
⑥	Stopper Plate	1	S45C(1045)
⑦	Spring Guide Pin	4	SCM435
⑧	Coil Spring	4	TM30×125
⑨	Stopper	4	Urethane
⑩	Cam Bottom Slide Plate	1	S45C(1045)
⑪	Cam Bottom Guide Plate	1	Bronze with Graphite
⑫	Lower Plate	2	Bronze with Graphite
⑬	Plate	2	S45C(1045)
⑭	Driver Plate	2	Bronze with Graphite
⑳	Screw Plug	2	S45C M12

Spring Diagram

- Spring used TM30-125 (4 piece)
- Spring constant 43.86N/mm (4.47kgf/mm)
- Guideline of spring durability 1,000,000 strokes

α : Spring Force at punch retraction of 5 mm
e : Spring return amount when the punch returns 5 mm

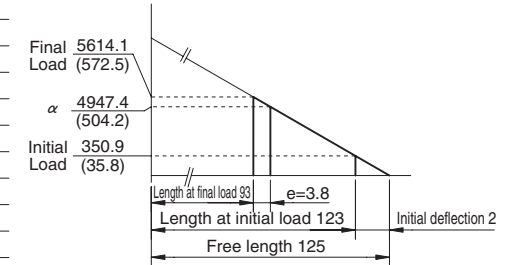

Space for removing

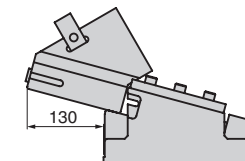

Bolts for assembly are not indicated.

Aerial Cam Unit

FOR PIERCE AND FLANGE

CAD FILE

UCNBK200-45

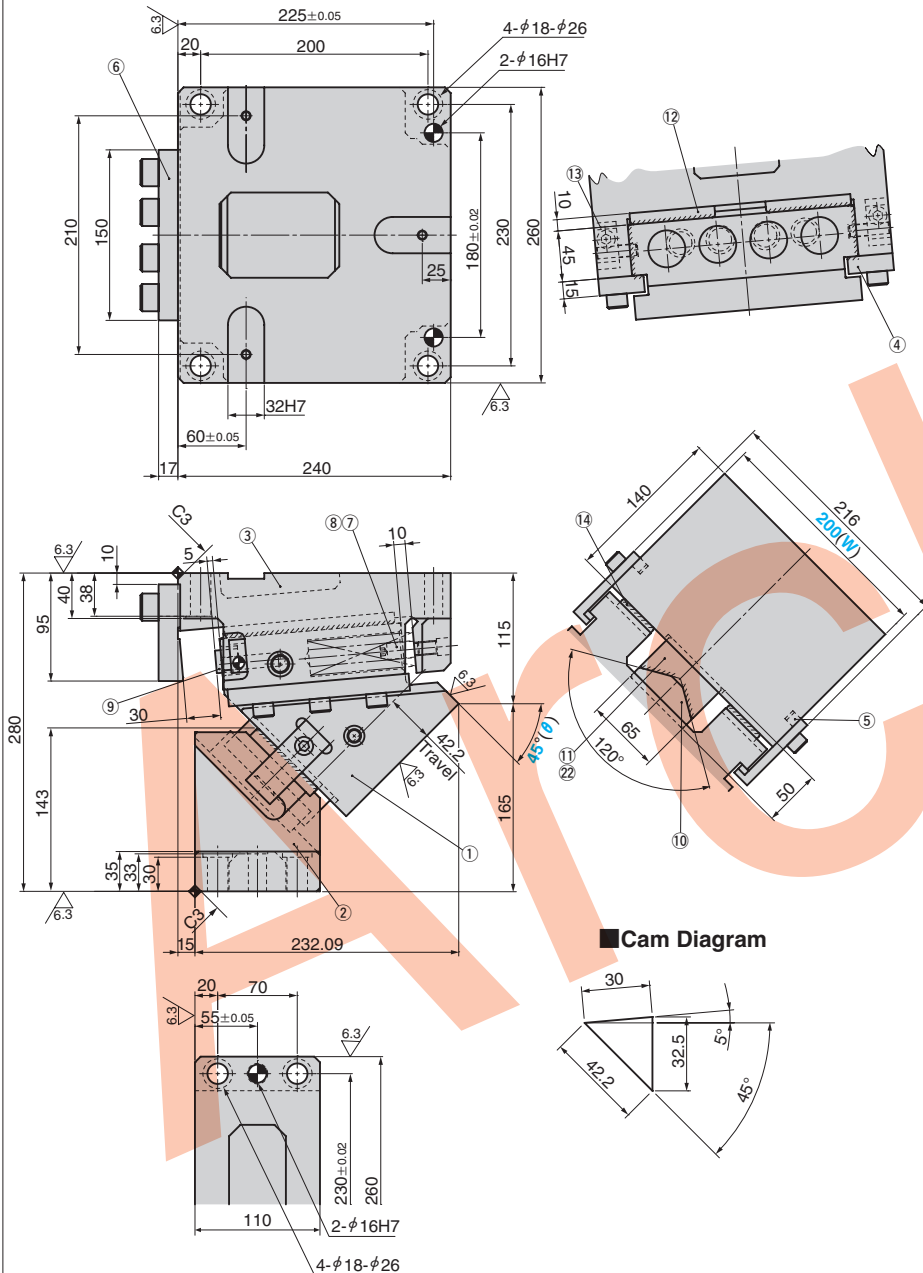

Travel S	Working Force kN(tonf)		Spring Force N(kgf)		Return Force N(kgf)	Slider Weight kg	Catalog No.	W	θ
	Standard Working Force (one million strokes)	Allowable Working Force (300,000 strokes)	Initial Load	Final Load					
42.2	93.1 (9.5)	186.2 (19.0)	350.9 (35.8)	5614.1 (572.5)	7379 (753.0)	31.9	UCNBK	200	45



Order

Catalog No.	W	θ
UCNBK	200	45



Option

Option Code	Specification
K	Key attached for holder.
KA	Metric key attached for holder.

For key specification, refer to page 737.



Order

UCNBK200-45-K

Refer to page 389 for detailed specifications of tapped holes and dowel pin holes (prepared hole, finish hole) for retainer.

Table of Components

No.	Description	Qty	Material and Remark
①	Cam Slider	1	FC250 with Graphite
②	Cam Driver	1	FC250
③	Cam Holder	1	FC250
④	Upper Plate	2	S45C with Graphite
⑤	Positive Return Follower	2	S45C(1045)
⑥	Stopper Plate	1	S45C(1045)
⑦	Spring Guide Pin	4	SCM435
⑧	Coil Spring	4	TM30×125
⑨	Stopper	4	Urethane
⑩	Cam Bottom Slide Plate	1	S45C(1045)
⑪	Cam Bottom Guide Plate	1	Bronze with Graphite
⑫	Lower Plate	2	Bronze with Graphite
⑬	Plate	2	S45C(1045)
⑭	Driver Plate	2	Bronze with Graphite
⑮	Screw Plug	2	S45C M12

Bolts for assembly are not indicated.

Spring Diagram

- Spring used TM30-125 (4 piece)
- Spring constant 43.86N/mm (4.47kgf/mm)
- Guideline of spring durability 1,000,000 strokes

α : Spring Force at punch retraction of 5 mm
e : Spring return amount when the punch returns 5 mm

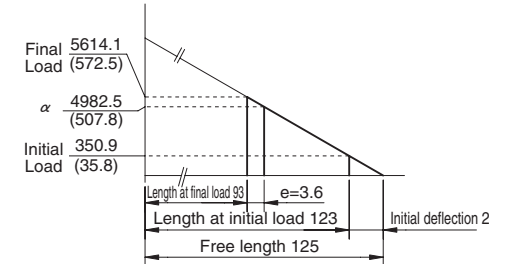

Space for removing

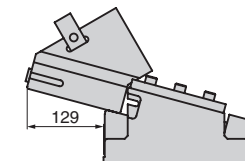

Aerial Cam Unit

FOR PIERCE AND FLANGE

CAD
FILE

UCNBK200-50

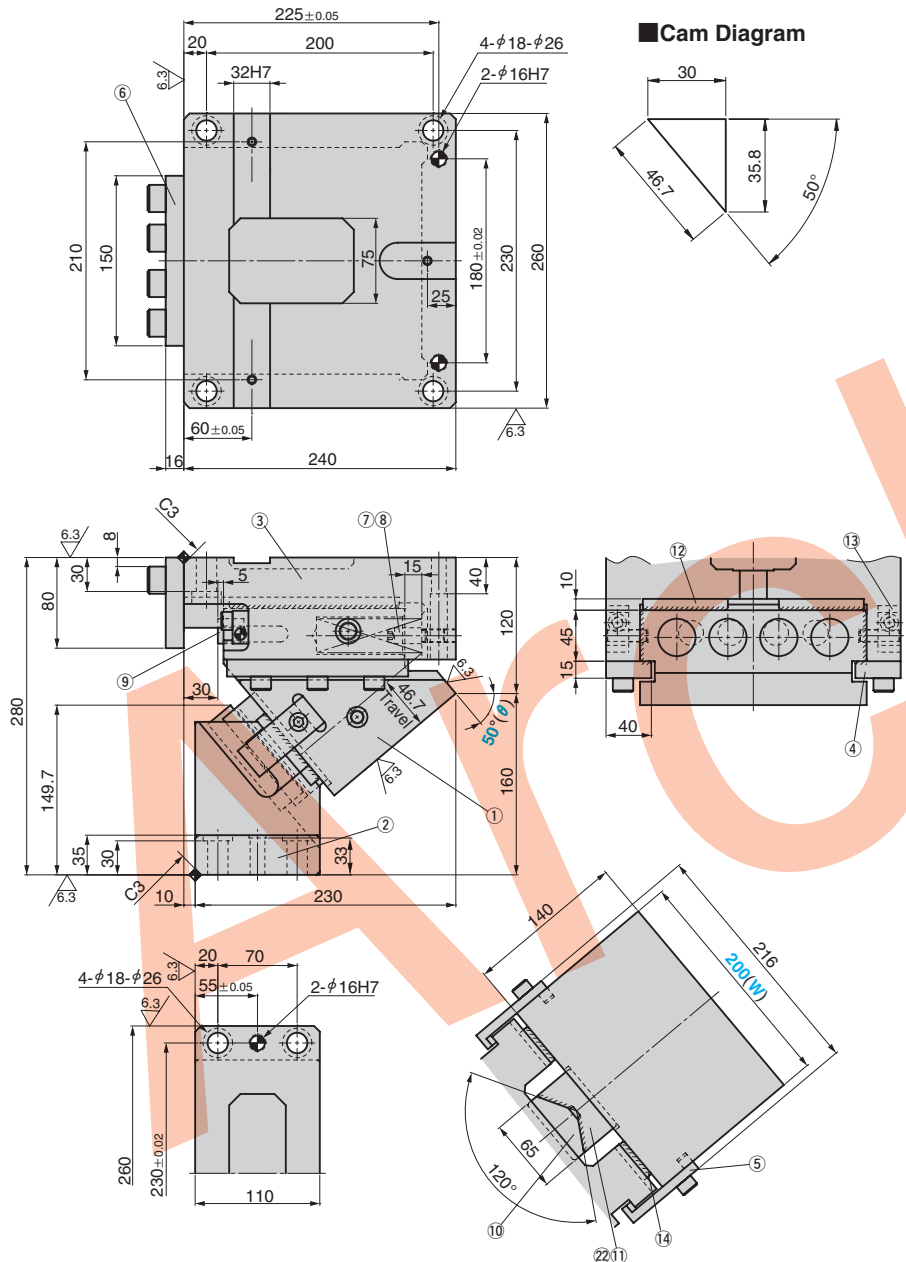

Travel S	Working Force kN(tonf)		Spring Force N(kgf)		Return Force N(kgf)	Slider Weight kg	Catalog No.	W	θ
	Standard Working Force (one million strokes)	Allowable Working Force (300,000 strokes)	Initial Load	Final Load					
46.7	93.1 (9.5)	186.2 (19.0)	350.9 (35.8)	5614.1 (572.5)	7342 (749.2)	32.4	UCNBK	200	50



Order

Catalog No.	W	θ
UCNBK	200	50



Option

Option Code	Specification
K	Key attached for holder.
KA	Metric key attached for holder.

For key specification, refer to page 737.



Order

UCNBK200-50-K

Refer to page 389 for detailed specifications of tapped holes and dowel pin holes (prepared hole, finish hole) for retainer.

Table of Components

No.	Description	Qty	Material and Remark
①	Cam Slider	1	FC250 with Graphite
②	Cam Driver	1	FC250
③	Cam Holder	1	FC250
④	Upper Plate	2	S45C with Graphite
⑤	Positive Return Follower	2	S45C(1045)
⑥	Stopper Plate	1	S45C(1045)
⑦	Spring Guide Pin	4	SCM435
⑧	Coil Spring	4	TM30×125
⑨	Stopper	4	Urethane
⑩	Cam Bottom Slide Plate	1	S45C(1045)
⑪	Cam Bottom Guide Plate	1	Bronze with Graphite
⑫	Lower Plate	2	Bronze with Graphite
⑬	Plate	2	S45C(1045)
⑭	Driver Plate	2	Bronze with Graphite
⑵	Screw Plug	2	S45C M12

Bolts for assembly are not indicated.

Spring Diagram

- Spring used TM30-125 (4 piece)
- Spring constant 43.86N/mm (4.47kgf/mm)
- Guideline of spring durability 1,000,000 strokes

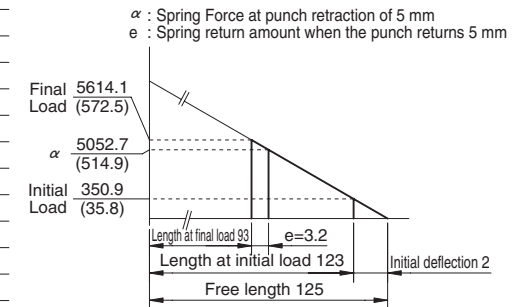

Space for removing

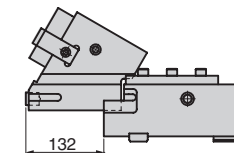

Aerial Cam Unit

FOR PIERCE AND FLANGE

CAD FILE

UCNBK200-55

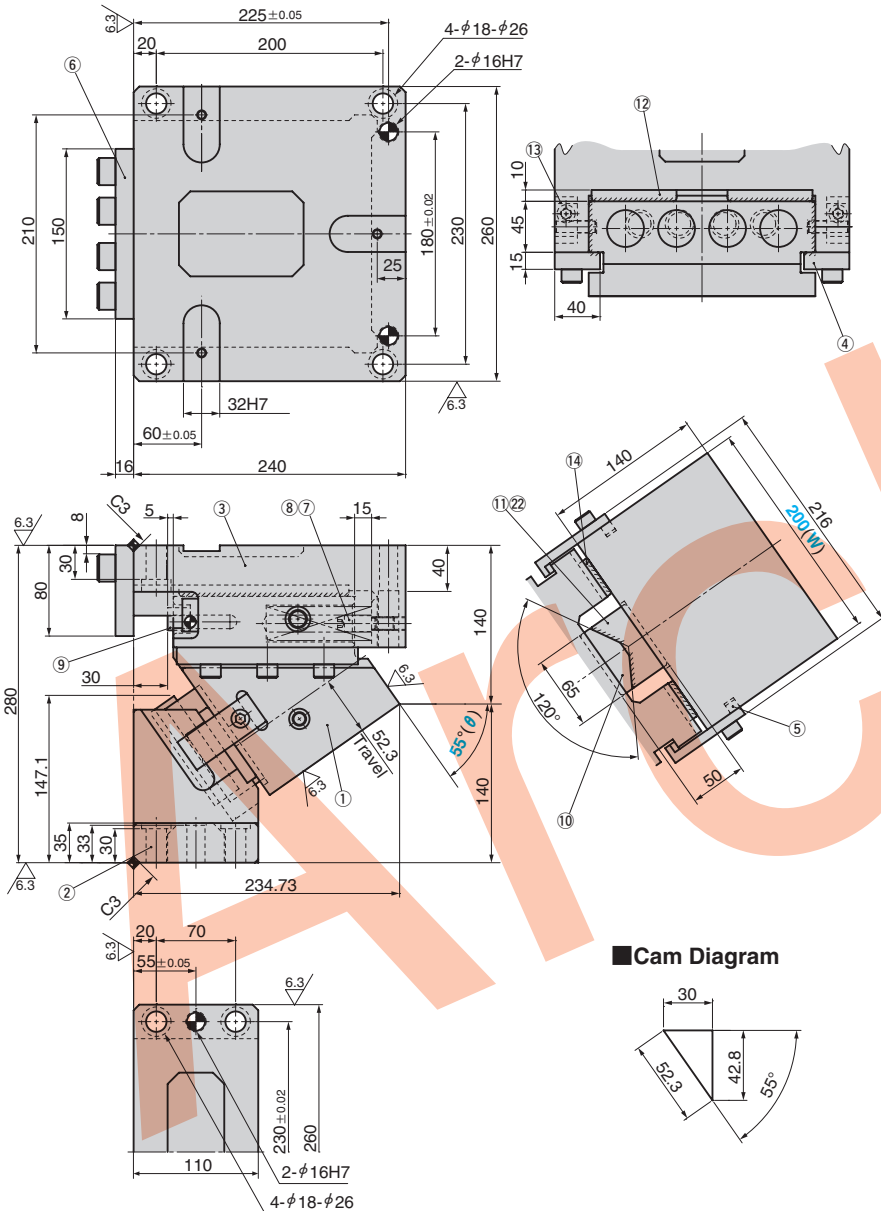

Travel S	Working Force kN(tonf)		Spring Force N(kgf)		Return Force N(kgf)	Slider Weight kg	Catalog No.	W	θ
	Standard Working Force (one million strokes)	Allowable Working Force (300,000 strokes)	Initial Load	Final Load					
52.3	93.1 (9.5)	186.2 (19.0)	350.9 (35.8)	5614.1 (572.5)	7989 (815.2)	31.9	UCNBK	200	55



Order

Catalog No. **UCNBK** W **200** - θ **55**



Option

Option Code	Specification
K	Key attached for holder.
KA	Metric key attached for holder.

For key specification, refer to page 737.



Order

UCNBK200-55-K

Refer to page 389 for detailed specifications of tapped holes and dowel pin holes (prepared hole, finish hole) for retainer.

Table of Components

No.	Description	Qty	Material and Remark
①	Cam Slider	1	FC250 with Graphite
②	Cam Driver	1	FC250
③	Cam Holder	1	FC250
④	Upper Plate	2	S45C with Graphite
⑤	Positive Return Follower	2	S45C(1045)
⑥	Stopper Plate	1	S45C(1045)
⑦	Spring Guide Pin	4	SCM435
⑧	Coil Spring	4	TM30×125
⑨	Stopper	4	Urethane
⑩	Cam Bottom Slide Plate	1	S45C(1045)
⑪	Cam Bottom Guide Plate	1	Bronze with Graphite
⑫	Lower Plate	2	Bronze with Graphite
⑬	Plate	2	S45C(1045)
⑭	Driver Plate	2	Bronze with Graphite
⑮	Screw Plug	2	S45C M12



Bolts for assembly are not indicated.

Spring Diagram

- Spring used TM30-125 (4 piece)
- Spring constant 43.86N/mm (4.47kgf/mm)
- Guideline of spring durability 1,000,000 strokes

α : Spring Force at punch retraction of 5 mm
e : Spring return amount when the punch returns 5 mm

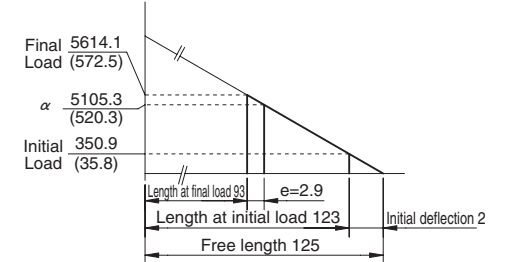

Space for removing

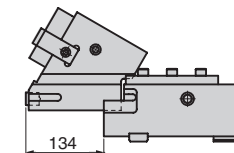

Aerial Cam Unit

FOR PIERCE AND FLANGE

CAD
FILE

UCNBK200-60

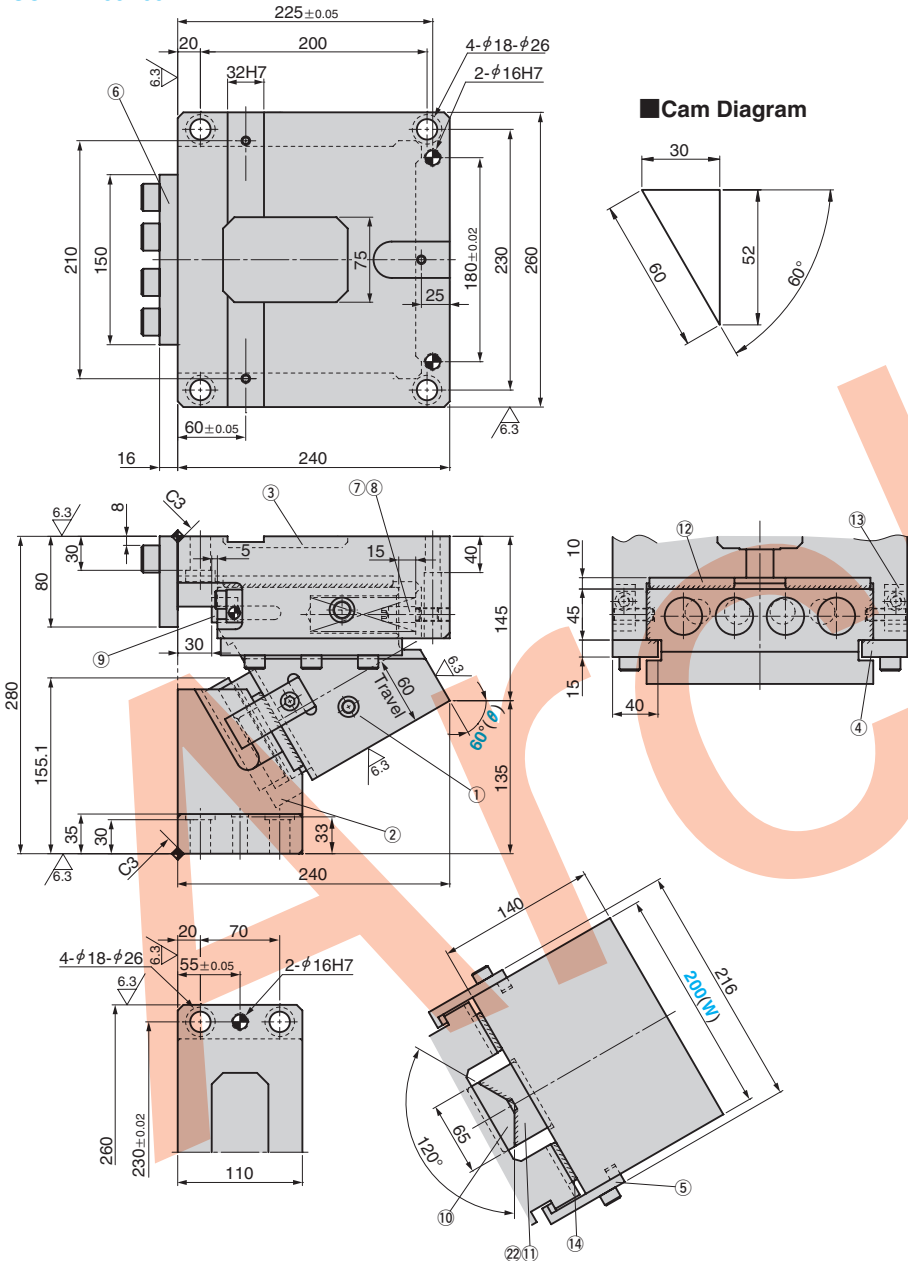

Cam Diagram

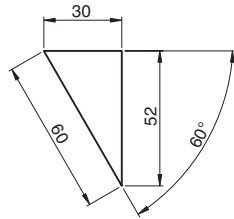

Travel S	Working Force kN(tonf)		Spring Force N(kgf)		Return Force N(kgf)	Slider Weight kg	Catalog No.	W	θ
	Standard Working Force (one million strokes)	Allowable Working Force (300,000 strokes)	Initial Load	Final Load					
60.0	93.1 (9.5)	186.2 (19.0)	350.9 (35.8)	5614.1 (572.5)	8829 (900.9)	33.5	UCNBK	200	60



Order

Catalog No.	W	θ
UCNBK	200	60



Option

Option Code	Specification
K	Key attached for holder.
KA	Metric key attached for holder.

For key specification, refer to page 737.



Order

UCNBK200-60-K

Refer to page 389 for detailed specifications of tapped holes and dowel pin holes (prepared hole, finish hole) for retainer.

Table of Components

No.	Description	Qty	Material and Remark
①	Cam Slider	1	FC250 with Graphite
②	Cam Driver	1	FC250
③	Cam Holder	1	FC250
④	Upper Plate	2	S45C with Graphite
⑤	Positive Return Follower	2	S45C(1045)
⑥	Stopper Plate	1	S45C(1045)
⑦	Spring Guide Pin	4	SCM435
⑧	Coil Spring	4	TM30×125
⑨	Stopper	4	Urethane
⑩	Cam Bottom Slide Plate	1	S45C(1045)
⑪	Cam Bottom Guide Plate	1	Bronze with Graphite
⑫	Lower Plate	2	Bronze with Graphite
⑬	Plate	2	S45C(1045)
⑭	Driver Plate	2	Bronze with Graphite
⑯	Screw Plug	2	S45C M12



Bolts for assembly are not indicated.

Spring Diagram

- Spring used TM30-125 (4 piece)
- Spring constant 43.86N/mm (4.47kgf/mm)
- Guideline of spring durability 1,000,000 strokes

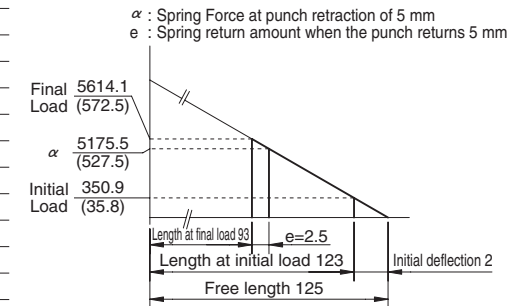

Space for removing

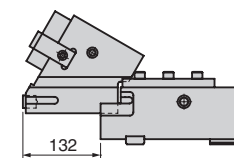

Aerial Cam Unit

FOR PIERCE AND FLANGE

CAD
FILE

UCNBK200-65

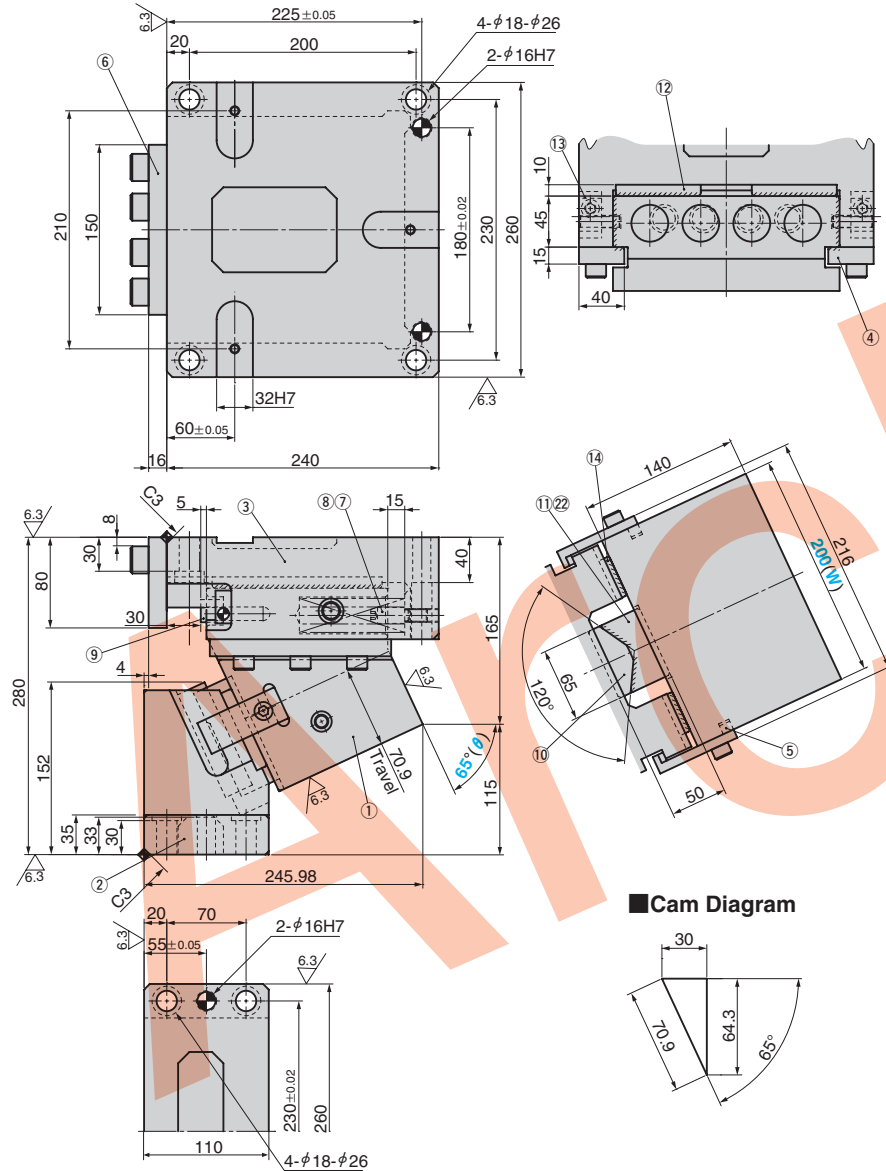

Cam Diagram

Travel S	Working Force kN(tonf)		Spring Force N(kgf)		Return Force N(kgf)	Slider Weight kg	Catalog No.	W	θ
	Standard Working Force (one million strokes)	Allowable Working Force (300,000 strokes)	Initial Load	Final Load					
70.9	93.1 (9.5)	186.2 (19.0)	350.9 (35.8)	5614.1 (572.5)	9961 (1016.4)	31.9	UCNBK	200	65

Order **Catalog No.** **W** - **θ**
UCNBK **200** - **65**

Option **Option Code** **Specification**

K	Key attached for holder.
KA	Metric key attached for holder.

For key specification, refer to page 737.

Order **UCNBK200-65-K**

Refer to page 389 for detailed specifications of tapped holes and dowel pin holes (prepared hole, finish hole) for retainer.

Table of Components

No.	Description	Qty	Material and Remark
①	Cam Slider	1	FC250 with Graphite
②	Cam Driver	1	FC250
③	Cam Holder	1	FC250
④	Upper Plate	2	S45C with Graphite
⑤	Positive Return Follower	2	S45C(1045)
⑥	Stopper Plate	1	S45C(1045)
⑦	Spring Guide Pin	4	SCM435
⑧	Coil Spring	4	TM30×125
⑨	Stopper	4	Urethane
⑩	Cam Bottom Slide Plate	1	S45C(1045)
⑪	Cam Bottom Guide Plate	1	Bronze with Graphite
⑫	Lower Plate	2	Bronze with Graphite
⑬	Plate	2	S45C(1045)
⑭	Driver Plate	2	Bronze with Graphite
⑰	Screw Plug	2	S45C M12

Bolts for assembly are not indicated.

Spring Diagram

- Spring used TM30-125 (4 piece)
- Spring constant 43.86N/mm (4.47kgf/mm)
- Guideline of spring durability 1,000,000 strokes

α : Spring Force at punch retraction of 5 mm
 e : Spring return amount when the punch returns 5 mm

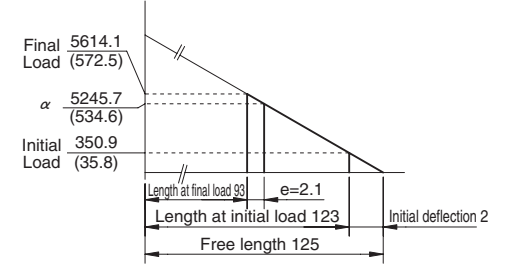

Space for removing

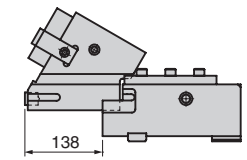

Aerial Cam Unit

FOR PIERCE AND FLANGE

CAD FILE

UCNBK200-70

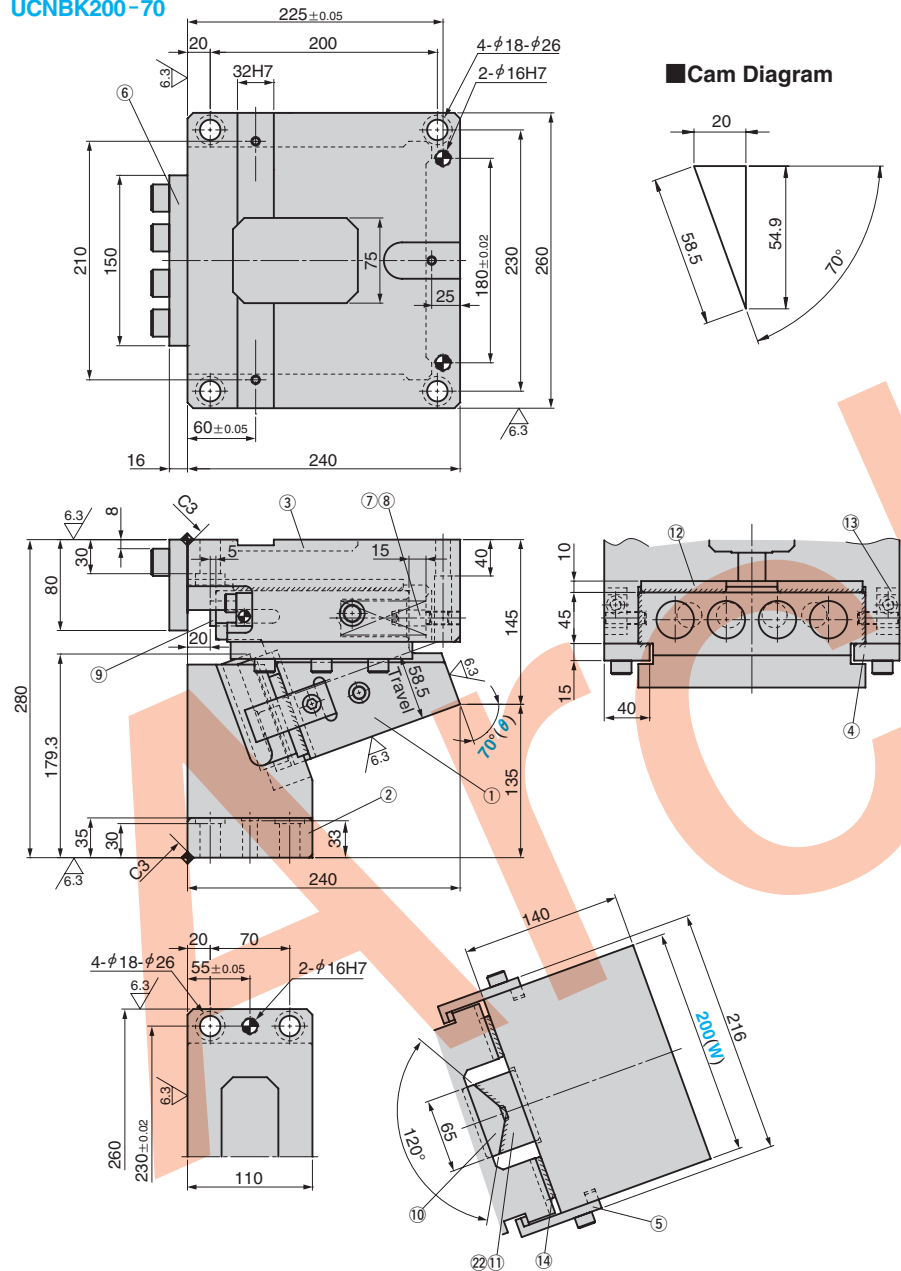

Travel S	Working Force kN(tonf)		Spring Force N(kgf)		Return Force N(kgf)	Slider Weight kg	Catalog No.	W	θ
	Standard Working Force (one million strokes)	Allowable Working Force (300,000 strokes)	Initial Load	Final Load					
58.5	93.1 (9.5)	186.2 (19.0)	1096.6 (111.8)	5483.0 (559.1)	11253 (1148.2)	30.2	UCNBK	200	70



Order

Catalog No.	W	θ
UCNBK	200	70



Option

Option Code	Specification
K	Key attached for holder.
KA	Metric key attached for holder.

For key specification, refer to page 737.



Order

UCNBK200-70-K

Refer to page 389 for detailed specifications of tapped holes and dowel pin holes (prepared hole, finish hole) for retainer.

Table of Components

No.	Description	Qty	Material and Remark
①	Cam Slider	1	FC250 with Graphite
②	Cam Driver	1	FC250
③	Cam Holder	1	FC250
④	Upper Plate	2	S45C with Graphite
⑤	Positive Return Follower	2	S45C(1045)
⑥	Stopper Plate	1	S45C(1045)
⑦	Spring Guide Pin	4	SCM435
⑧	Coil Spring	4	TM30×100
⑨	Stopper	4	Urethane
⑩	Cam Bottom Slide Plate	1	S45C(1045)
⑪	Cam Bottom Guide Plate	1	Bronze with Graphite
⑫	Lower Plate	2	Bronze with Graphite
⑬	Plate	2	S45C(1045)
⑭	Driver Plate	2	Bronze with Graphite
⑯	Screw Plug	2	S45C M12

Bolts for assembly are not indicated.

Spring Diagram

- Spring used TM30-100 (4 piece)
- Spring constant 54.83N/mm (5.59kgf/mm)
- Guideline of spring durability 1,000,000 strokes

α : Spring Force at punch retraction of 5 mm
e : Spring return amount when the punch returns 5 mm

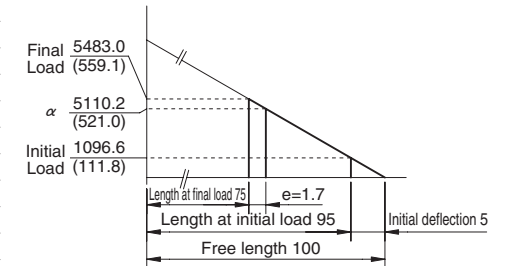

Space for removing

