

For Pierce and Flange

Aerial Cam Unit General Description of UCNBK

OUTLINE OF UCNBK

- High rigidity because of the box structure to keep the slider.
- V-shaped guide.
- 65, 100 and 200mm are available for the mounting width.
- Available angle is 0° to 70° at increments of 5°.

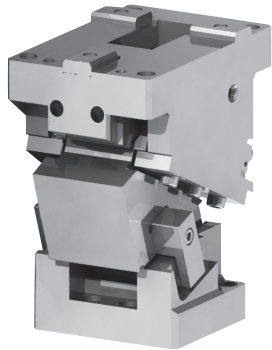

Option of UCNBK

Key Specification (-K)

UCNBK65

LKU25-100 (with 2-M8 bolts)

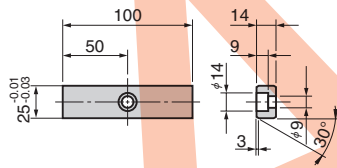

UCNBK100/200

LKU32-50 (with 3-M8 bolts)

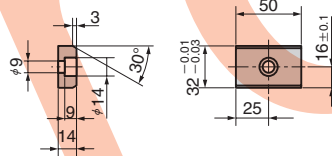

Metric Key Specification (-KA)

UCNBK100/200

LKE25-32-50 (with 3-M8 bolts)

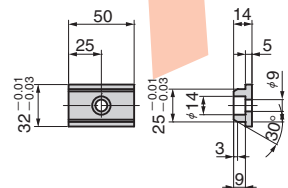

UCNBK Structure and Assembly / Disassembly

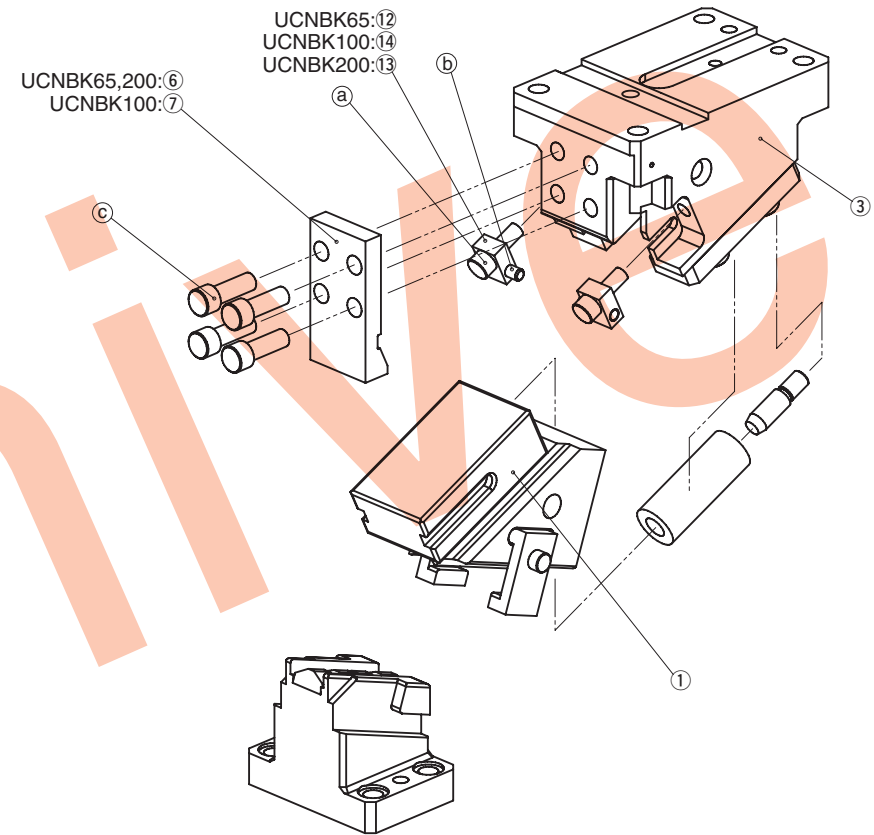

Disassembly method of UCNBK

- 1) Loosen hexagon socket head bolt (a) and remove plate (UCNBK65:12 UCNBK100:14 UCNBK200:13) and dowel pin (b).
- 2) Loosen hexagon socket head bolt (c) and remove stopper plate (UCNBK65,200:6 UCNBK100:7).
- 3) Pull and remove cam slider (1) from cam holder (3) to the rear.

Assembly method of UCNBK

- 1) Assemble components in the reverse order of disassembly.
 - Make sure that there is no foreign matter on the sliding area and assemble components.
 - The clearance between the cam slider and the cam holder is controlled. Match the stamped serial number on the holder and slider before assembly.
 - When cam is disassembled and then reassembled, please do not forget to assemble all bolts provided.

Aerial Cam Unit

FOR PIERCE AND FLANGE

CAD FILE

UCNBK65 - 00

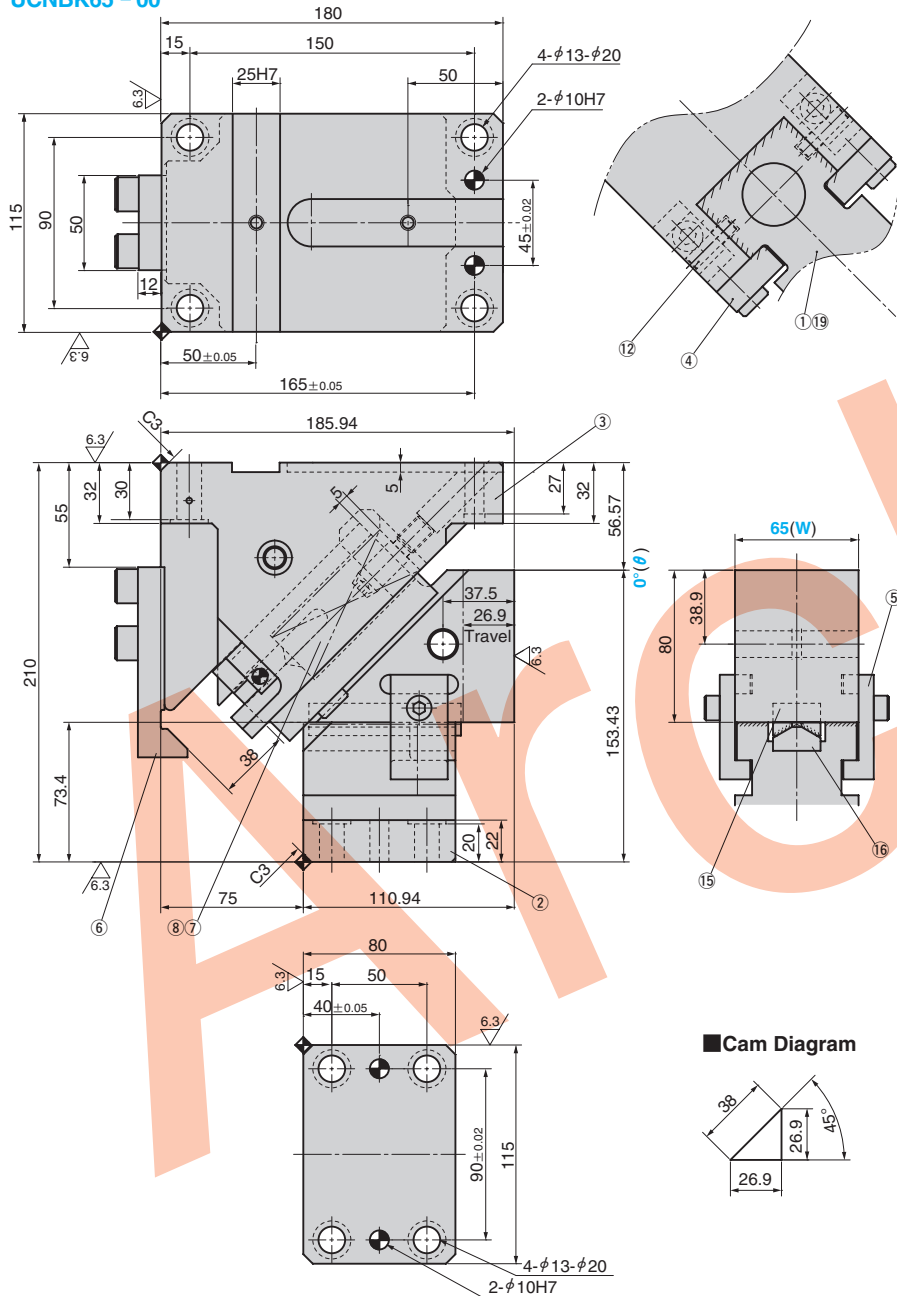

Travel S	Working Force kN(tonf)		Spring Force N(kgf)		Return Force N(kgf)	Catalog No.	W	θ
	Standard Working Force (one million strokes)	Allowable Working Force (300,000 strokes)	Initial Load	Final Load				
26.9	19.6 (2.0)	39.2 (4.0)	166.3 (17.0)	1069.2 (109.0)	1349 (137.6)	UCNBK	65	00



Order

Catalog No.	W	θ
UCNBK	65	00



Option

Option Code	Specification
K	Key attached for holder.

For key specification, refer to page 737.



Order

UCNBK65 - 00 - K

Refer to page 389 for detailed specifications of tapped holes and dowel pin holes (prepared hole, finish hole) for retainer.

Table of Components

No.	Description	Qty	Material and Remark
①	Cam Slider	1	FC250 with Graphite
②	Cam Driver	1	FC250 with Graphite
③	Cam Holder	1	FC250
④	Upper Plate	2	FC250 with Graphite
⑤	Positive Return Follower	2	S45C(1045)
⑥	Stopper Plate	1	S45C(1045)
⑦	Spring Guide Pin	1	φ14×50
⑧	Coil Spring	1	TL30-125
⑫	Plate	2	S45C(1045)
⑮	Cam Bottom Guide Plate	1	Bronze with Graphite
⑯	Cam Bottom Slide Plate	1	S45C(1045)
⑰	Stopper	2	Urethane

Spring Diagram

- Spring used TL30-125 (1 piece)
 - Spring constant 23.76N/mm (2.42kgf/mm)
 - Guideline of spring durability 500,000 strokes
- α : Spring Force at punch retraction of 5 mm
e : Spring return amount when the punch returns 5 mm

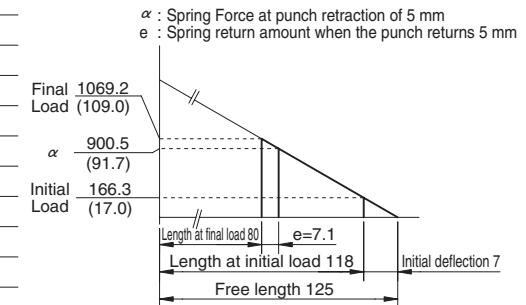

Bolts for assembly are not indicated.

Space for removing

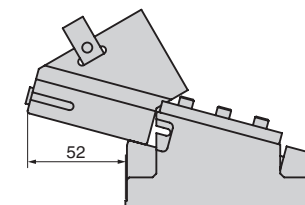

Aerial Cam Unit

FOR PIERCE AND FLANGE

CAD FILE

UCNBK65 - 05

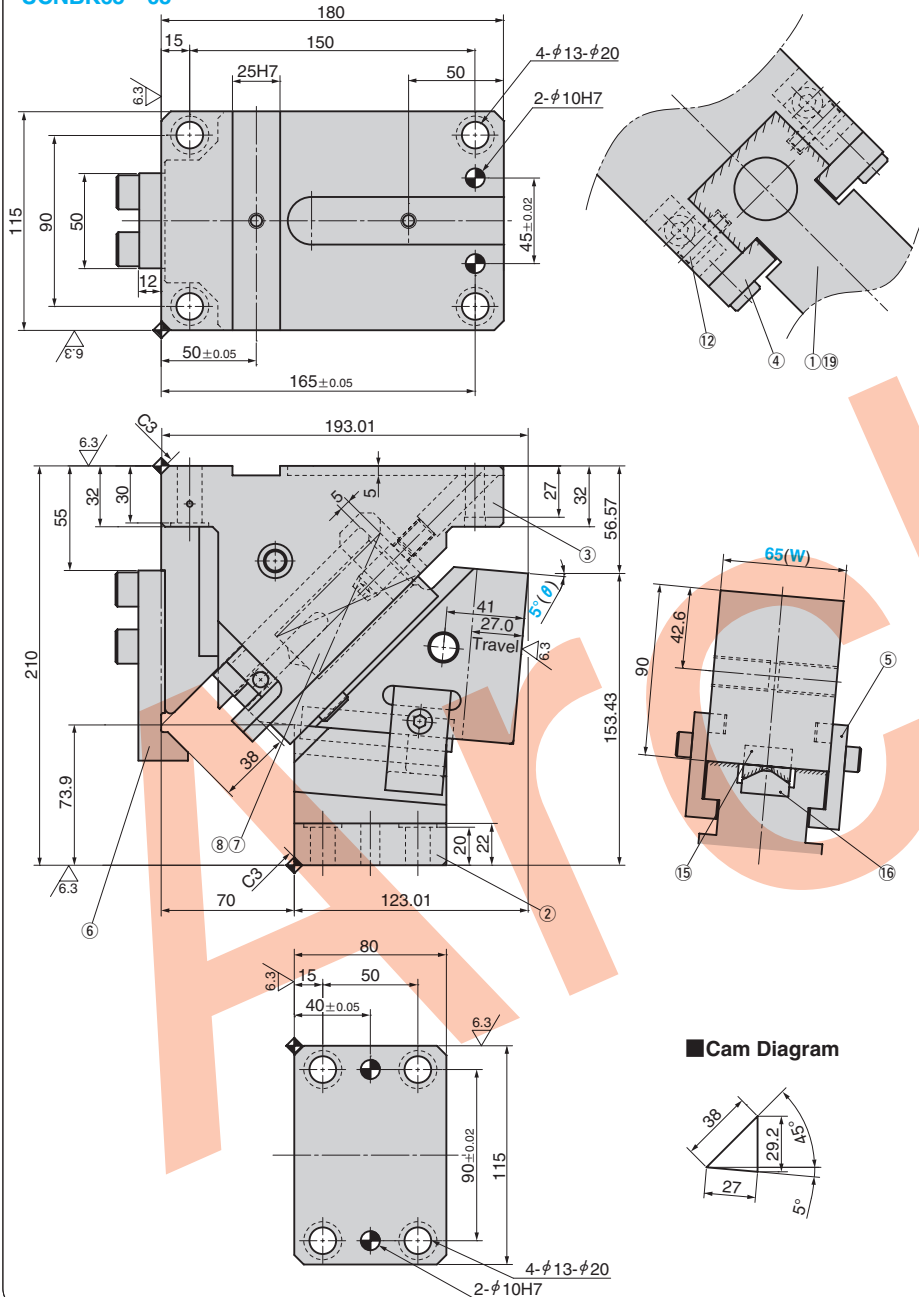

Travel S	Working Force kN(tonf)		Spring Force N(kgf)		Return Force N(kgf)	Catalog No.	W	θ
	Standard Working Force (one million strokes)	Allowable Working Force (300,000 strokes)	Initial Load	Final Load				
27.0	19.6 (2.0)	39.2 (4.0)	237.6 (24.2)	1140.5 (116.3)	1544 (157.6)	UCNBK	65	05



Order

Catalog No.	W	θ
UCNBK	65	05



Option

Option Code	Specification
K	Key attached for holder.

For key specification, refer to page 737.



Order

UCNBK65 - 05 - K

Refer to page 389 for detailed specifications of tapped holes and dowel pin holes (prepared hole, finish hole) for retainer.

Table of Components

No.	Description	Qty	Material and Remark
①	Cam Slider	1	FC250 with Graphite
②	Cam Driver	1	FC250 with Graphite
③	Cam Holder	1	FC250
④	Upper Plate	2	FC250 with Graphite
⑤	Positive Return Follower	2	S45C(1045)
⑥	Stopper Plate	1	S45C(1045)
⑦	Spring Guide Pin	1	φ 14×50
⑧	Coil Spring	1	TL30-125
⑫	Plate	2	S45C(1045)
⑮	Cam Bottom Guide Plate	1	Bronze with Graphite
⑯	Cam Bottom Slide Plate	1	S45C(1045)
⑲	Stopper	2	Urethane

Bolts for assembly are not indicated.

Spring Diagram

- Spring used TL30-125 (1 piece)
- Spring constant 23.76N/mm (2.42kgf/mm)
- Guideline of spring durability 300,000 strokes

α : Spring Force at punch retraction of 5 mm
e : Spring return amount when the punch returns 5 mm

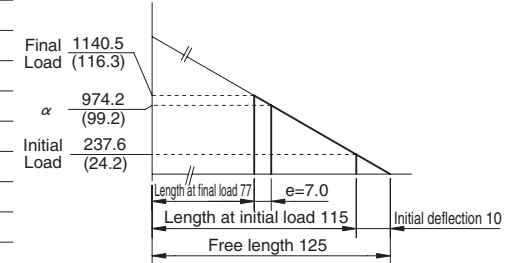

Space for removing

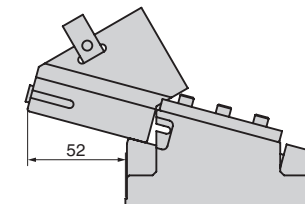

Aerial Cam Unit

FOR PIERCE AND FLANGE

CAD FILE

UCNBK65 - 10

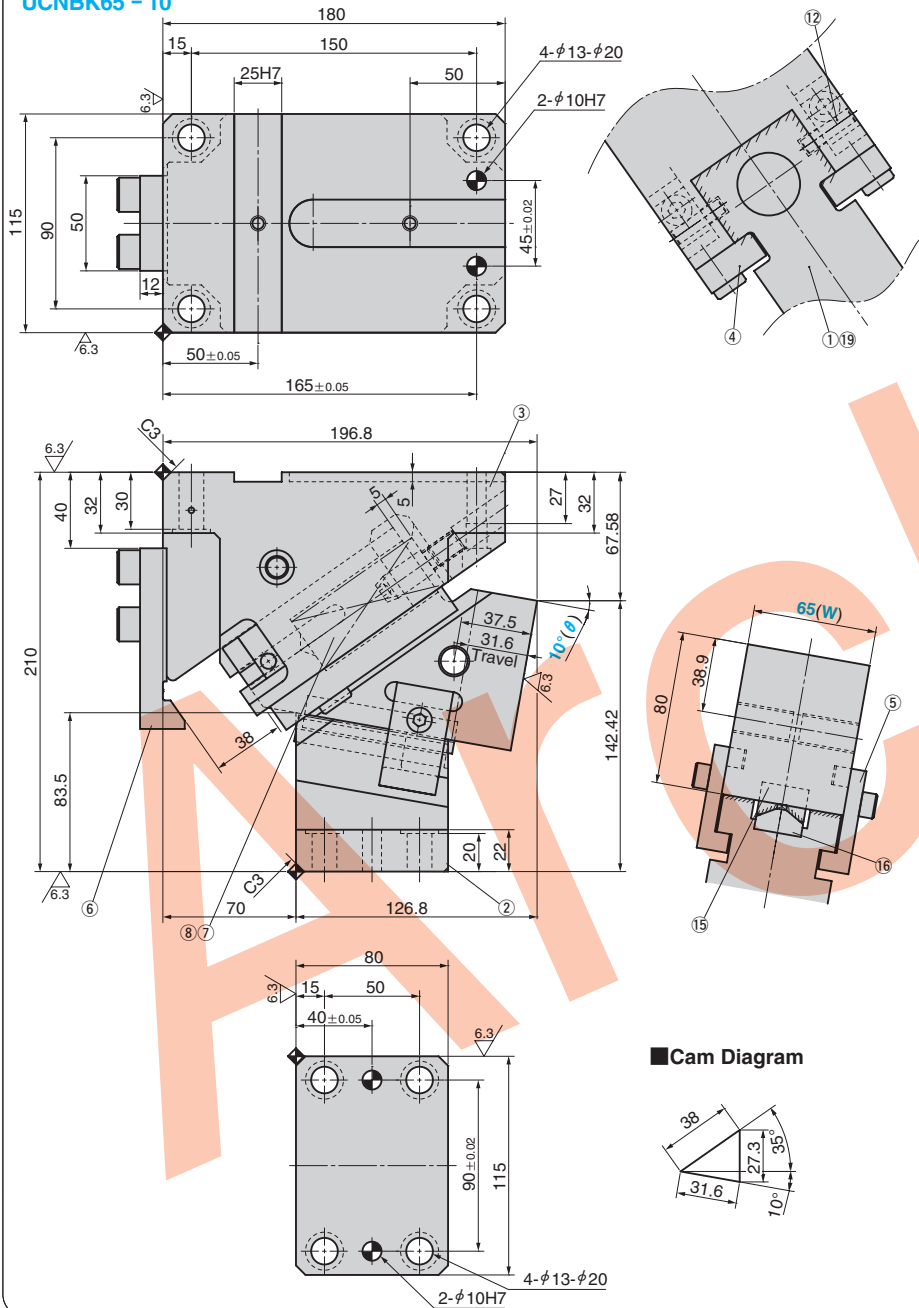

Cam Diagram

Travel S	Working Force kN(tonf)		Spring Force N(kgf)		Return Force N(kgf)	Catalog No.	W	θ
	Standard Working Force (one million strokes)	Allowable Working Force (300,000 strokes)	Initial Load	Final Load				
31.6	19.6 (2.0)	39.2 (4.0)	237.6 (24.2)	1140.5 (116.3)	1427 (145.6)	UCNBK	65	10



Order **Catalog No.** W - θ
UCNBK 65 - 10



Option Code	Specification
K	Key attached for holder.

For key specification, refer to page 737.



Order **UCNBK65 - 10 - K**

Refer to page 389 for detailed specifications of tapped holes and dowel pin holes (prepared hole, finish hole) for retainer.

Table of Components

No.	Description	Qty	Material and Remark
①	Cam Slider	1	FC250 with Graphite
②	Cam Driver	1	FC250 with Graphite
③	Cam Holder	1	FC250
④	Upper Plate	2	FC250 with Graphite
⑤	Positive Return Follower	2	S45C(1045)
⑥	Stopper Plate	1	S45C(1045)
⑦	Spring Guide Pin	1	φ 14×50
⑧	Coil Spring	1	TL30-125
⑫	Plate	2	S45C(1045)
⑮	Cam Bottom Guide Plate	1	Bronze with Graphite
⑯	Cam Bottom Slide Plate	1	S45C(1045)
⑰	Stopper	2	Urethane

Spring Diagram

- Spring used TL30-125 (1 piece)
 - Spring constant 23.76N/mm (2.42kgf/mm)
 - Guideline of spring durability 300,000 strokes
- α : Spring Force at punch retraction of 5 mm
e : Spring return amount when the punch returns 5 mm

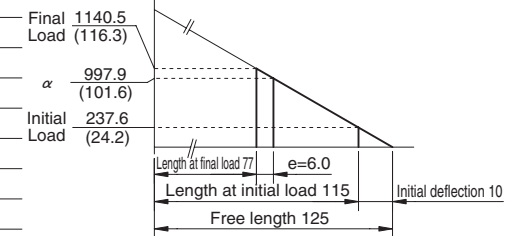

Bolts for assembly are not indicated.

Space for removing

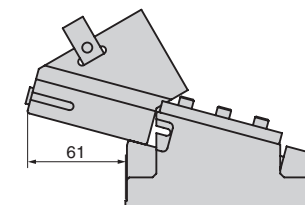

Aerial Cam Unit

FOR PIERCE AND FLANGE

CAD
FILE

UCNBK65 - 15

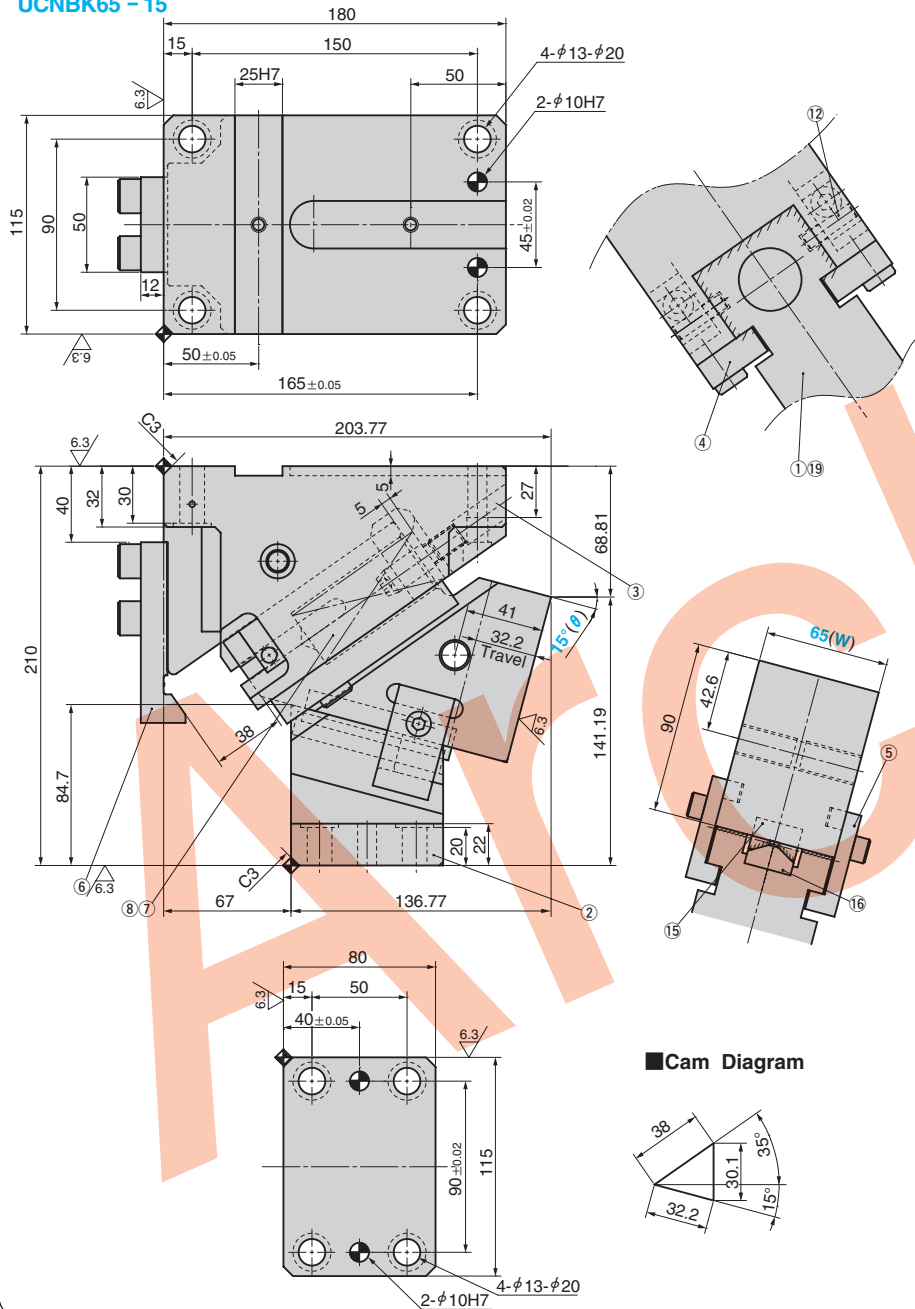

Cam Diagram

Travel S	Working Force kN(tonf)		Spring Force N(kgf)		Return Force N(kgf)	Catalog No.	W	θ
	Standard Working Force (one million strokes)	Allowable Working Force (300,000 strokes)	Initial Load	Final Load				
32.2	19.6 (2.0)	39.2 (4.0)	237.6 (24.2)	1140.5 (116.3)	1533 (156.5)	UCNBK	65	15



Order

Catalog No.	W	θ
UCNBK	65	15



Option

Option Code	Specification
K	Key attached for holder.

For key specification, refer to page 737.



Order

UCNBK65 - 15 - K

Refer to page 389 for detailed specifications of tapped holes and dowel pin holes (prepared hole, finish hole) for retainer.

Table of Components

No.	Description	Qty	Material and Remark
①	Cam Slider	1	FC250 with Graphite
②	Cam Driver	1	FC250 with Graphite
③	Cam Holder	1	FC250
④	Upper Plate	2	FC250 with Graphite
⑤	Positive Return Follower	2	S45C(1045)
⑥	Stopper Plate	1	S45C(1045)
⑦	Spring Guide Pin	1	φ 14×50
⑧	Coil Spring	1	TL30-125
⑫	Plate	2	S45C(1045)
⑮	Cam Bottom Guide Plate	1	Bronze with Graphite
⑯	Cam Bottom Slide Plate	1	S45C(1045)
⑲	Stopper	2	Urethane

Spring Diagram

- Spring used TL30-125 (1 piece)
- Spring constant 23.76N/mm (2.42kgf/mm)
- Guideline of spring durability 300,000 strokes

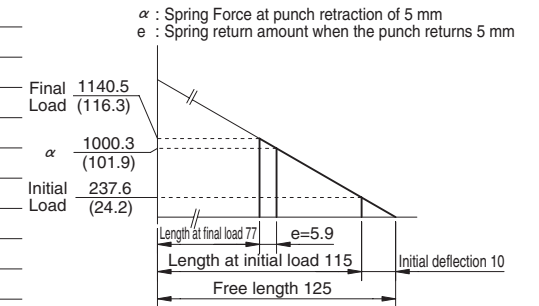

Bolts for assembly are not indicated.

Space for removing

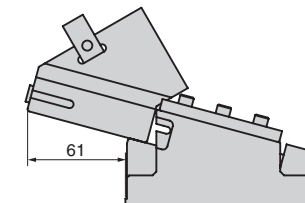

Aerial Cam Unit

FOR PIERCE AND FLANGE

CAD
FILE

UCNBK65 - 20

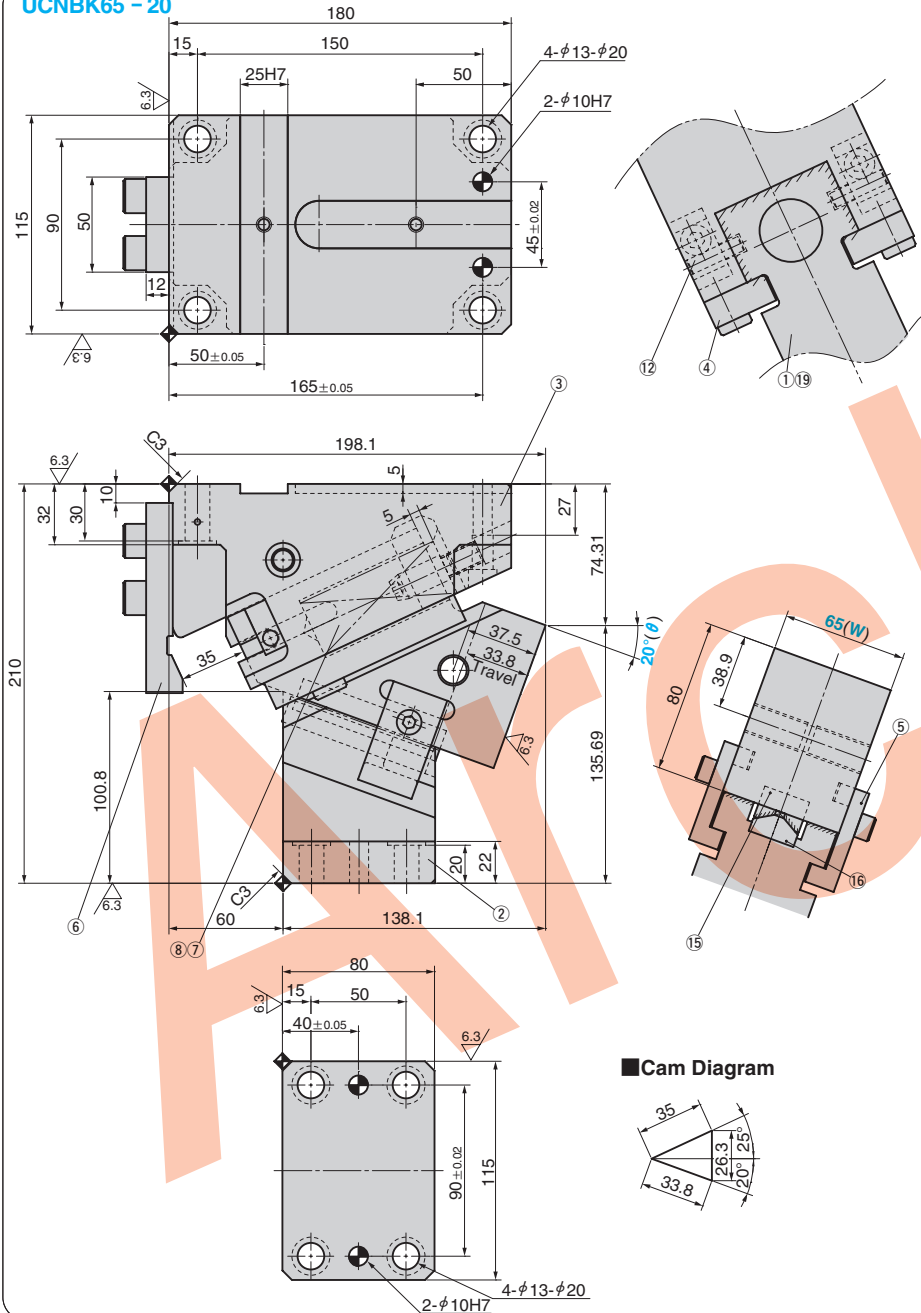

Cam Diagram

Travel S	Working Force kN(tonf)		Spring Force N(kgf)		Return Force N(kgf)	Catalog No.	W	θ
	Standard Working Force (one million strokes)	Allowable Working Force (300,000 strokes)	Initial Load	Final Load				
33.8	19.6 (2.0)	39.2 (4.0)	308.9 (31.5)	1140.5 (116.3)	1417 (144.6)	UCNBK	65	20



Order

Catalog No.	W	θ
UCNBK	65	20



Option

Option Code	Specification
K	Key attached for holder.

For key specification, refer to page 737.



Order

UCNBK65 - 20 - K

Refer to page 389 for detailed specifications of tapped holes and dowel pin holes (prepared hole, finish hole) for retainer.

Table of Components

No.	Description	Qty	Material and Remark
①	Cam Slider	1	FC250 with Graphite
②	Cam Driver	1	FC250 with Graphite
③	Cam Holder	1	FC250
④	Upper Plate	2	FC250 with Graphite
⑤	Positive Return Follower	2	S45C(1045)
⑥	Stopper Plate	1	S45C(1045)
⑦	Spring Guide Pin	1	φ14×50
⑧	Coil Spring	1	TL30-125
⑫	Plate	2	S45C(1045)
⑮	Cam Bottom Guide Plate	1	Bronze with Graphite
⑯	Cam Bottom Slide Plate	1	S45C(1045)
⑲	Stopper	2	Urethane

Spring Diagram

- Spring used TL30-125 (1 piece)
- Spring constant 23.76N/mm (2.42kgf/mm)
- Guideline of spring durability 300,000 strokes

α : Spring Force at punch retraction of 5 mm
e : Spring return amount when the punch returns 5 mm

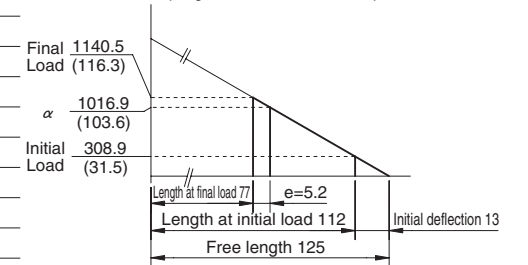

Bolts for assembly are not indicated.

Space for removing

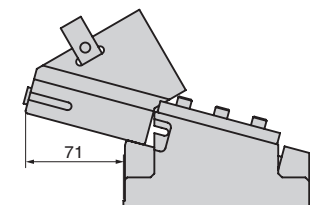

Aerial Cam Unit

FOR PIERCE AND FLANGE

CAD
FILE

UCNBK65 - 25

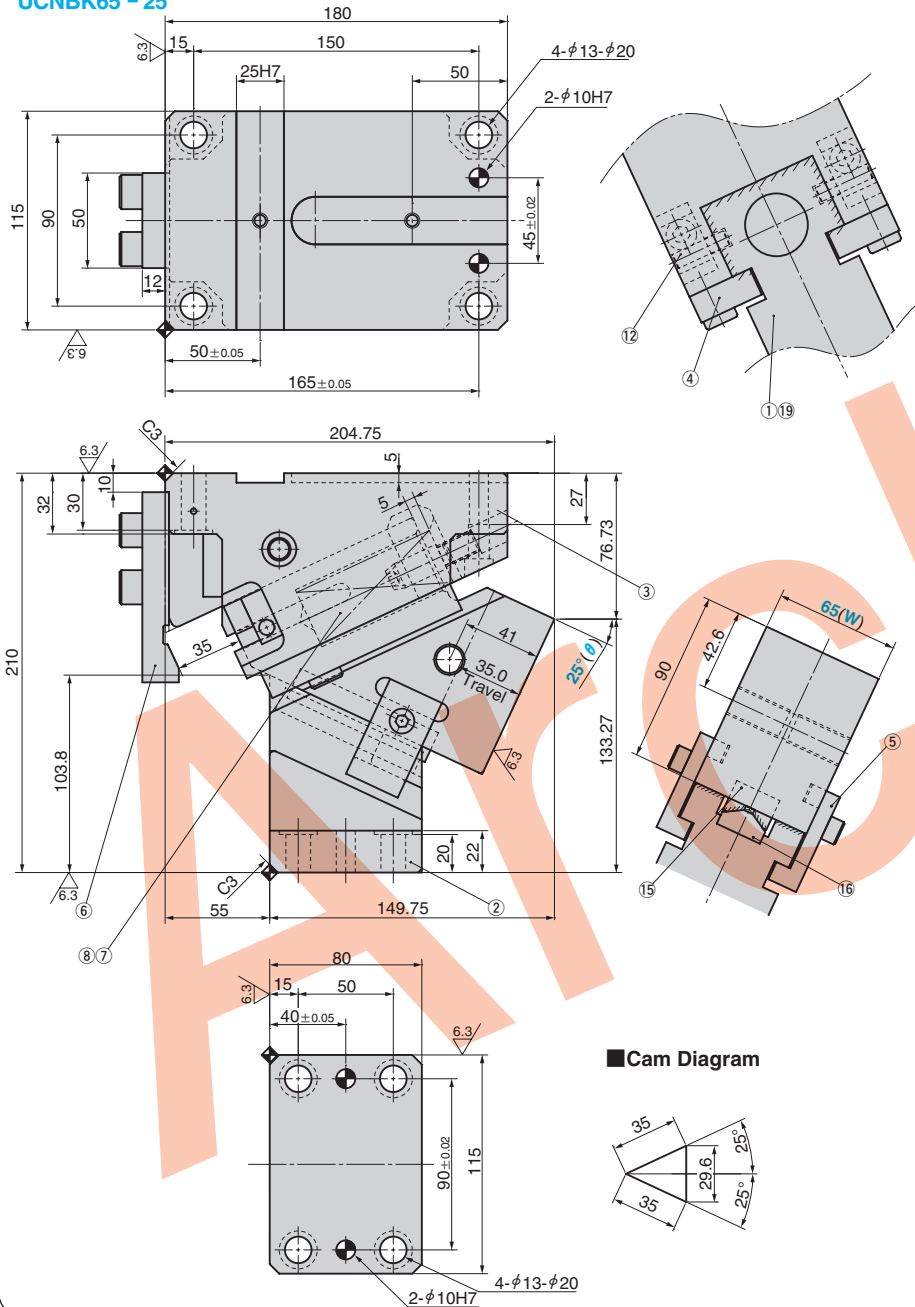

Cam Diagram

Travel S	Working Force kN(tonf)		Spring Force N(kgf)		Return Force N(kgf)	Catalog No.	W	θ
	Standard Working Force (one million strokes)	Allowable Working Force (300,000 strokes)	Initial Load	Final Load				
35.0	19.6 (2.0)	39.2 (4.0)	308.9 (31.5)	1140.5 (116.3)	1522 (155.3)	UCNBK	65	25



Order **Catalog No.** **W** - **θ**
UCNBK 65 - 25



Option Code	Specification
K	Key attached for holder.

For key specification, refer to page 737.



Order **UCNBK65 - 25 - K**

Refer to page 389 for detailed specifications of tapped holes and dowel pin holes (prepared hole, finish hole) for retainer.

Table of Components

No.	Description	Qty	Material and Remark
①	Cam Slider	1	FC250 with Graphite
②	Cam Driver	1	FC250 with Graphite
③	Cam Holder	1	FC250
④	Upper Plate	2	FC250 with Graphite
⑤	Positive Return Follower	2	S45C(1045)
⑥	Stopper Plate	1	S45C(1045)
⑦	Spring Guide Pin	1	φ14×50
⑧	Coil Spring	1	TL30-125
⑫	Plate	2	S45C(1045)
⑮	Cam Bottom Guide Plate	1	Bronze with Graphite
⑯	Cam Bottom Slide Plate	1	S45C(1045)
⑲	Stopper	2	Urethane

Spring Diagram

- Spring used TL30-125 (1 piece)
 - Spring constant 23.76N/mm (2.42kgf/mm)
 - Guideline of spring durability 300,000 strokes
- α : Spring Force at punch retraction of 5 mm
e : Spring return amount when the punch returns 5 mm

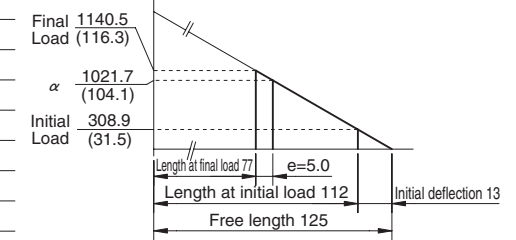

Bolts for assembly are not indicated.

Space for removing

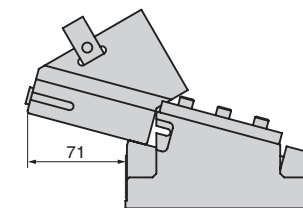

Aerial Cam Unit

FOR PIERCE AND FLANGE

CAD
FILE

UCNBK65 - 30

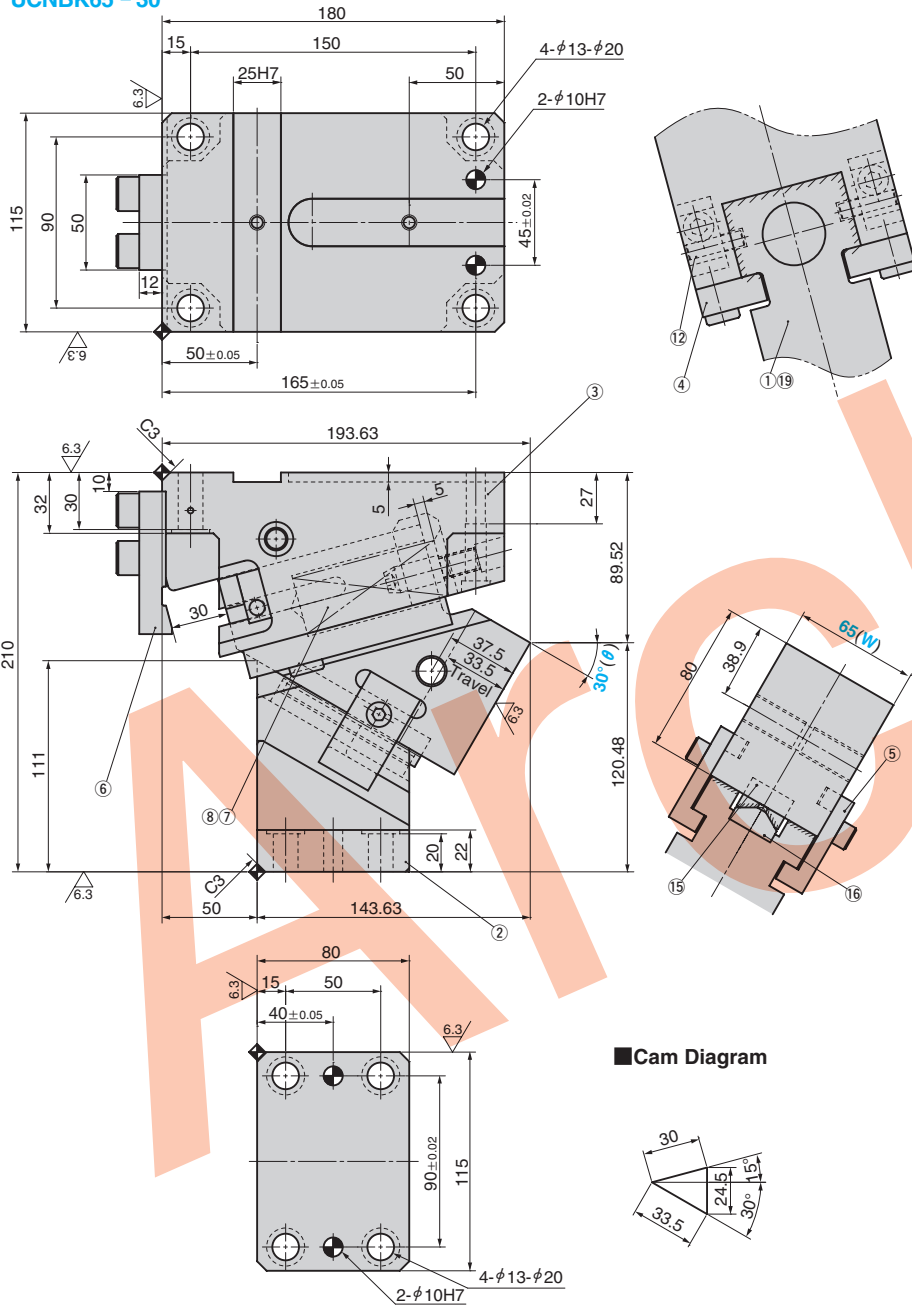

Cam Diagram

Travel S	Working Force kN(tonf)		Spring Force N(kgf)		Return Force N(kgf)	Catalog No.	W	θ
	Standard Working Force (one million strokes)	Allowable Working Force (300,000 strokes)	Initial Load	Final Load				
33.5	19.6 (2.0)	39.2 (4.0)	427.7 (43.6)	1140.5 (116.3)	1406 (143.5)	UCNBK	65	30



Order

Catalog No.	W	θ
UCNBK	65	30



Option

Option Code	Specification
K	Key attached for holder.

For key specification, refer to page 737.



Order

UCNBK65 - 30 - K

Refer to page 389 for detailed specifications of tapped holes and dowel pin holes (prepared hole, finish hole) for retainer.

Table of Components

No.	Description	Qty	Material and Remark
①	Cam Slider	1	FC250 with Graphite
②	Cam Driver	1	FC250 with Graphite
③	Cam Holder	1	FC250
④	Upper Plate	2	FC250 with Graphite
⑤	Positive Return Follower	2	S45C(1045)
⑥	Stopper Plate	1	S45C(1045)
⑦	Spring Guide Pin	1	φ14×50
⑧	Coil Spring	1	TL30-125
⑫	Plate	2	S45C(1045)
⑮	Cam Bottom Guide Plate	1	Bronze with Graphite
⑯	Cam Bottom Slide Plate	1	S45C(1045)
⑲	Stopper	2	Urethane

Spring Diagram

- Spring used TL30-125 (1 piece)
 - Spring constant 23.76N/mm (2.42kgf/mm)
 - Guideline of spring durability 300,000 strokes
- α : Spring Force at punch retraction of 5 mm
e : Spring return amount when the punch returns 5 mm

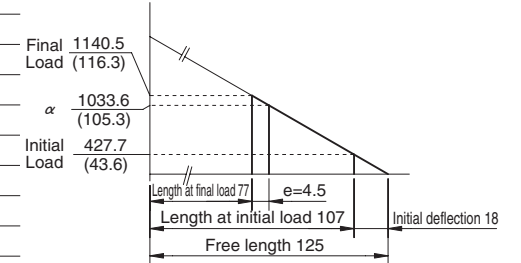

Bolts for assembly are not indicated.

Space for removing

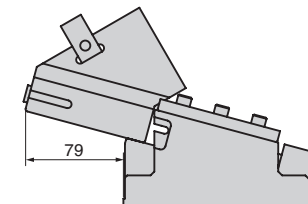

Aerial Cam Unit

FOR PIERCE AND FLANGE

CAD
FILE

UCNBK65 - 35

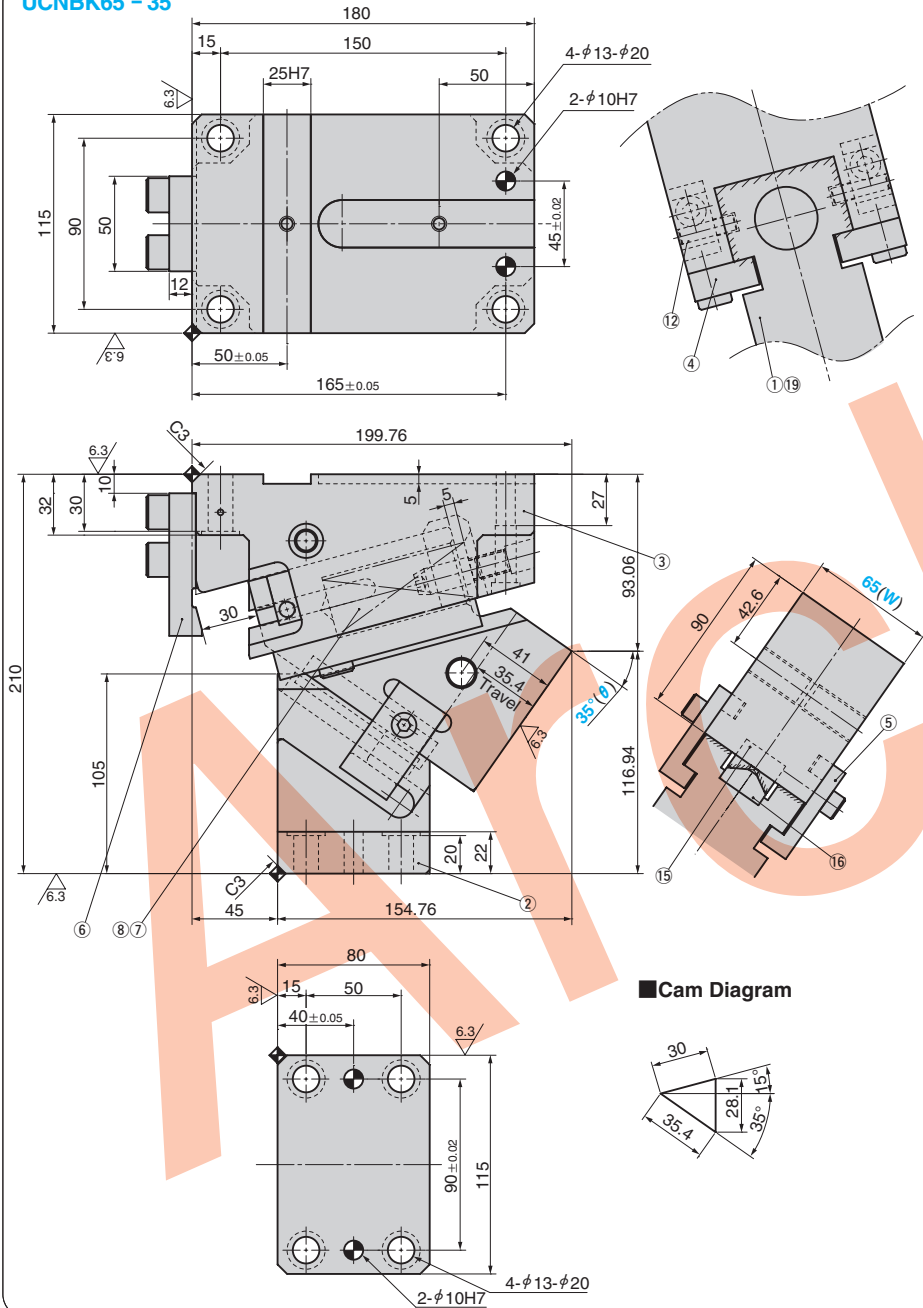

Cam Diagram

Travel S	Working Force kN(tonf)		Spring Force N(kgf)		Return Force N(kgf)	Catalog No.	W	θ
	Standard Working Force (one million strokes)	Allowable Working Force (300,000 strokes)	Initial Load	Final Load				
35.4	19.6 (2.0)	39.2 (4.0)	427.7 (43.6)	1140.5 (116.3)	1510 (154.0)	UCNBK	65	35



Order

Catalog No.	W	θ
UCNBK	65	35



Option

Option Code	Specification
K	Key attached for holder.

For key specification, refer to page 737.



Order

UCNBK65 - 35 - K

Refer to page 389 for detailed specifications of tapped holes and dowel pin holes (prepared hole, finish hole) for retainer.

Table of Components

No.	Description	Qty	Material and Remark
①	Cam Slider	1	FC250 with Graphite
②	Cam Driver	1	FC250 with Graphite
③	Cam Holder	1	FC250
④	Upper Plate	2	FC250 with Graphite
⑤	Positive Return Follower	2	S45C(1045)
⑥	Stopper Plate	1	S45C(1045)
⑦	Spring Guide Pin	1	φ14×50
⑧	Coil Spring	1	TL30-125
⑫	Plate	2	S45C(1045)
⑮	Cam Bottom Guide Plate	1	Bronze with Graphite
⑯	Cam Bottom Slide Plate	1	S45C(1045)
⑲	Stopper	2	Urethane

Spring Diagram

- Spring used TL30-125 (1 piece)
 - Spring constant 23.76N/mm (2.42kgf/mm)
 - Guideline of spring durability 300,000 strokes
- α : Spring Force at punch retraction of 5 mm
e : Spring return amount when the punch returns 5 mm

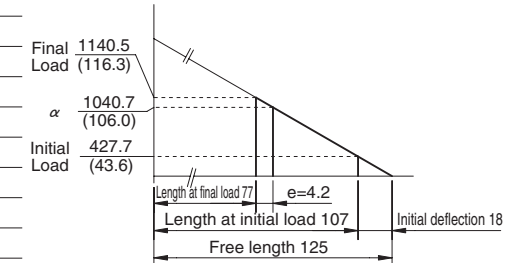

Bolts for assembly are not indicated.

Space for removing

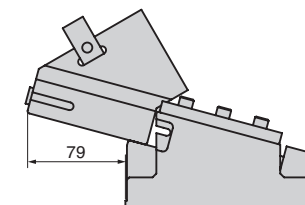

Aerial Cam Unit

FOR PIERCE AND FLANGE

CAD
FILE

UCNBK65 - 40

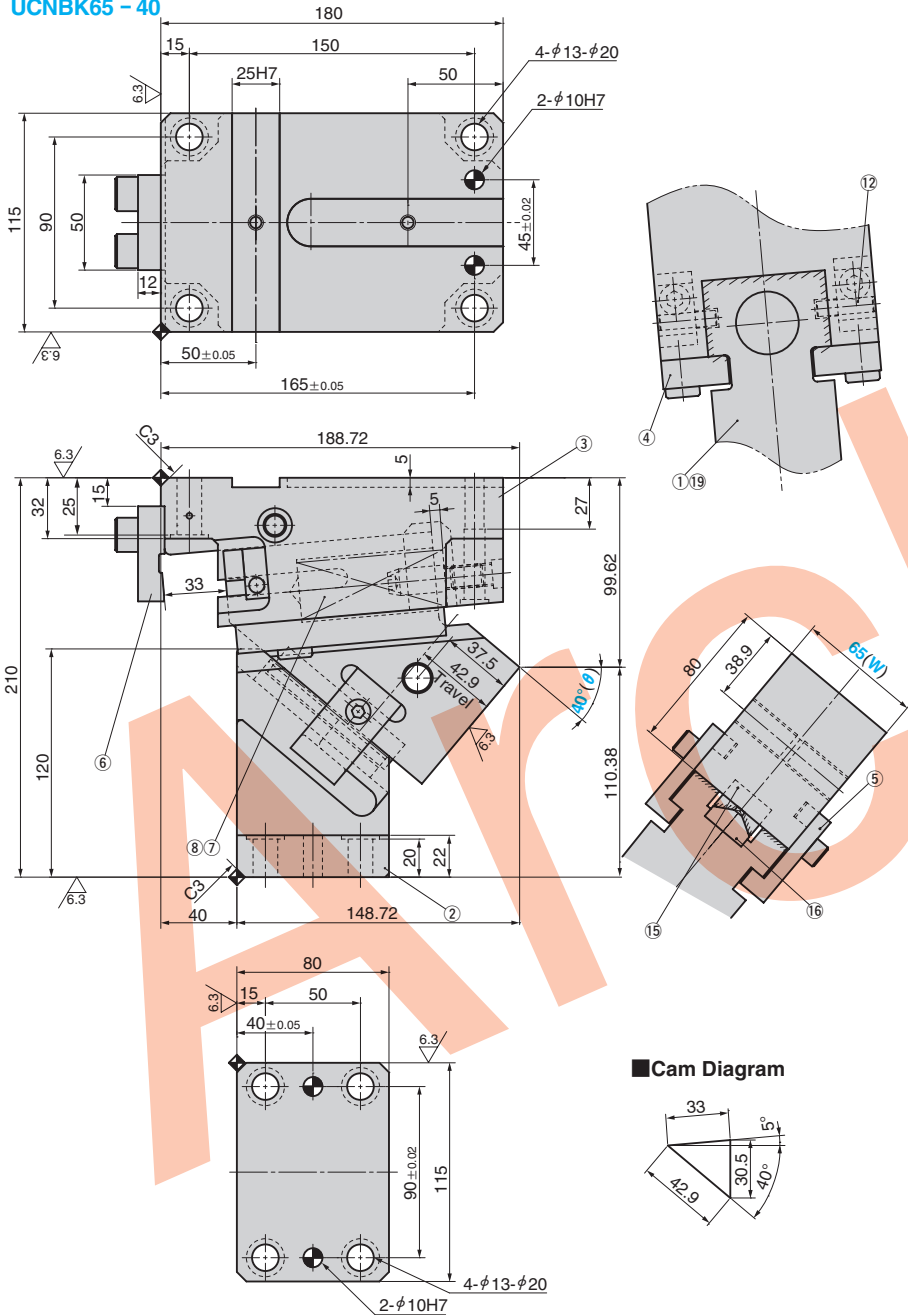

Cam Diagram

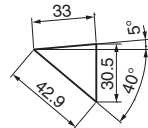

Travel S	Working Force kN(tonf)		Spring Force N(kgf)		Return Force N(kgf)	Catalog No.	W	θ
	Standard Working Force (one million strokes)	Allowable Working Force (300,000 strokes)	Initial Load	Final Load				
42.9	19.6 (2.0)	39.2 (4.0)	356.4 (36.3)	1140.5 (116.3)	1395 (142.4)	UCNBK	65	40



Order

Catalog No.	W	θ
UCNBK	65	40



Option

Option Code	Specification
K	Key attached for holder.

For key specification, refer to page 737.



Order

UCNBK65 - 40 - K

Refer to page 389 for detailed specifications of tapped holes and dowel pin holes (prepared hole, finish hole) for retainer.

Table of Components

No.	Description	Qty	Material and Remark
①	Cam Slider	1	FC250 with Graphite
②	Cam Driver	1	FC250 with Graphite
③	Cam Holder	1	FC250
④	Upper Plate	2	FC250 with Graphite
⑤	Positive Return Follower	2	S45C(1045)
⑥	Stopper Plate	1	S45C(1045)
⑦	Spring Guide Pin	1	φ14×50
⑧	Coil Spring	1	TL30-125
⑫	Plate	2	S45C(1045)
⑮	Cam Bottom Guide Plate	1	Bronze with Graphite
⑯	Cam Bottom Slide Plate	1	S45C(1045)
⑲	Stopper	2	Urethane

Spring Diagram

- Spring used TL30-125 (1 piece)
 - Spring constant 23.76N/mm (2.42kgf/mm)
 - Guideline of spring durability 300,000 strokes
- α : Spring Force at punch retraction of 5 mm
e : Spring return amount when the punch returns 5 mm

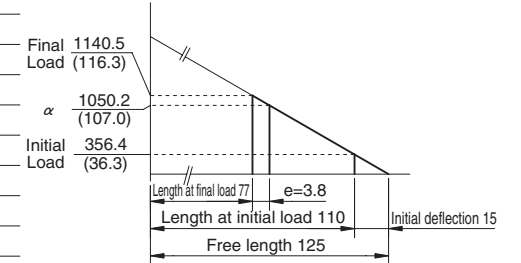

Bolts for assembly are not indicated.

Space for removing

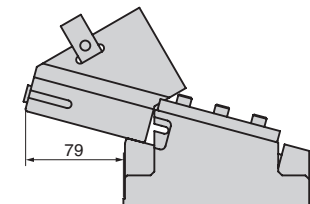

Aerial Cam Unit

FOR PIERCE AND FLANGE

CAD
FILE

UCNBK65 - 45

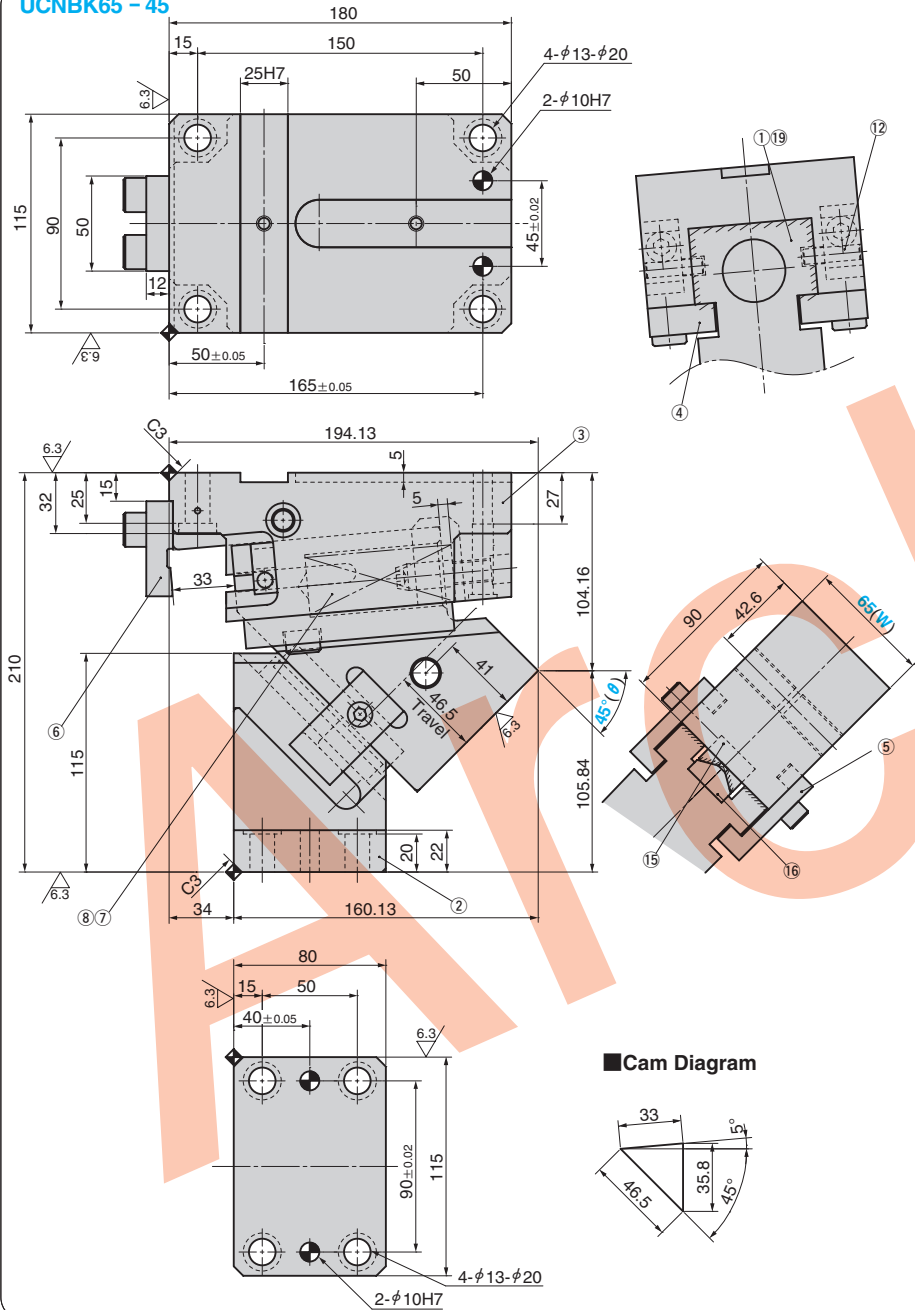

Cam Diagram

Travel S	Working Force kN(tonf)		Spring Force N(kgf)		Return Force N(kgf)	Catalog No.	W	θ
	Standard Working Force (one million strokes)	Allowable Working Force (300,000 strokes)	Initial Load	Final Load				
46.5	19.6 (2.0)	39.2 (4.0)	356.4 (36.3)	1140.5 (116.3)	1497 (152.8)	UCNBK	65	45



Order

Catalog No.	W	θ
UCNBK	65	45



Option

Option Code	Specification
K	Key attached for holder.

For key specification, refer to page 737.



Order

UCNBK65 - 45 - K

Refer to page 389 for detailed specifications of tapped holes and dowel pin holes (prepared hole, finish hole) for retainer.

Table of Components

No.	Description	Qty	Material and Remark
①	Cam Slider	1	FC250 with Graphite
②	Cam Driver	1	FC250 with Graphite
③	Cam Holder	1	FC250
④	Upper Plate	2	FC250 with Graphite
⑤	Positive Return Follower	2	S45C(1045)
⑥	Stopper Plate	1	S45C(1045)
⑦	Spring Guide Pin	1	φ14×50
⑧	Coil Spring	1	TL30-125
⑫	Plate	2	S45C(1045)
⑮	Cam Bottom Guide Plate	1	Bronze with Graphite
⑯	Cam Bottom Slide Plate	1	S45C(1045)
⑲	Stopper	2	Urethane

Bolts for assembly are not indicated.

Spring Diagram

- Spring used TL30-125 (1 piece)
 - Spring constant 23.76N/mm (2.42kgf/mm)
 - Guideline of spring durability 300,000 strokes
- α : Spring Force at punch retraction of 5 mm
e : Spring return amount when the punch returns 5 mm

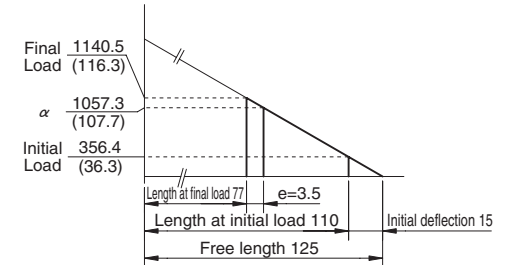

Space for removing

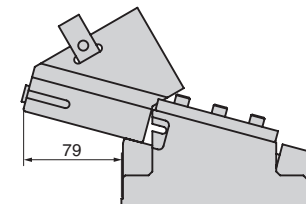

Aerial Cam Unit

FOR PIERCE AND FLANGE

CAD
FILE

UCNBK65 - 50

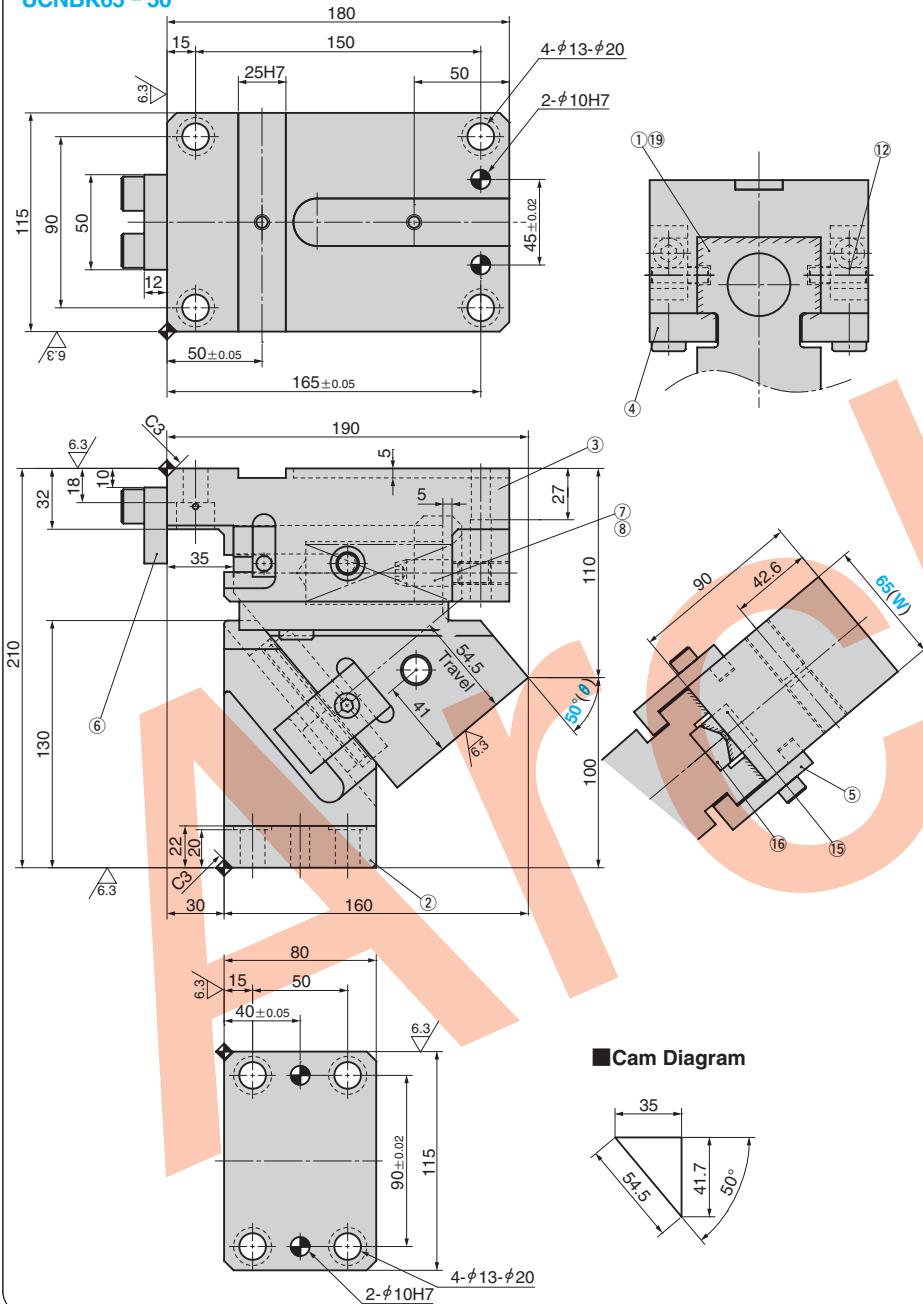

Cam Diagram

Travel S	Working Force kN(tonf)		Spring Force N(kgf)		Return Force N(kgf)	Catalog No.	W	θ
	Standard Working Force (one million strokes)	Allowable Working Force (300,000 strokes)	Initial Load	Final Load				
54.5	19.6 (2.0)	39.2 (4.0)	308.9 (31.5)	1140.5 (116.3)	1491 (152.1)	UCNBK	65	50

Order

Catalog No.	W	θ
UCNBK	65	50

Option

Option Code	Specification
K	Key attached for holder.

For key specification, refer to page 737.

Order **UCNBK65 - 50 - K**

Refer to page 389 for detailed specifications of tapped holes and dowel pin holes (prepared hole, finish hole) for retainer.

Table of Components

No.	Description	Qty	Material and Remark
①	Cam Slider	1	FC250 with Graphite
②	Cam Driver	1	FC250 with Graphite
③	Cam Holder	1	FC250
④	Upper Plate	2	FC250 with Graphite
⑤	Positive Return Follower	2	S45C(1045)
⑥	Stopper Plate	1	S45C(1045)
⑦	Spring Guide Pin	1	φ14×50
⑧	Coil Spring	1	TL30-125
⑫	Plate	2	S45C(1045)
⑮	Cam Bottom Guide Plate	1	Bronze with Graphite
⑯	Cam Bottom Slide Plate	1	S45C(1045)
⑲	Stopper	2	Urethane

Spring Diagram

- Spring used TL30-125 (1 piece)
 - Spring constant 23.76N/mm (2.42kgf/mm)
 - Guideline of spring durability 300,000 strokes
- α : Spring Force at punch retraction of 5 mm
e : Spring return amount when the punch returns 5 mm

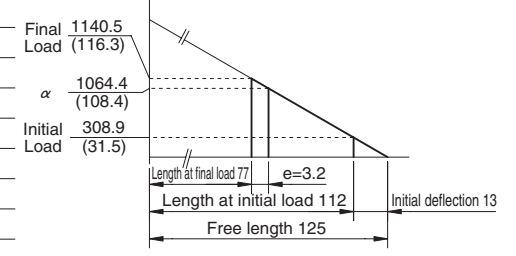

Bolts for assembly are not indicated.

Space for removing

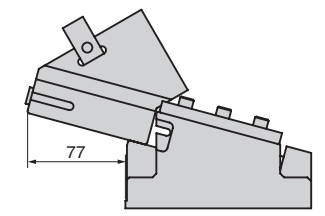

Aerial Cam Unit

FOR PIERCE AND FLANGE

CAD
FILE

UCNBK65 - 55

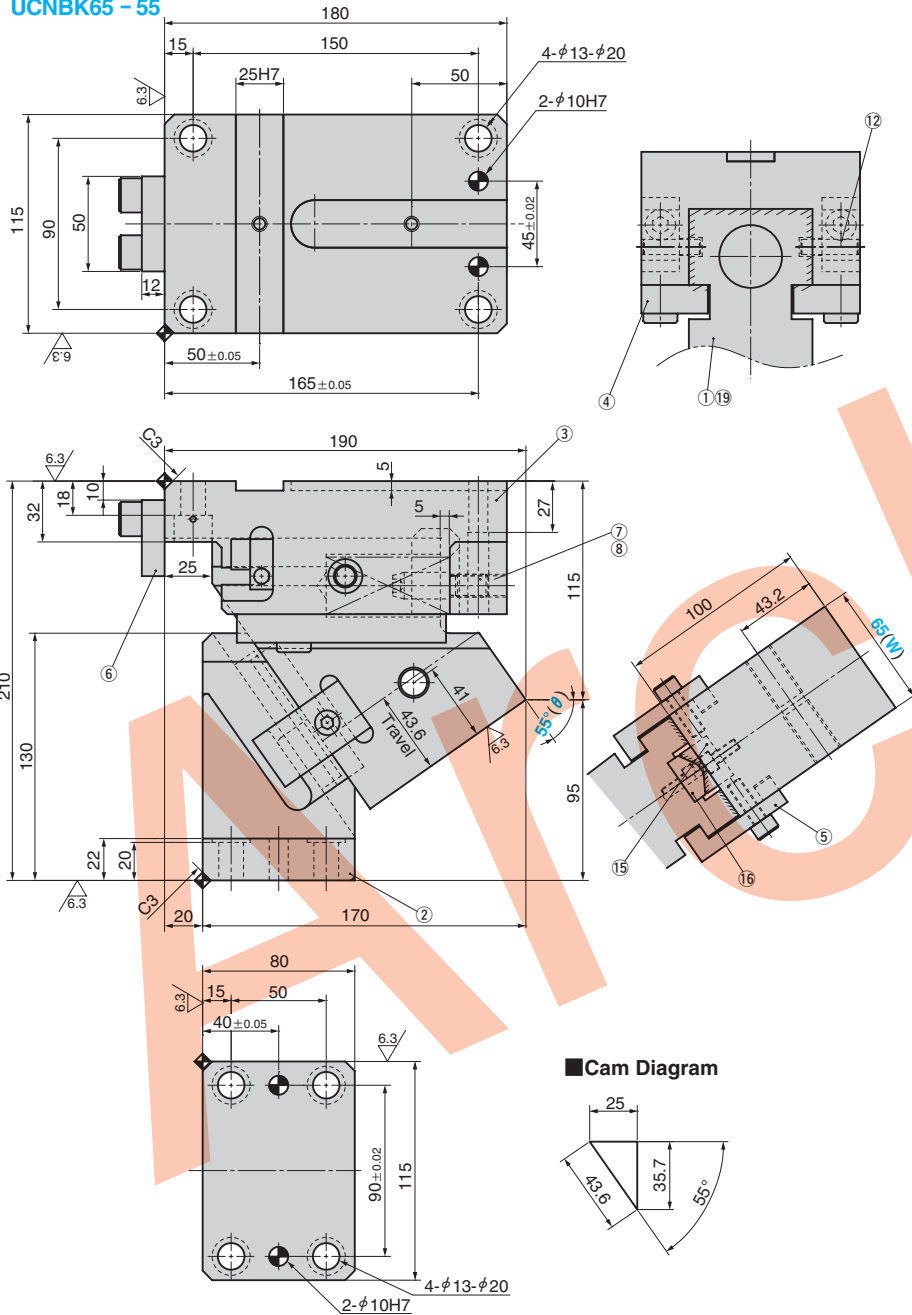

Cam Diagram

Travel S	Working Force kN(tonf)		Spring Force N(kgf)		Return Force N(kgf)	Catalog No.	W	θ
	Standard Working Force (one million strokes)	Allowable Working Force (300,000 strokes)	Initial Load	Final Load				
43.6	19.6 (2.0)	39.2 (4.0)	296.9 (30.3)	1039.2 (106.0)	1480 (151.0)	UCNBK	65	55



Order

Catalog No.	W	θ
UCNBK	65	55



Option

Option Code	Specification
K	Key attached for holder.

For key specification, refer to page 737.



Order

UCNBK65 - 55 - K

Refer to page 389 for detailed specifications of tapped holes and dowel pin holes (prepared hole, finish hole) for retainer.

Table of Components

No.	Description	Qty	Material and Remark
①	Cam Slider	1	FC250 with Graphite
②	Cam Driver	1	FC250 with Graphite
③	Cam Holder	1	FC250
④	Upper Plate	2	FC250 with Graphite
⑤	Positive Return Follower	2	S45C(1045)
⑥	Stopper Plate	1	S45C(1045)
⑦	Spring Guide Pin	1	φ14×50
⑧	Coil Spring	1	TL30-100
⑫	Plate	2	S45C(1045)
⑮	Cam Bottom Guide Plate	1	Bronze with Graphite
⑯	Cam Bottom Slide Plate	1	S45C(1045)
⑰	Stopper	2	Urethane

Spring Diagram

- Spring used TL30-100 (1 piece)
 - Spring constant 29.69N/mm (3.03kgf/mm)
 - Guideline of spring durability 500,000 strokes
- α : Spring Force at punch retraction of 5 mm
e : Spring return amount when the punch returns 5 mm

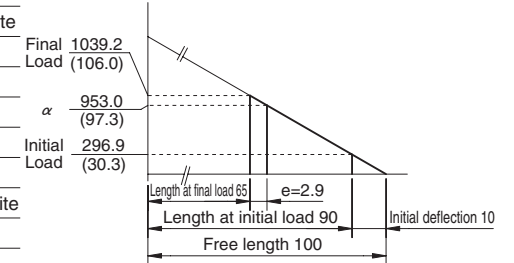

Bolts for assembly are not indicated.

Space for removing

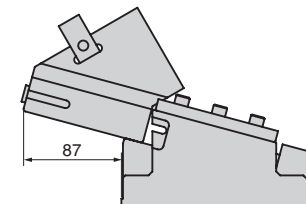

Aerial Cam Unit

FOR PIERCE AND FLANGE

CAD
FILE

UCNBK65 - 60

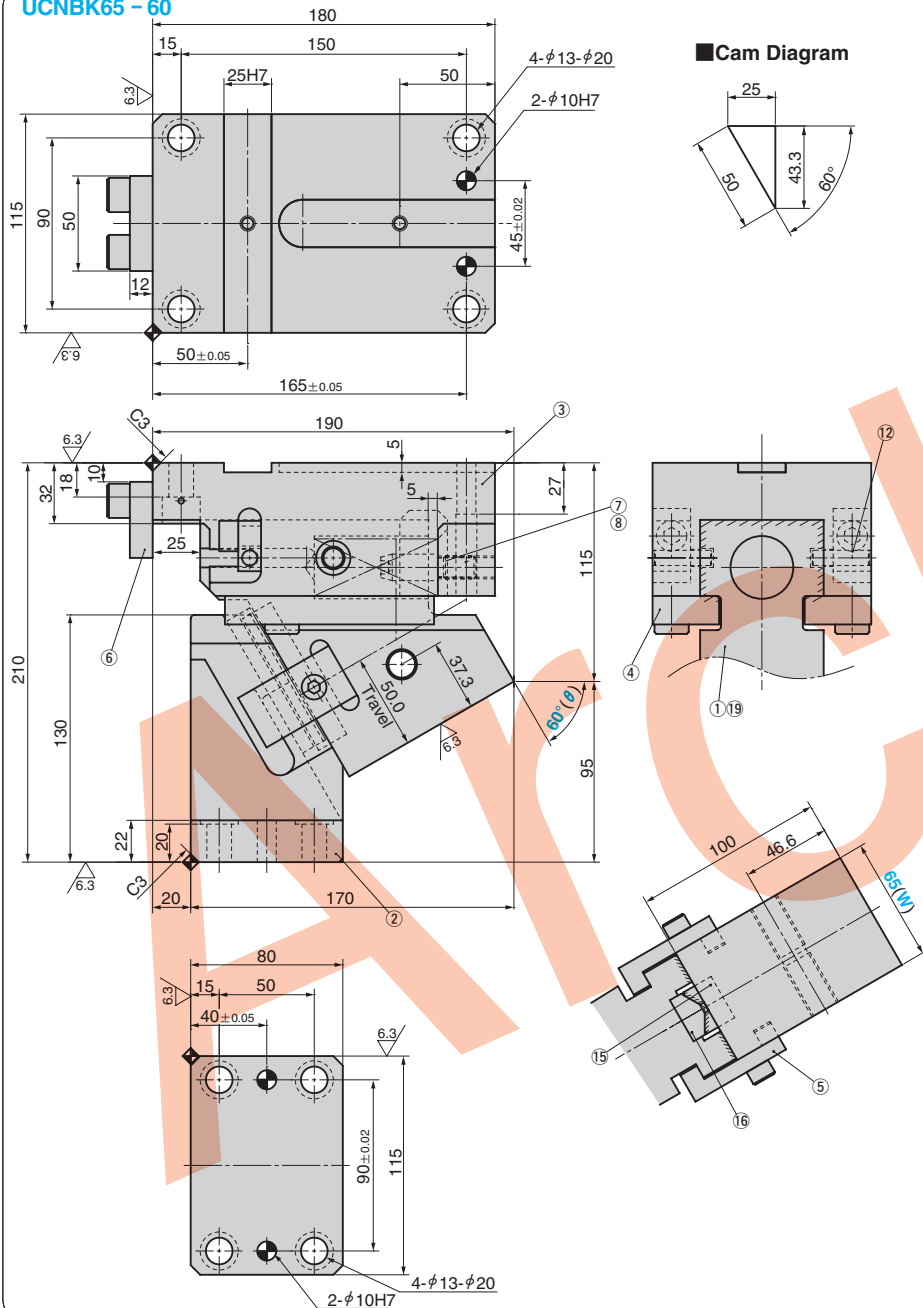

Travel S	Working Force kN(tonf)		Spring Force N(kgf)		Return Force N(kgf)	Catalog No.	W	θ
	Standard Working Force (one million strokes)	Allowable Working Force (300,000 strokes)	Initial Load	Final Load				
50.0	19.6 (2.0)	39.2 (4.0)	296.9 (30.3)	1039.2 (106.0)	1637 (167.0)	UCNBK	65	60



Order

Catalog No.	W	θ
UCNBK	65	60



Option

Option Code	Specification
K	Key attached for holder.

For key specification, refer to page 737.



Order

UCNBK65 - 60 - K

Refer to page 389 for detailed specifications of tapped holes and dowel pin holes (prepared hole, finish hole) for retainer.

Table of Components

No.	Description	Qty	Material and Remark
①	Cam Slider	1	FC250 with Graphite
②	Cam Driver	1	FC250 with Graphite
③	Cam Holder	1	FC250
④	Upper Plate	2	FC250 with Graphite
⑤	Positive Return Follower	2	S45C(1045)
⑥	Stopper Plate	1	S45C(1045)
⑦	Spring Guide Pin	1	φ14×50
⑧	Coil Spring	1	TL30-100
⑫	Plate	2	S45C(1045)
⑮	Cam Bottom Guide Plate	1	Bronze with Graphite
⑯	Cam Bottom Slide Plate	1	S45C(1045)
⑰	Stopper	2	Urethane

Spring Diagram

- Spring used TL30-100 (1 piece)
 - Spring constant 29.69N/mm (3.03kgf/mm)
 - Guideline of spring durability 500,000 strokes
- α : Spring Force at punch retraction of 5 mm
e : Spring return amount when the punch returns 5 mm

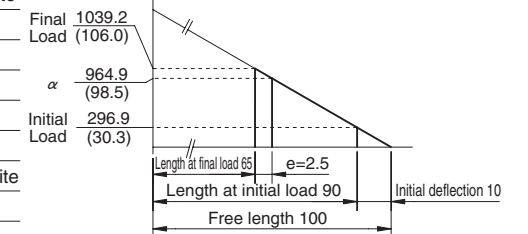

Bolts for assembly are not indicated.

Space for removing

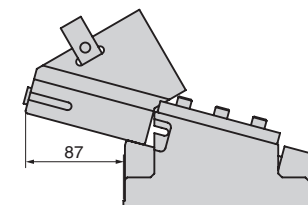

Aerial Cam Unit

FOR PIERCE AND FLANGE

CAD
FILE

UCNBK65 - 65

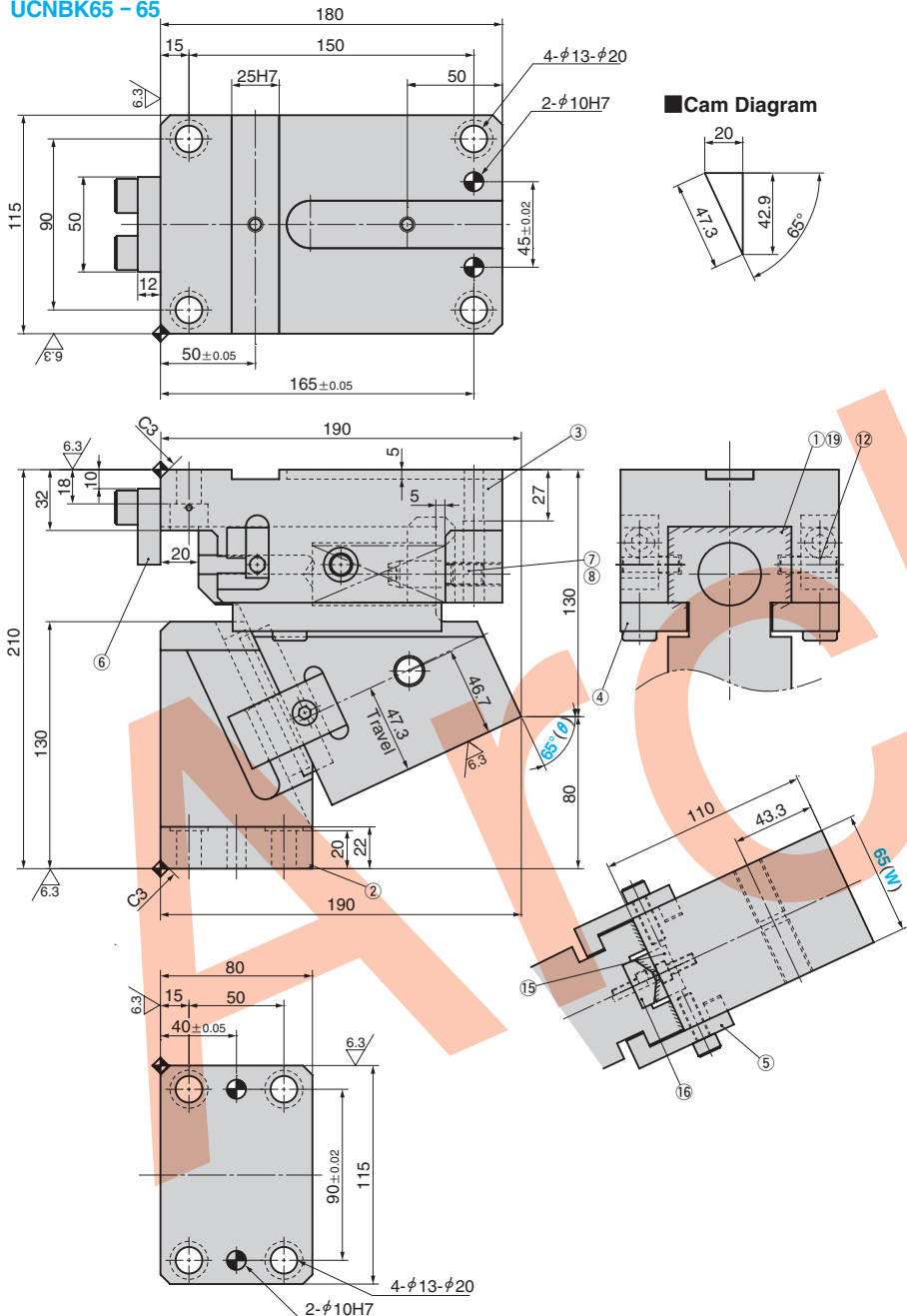

Cam Diagram

Travel S	Working Force kN(tonf)		Spring Force N(kgf)		Return Force N(kgf)	Catalog No.	W	θ
	Standard Working Force (one million strokes)	Allowable Working Force (300,000 strokes)	Initial Load	Final Load				
47.3	19.6 (2.0)	39.2 (4.0)	296.9 (30.3)	890.7 (90.8)	1576 (160.8)	UCNBK	65	65



Order

Catalog No.	W	θ
UCNBK	65	65



Option

Option Code	Specification
K	Key attached for holder.

For key specification, refer to page 737.



Order

UCNBK65 - 65 - K

Refer to page 389 for detailed specifications of tapped holes and dowel pin holes (prepared hole, finish hole) for retainer.

Table of Components

No.	Description	Qty	Material and Remark
①	Cam Slider	1	FC250 with Graphite
②	Cam Driver	1	FC250 with Graphite
③	Cam Holder	1	FC250
④	Upper Plate	2	FC250 with Graphite
⑤	Positive Return Follower	2	S45C(1045)
⑥	Stopper Plate	1	S45C(1045)
⑦	Spring Guide Pin	1	$\phi 14 \times 50$
⑧	Coil Spring	1	TL30-100
⑫	Plate	2	S45C(1045)
⑮	Cam Bottom Guide Plate	1	Bronze with Graphite
⑯	Cam Bottom Slide Plate	1	S45C(1045)
⑰	Stopper	2	Urethane

Spring Diagram

- Spring used TL30-100 (1 piece)
- Spring constant 29.69N/mm (3.03kgf/mm)
- Guideline of spring durability 1,000,000 strokes

α : Spring Force at punch retraction of 5 mm
e : Spring return amount when the punch returns 5 mm

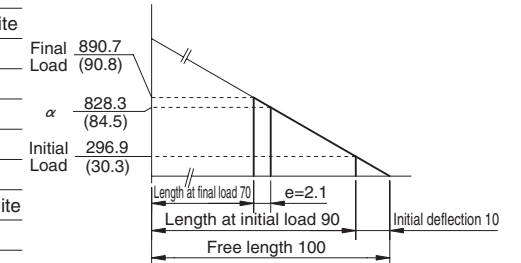

Bolts for assembly are not indicated.

Space for removing

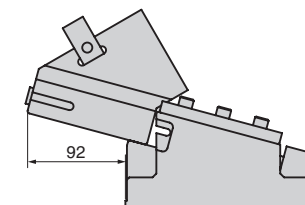

Aerial Cam Unit

FOR PIERCE AND FLANGE

CAD
FILE

UCNBK65 - 70

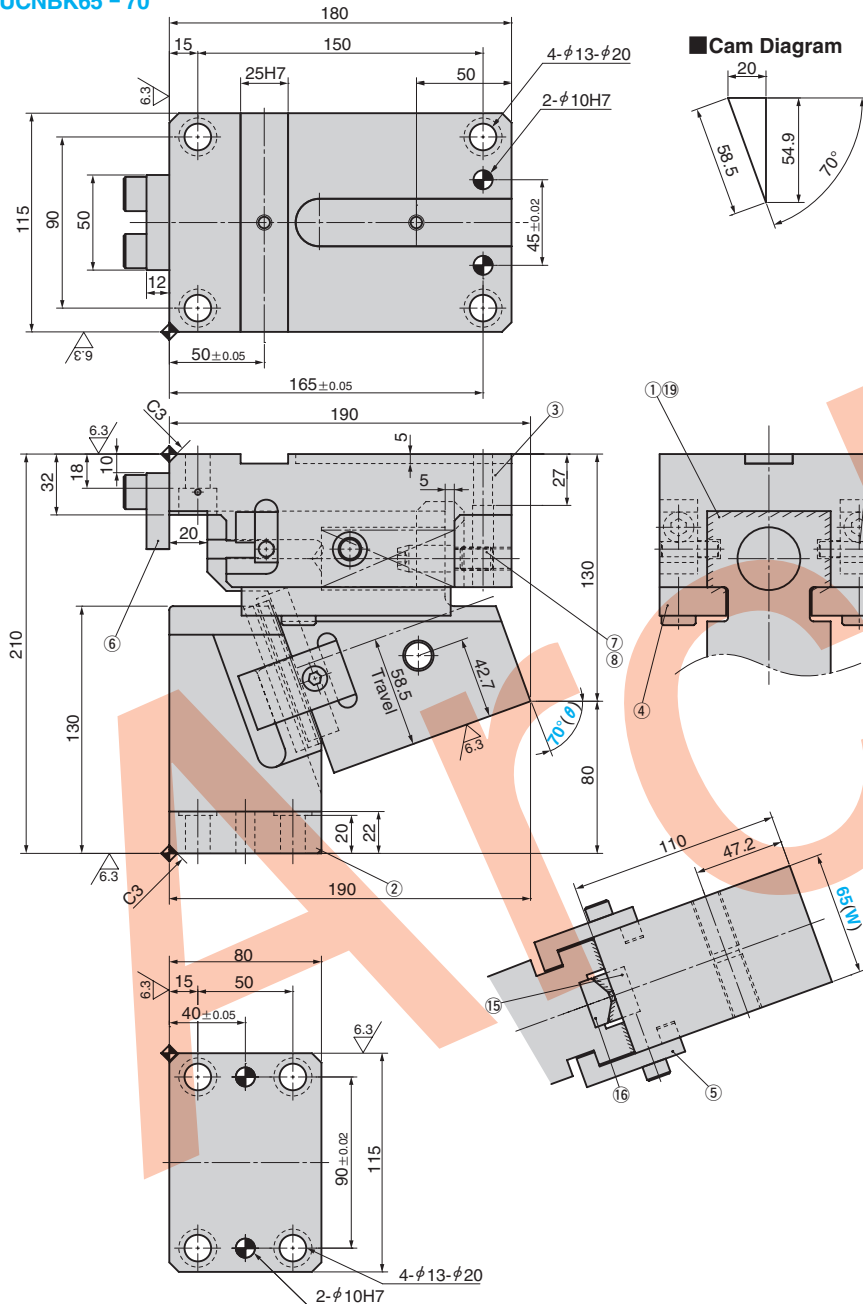

Travel S	Working Force kN(tonf)		Spring Force N(kgf)		Return Force N(kgf)	Catalog No.	W	θ
	Standard Working Force (one million strokes)	Allowable Working Force (300,000 strokes)	Initial Load	Final Load				
58.5	19.6 (2.0)	39.2 (4.0)	296.9 (30.3)	890.7 (90.8)	1824 (186.1)	UCNBK	65	70



Order **Catalog No.** **W** - **θ**
UCNBK 65 - 70



Option **Option Code** **Specification**
K Key attached for holder.

For key specification, refer to page 737.



Order **UCNBK65 - 70 - K**

Refer to page 389 for detailed specifications of tapped holes and dowel pin holes (prepared hole, finish hole) for retainer.

Table of Components

No.	Description	Qty	Material and Remark
①	Cam Slider	1	FC250 with Graphite
②	Cam Driver	1	FC250 with Graphite
③	Cam Holder	1	FC250
④	Upper Plate	2	FC250 with Graphite
⑤	Positive Return Follower	2	S45C(1045)
⑥	Stopper Plate	1	S45C(1045)
⑦	Spring Guide Pin	1	φ14×50
⑧	Coil Spring	1	TL30-100
⑫	Plate	2	S45C(1045)
⑮	Cam Bottom Guide Plate	1	Bronze with Graphite
⑯	Cam Bottom Slide Plate	1	S45C(1045)
⑰	Stopper	2	Urethane

Spring Diagram

- Spring used TL30-100 (1 piece)
 - Spring constant 29.69N/mm (3.03kgf/mm)
 - Guideline of spring durability 1,000,000 strokes
- α : Spring Force at punch retraction of 5 mm
e : Spring return amount when the punch returns 5 mm

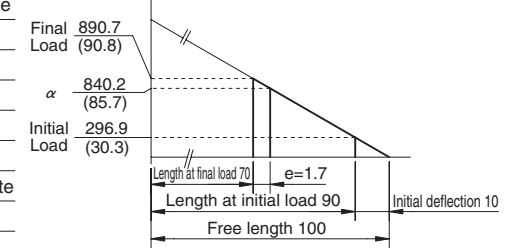

⚠ Bolts for assembly are not indicated.

Space for removing

