

- SVSC complies with the VDI-BAK specification.
    - Specification of Guide Plate complies with VDI3357.
    - Specification of Gas Spring complies with VDI3003.
  - V-shaped guides.
  - 50, 85, 110, 150, 220, 330mm and 400mm mounting widths are available.
  - Available angle are 0° to 20° in increments of 5°.
  - Designed to facilitate easy removal of gas spring. (Disassembly of cam is unnecessary)
  - Heavy duty type : high working force / return force.
- Made-to-order product.

### SVSC Specifications

Mounting Surface		Working Angle	Travel	Working Force kN(tonf)
W	H			Standard Working Force (one million strokes)
50	75		55	29.4(3.0)
85	85			58.8(6.0)
110		00	70	117.7(12.0)
		05		
150	110	10		
		15		
220		20		245.2(25.0)
330			80	343.2(35.0)
400	180			
				431.5(44.0)

### SVSC50/85 Structure and Assembly / Disassembly

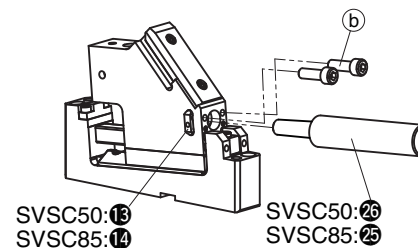
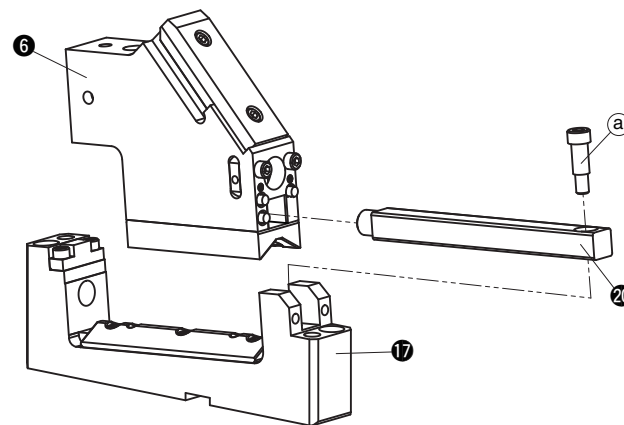

- Note) Only spring can be removed.
- 1) Remove hexagon socket head bolt (b).
  - 2) Pull out the spring stopper (13).
  - 3) Pull out the gas spring (SVSC 50:26, SVSC85:25).

#### Disassembly method of SVSC50/85

- 1) Remove hexagon socket head bolt (a) and pull guide bar (20) from cam holder (17) 20mm to the rear. Remove the guide bar and cam slider (20 6).
- 2) Pull and remove the guide bar from the cam slider.

#### Assembly method of SVSC50/85

- 1) Assemble components in the reverse order of disassembly.
  - Make sure that there is no foreign material on the sliding area and assemble components.
  - The clearance between the guide bar / cam slider and the cam holder is adjusted. Match the stamped serial number on the holder and slider before assembly.
  - After reassembling, please ensure that all bolts removed are re-installed and tightened.

### ■SVSC110/150/220/330/400 Structure and Assembly / Disassembly

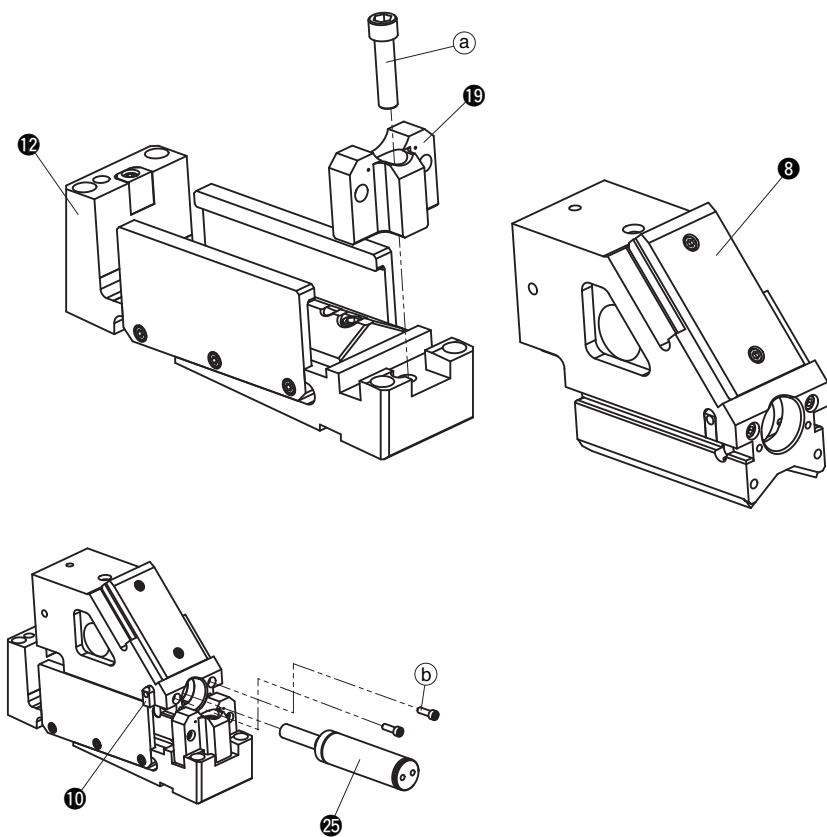

#### ● Disassembly method of SVSC110/150/220/330/400

- 1) Remove hexagon socket head bolt (a) and remove stopper plate (19).
- 2) Pull and remove the cam slider (8) from the cam holder (12) to the rear.

#### ● Assembly method of SVSC110/150/220/330/400

- 1) Assemble components in the reverse order of disassembly.
  - Make sure that there is no foreign material on the sliding area and assemble components.
  - The clearance between the guide bar / cam slider and the cam holder is adjusted. Match the stamped serial number on the holder and slider before assembly.

※ This figure shows SVSC110

Note) Only spring can be removed.

- 1) Remove hexagon socket head bolt (b).
- 2) Pull out the spring stopper (10).
- 3) Pull out the gas spring (25).

SVSC220 (00°~20°)

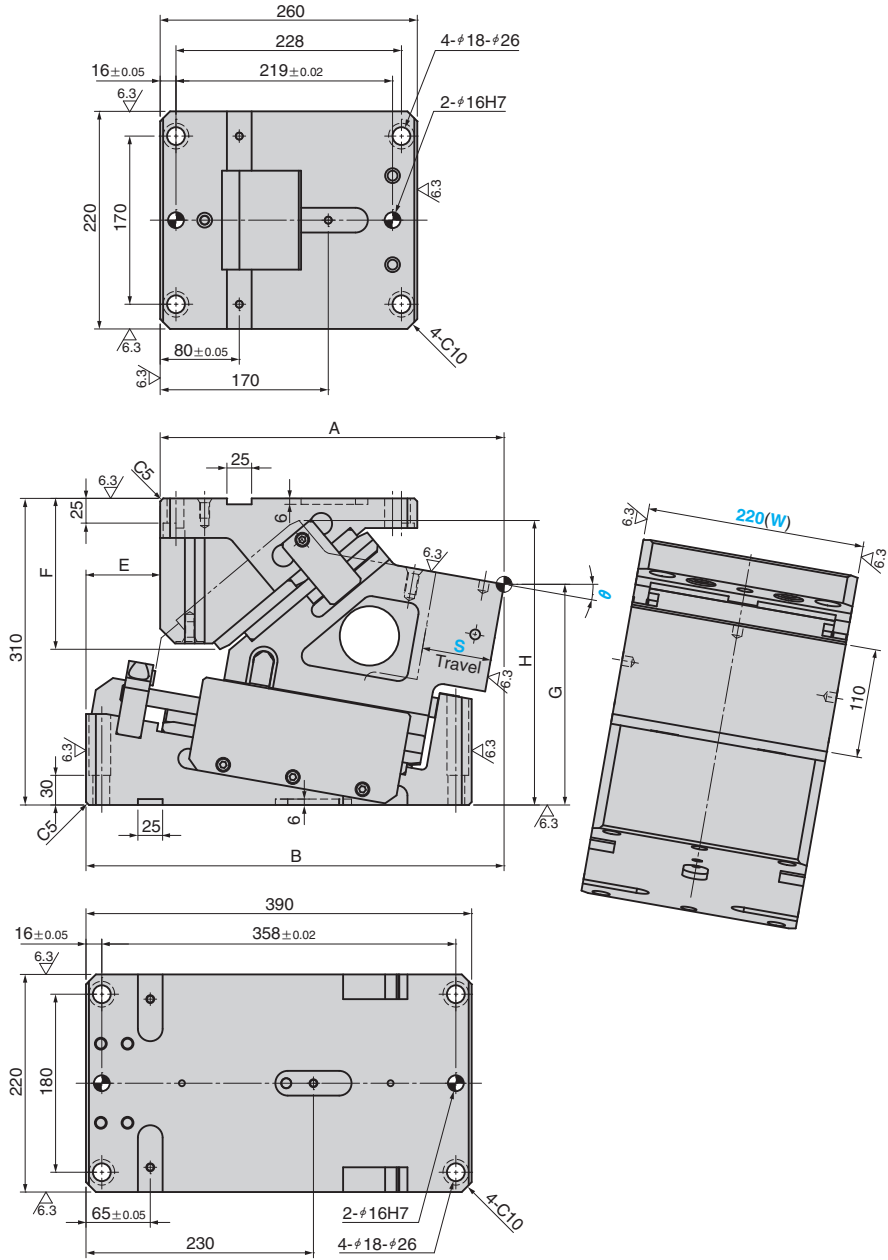

$\theta$	A	B	E	F	G	H
00	355.00	390.00	35	177.6	247.00	274.5
05	356.59	406.59	50	165.9	234.56	280.7
10	347.76	422.76	75	152.6	223.13	287.6
15	348.41	433.41	85	138.6	211.75	294.1
20	346.46	443.46	97	124.3	200.47	300.0

kN(tonf)	Cam Slider Weight kg	Total Weight kg	Catalog No.	(W)	$\theta$	Travel S	Spring Type PS	
245.2 (25.0)	60.3	139	SVSC	220	10	70	00	
		140					05	
		141					10	GK GD NGP*
		145					15	GS
		150					20	

Order **Catalog No.** (W) -  $\theta$  - S - PS  
**SVSC 220 - 10 - 70 - GK**

\* Without gas spring but accessories for installation are included.

Spring Specification(Qty 2)

Gas Spring(Standard)				Gas Spring(Power option "V")			
Spring Type PS	Spring Force N(kgf)		Model	Spring Type PS	Spring Force N(kgf)		Model
	Initial Force	Final Force			Initial Force	Final Force	
GK	-	13400 (1367.3)	TU500-080(KALLER)	GK	-	23800 (2428.6)	X750-080(KALLER)
GD	-	12200 (1244.9)	90.10.00500.080(DADCO)	GD	-	22720 (2318.4)	U.0800.080(DADCO)
GS	-	13200 (1346.9)	SGF.500.80(SDT)	GS	-	24300 (2479.6)	SFC.750.80(SDT)

\* Power gas spring available. Please contact us for details.



Option Code	Specification
<b>K</b>	Dedicated key is attached. (It is not assembled to the main unit)
<b>NF</b>	Nitrogen gas is not charged. Applicable to GK,GS and GD only.
<b>V</b>	Gas Spring is changed to Power type.

Key Specification(Option)  
(Qty 6 with M8×15 bolt)

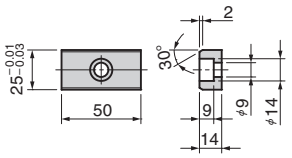

Order **SVSC220 - 10 - 70 - GK - NF - K**  
**SVSC220 - 10 - 70 - GK - V**

## Cam Diagram

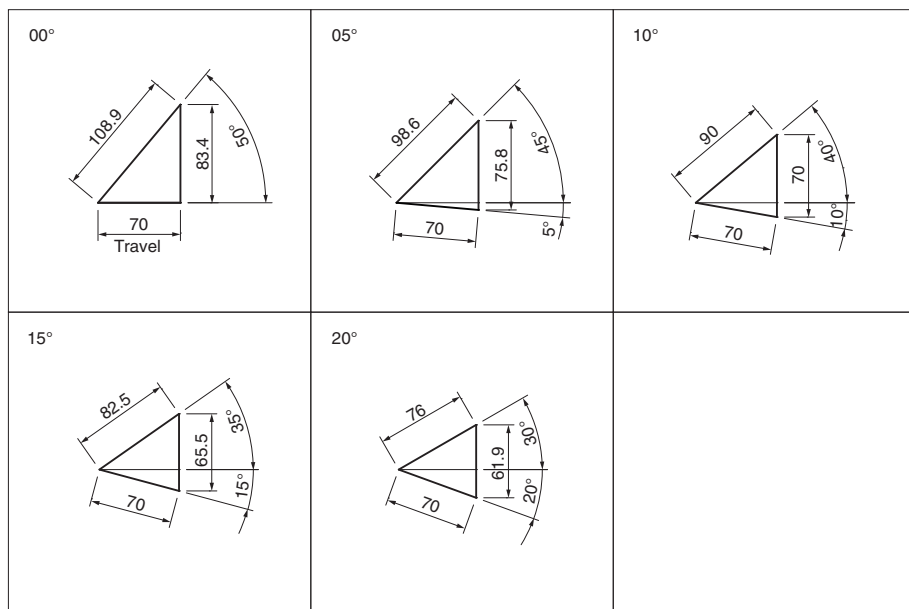

## Required space for removing

Working Angle 00°

Working Angle 05°~20°

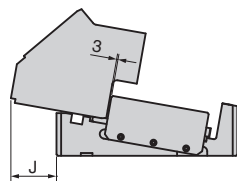
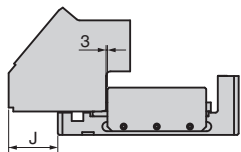

Working Angle	J
00°	106
05°	104
10°	98
15°	94
20°	87

## Table of Components

No.	Description	Qty	Material and Remark	No.	Description	Qty	Material and Remark
①	Cam Driver	1	GGG60(FCD600)	⑮	Cam Holder	1	GGG60(FCD600)
②	Slide Plate	2	Bronze With Graphite(VSM-32-SP2)	⑯	Spring Block	2	S45C HRC55~
④	Slide Plate	2	Bronze With Graphite(VSM-31-SP2)	⑱	Cam Slide Guide(Lower)	1	S45C HRC55~
⑤	Cam Positive Return	2	S45C HRC28~	⑳	Slide Plate	4	SCM440(VSM-53-ST01)
⑦	Cam Slider	1	GGG60(FCD600)	㉑	Keeper Plate	2	S45C HRC28~
⑧	Slide Plate	2	SCM440(VSM-64-ST01)	㉒	Cam Slider Stopper	1	S45C
⑨	Spring Stopper	1	S45C (LH)	㉓	Stopper	2	Urethane
⑫	Spring Stopper	1	S45C (RH)	㉔	Lock Spacer	2	SS400
⑬	Slide Plate	2	Bronze With Graphite(VSM-20-SP2)	㉕	Gas Spring	2	Refer to the Spring Specification Table.
⑭	Slide Plate	2	Bronze With Graphite(VSM-25-SP2)				

