

# Guide Bushing and Clamp

## European Standard

9834 (DIN9834)

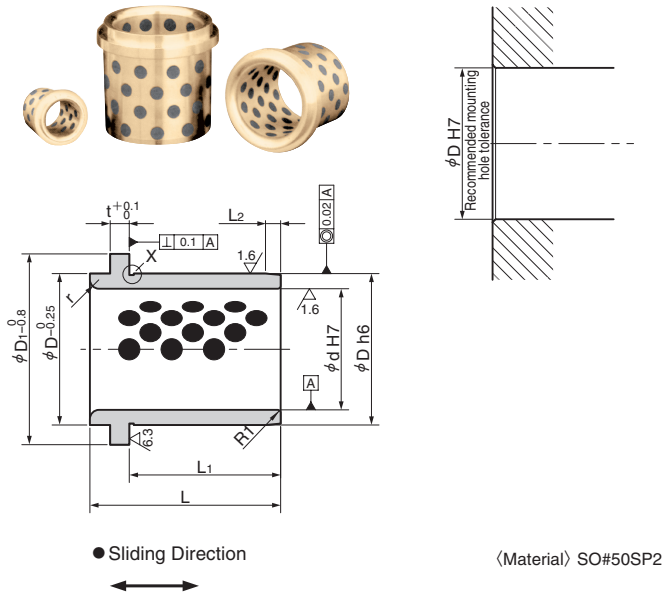

VDI-KL (Clamp) (DIN9832)

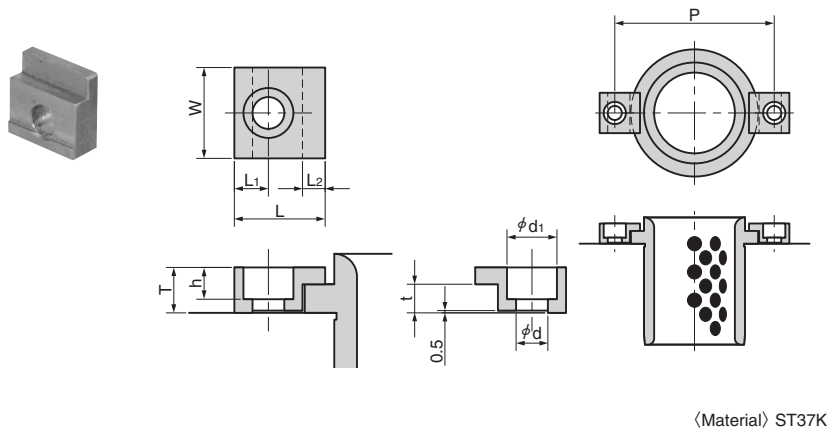

Catalog No. (Type)	d	H7	D	h6	L	D <sub>1</sub>	L <sub>1</sub>	L <sub>2</sub>	t	r	X (DIN 509)
9834-025 (31)	25	<sup>+0.021</sup> <sub>0</sub>	32		40	40	30	3			
9834-032 (32)	32		40	<sup>0</sup> <sub>-0.016</sub>	50	50	38	4	6.3	3	F0.6x0.3
9834-040 (33)	40	<sup>+0.025</sup> <sub>0</sub>	50		63	63	48	5			
9834-050 (34)	50		63	<sup>0</sup> <sub>-0.019</sub>	71	71	54	6.3		5	
9834-063 (35)	63		80	<sup>0</sup> <sub>-0.022</sub>	80	90	61	8		6	
9834-080 (36)	80	<sup>+0.030</sup> <sub>0</sub>	100	<sup>0</sup> <sub>-0.025</sub>	100	112	78	10		8	
9834-100 (37)	100		125	<sup>0</sup> <sub>-0.025</sub>	125	140	104	12.5	10	10	F1.0x0.4
9834-125 (38)	125	<sup>+0.040</sup> <sub>0</sub>	160	<sup>0</sup> <sub>-0.029</sub>	160	180	16	16			
9834-160 (40)	160		200	<sup>0</sup> <sub>-0.029</sub>	200	220	168	16		18	



Catalog No.  
9834-063

● Operating conditions

Allowable maximum surface pressure P daN/cm <sup>2</sup>	Allowable maximum speed V m/min	Allowable maximum PV value daN/cm <sup>2</sup> · m/min	Operating temperature °C
1000	15	2000	-150~300

● Mating material condition  
Hardness : min HRC35  
Surface roughness  
Ra 0.8 μm or less

Catalog No. (Type)	W	L	T	L <sub>1</sub>	L <sub>2</sub>	t	d	d <sub>1</sub>	h	Applicable post diameter
VDI-KL- 6 ( 6)	20	20	10	7.5	5	6.3	7	11	7	φ25~φ50
VDI-KL-10 (10)	32	32	16	11	10	10	11.5	17.5	11.5	φ63~φ160



Catalog No.  
VDI-KL-10

● Clamp mounting hole circle

Bushing Hole Diameter	P
25	58
32	66
40	79
50	89
63	123
80	143
100	168
125	203
160	243