

Center Key Guide

NAAMS Standard

SNG41 (Steel Type) Series

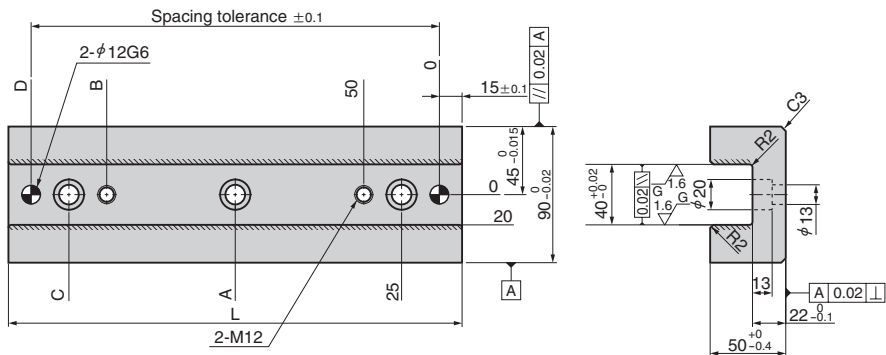

(Material) 1045 (S45C)
 (Hardness) HRC55~60
 Hatched area to be
 Induction Hardened

Catalog No.		No. of Mounting Bolt	A	B	C	D	L	NAAMS Code
Series Name	No.							
SNG41	9020	2	—	120	145	170	200	G419020
	9030	3	135	220	245	270	300	G419030

SNG41 Series is made to order.



Catalog No.

Series Name No.

SNG41 9020 (SNG419020)