

Cam Slide Guide

V-Shaped Guide Type

NAAMS Standard

SNG99 (U Block)

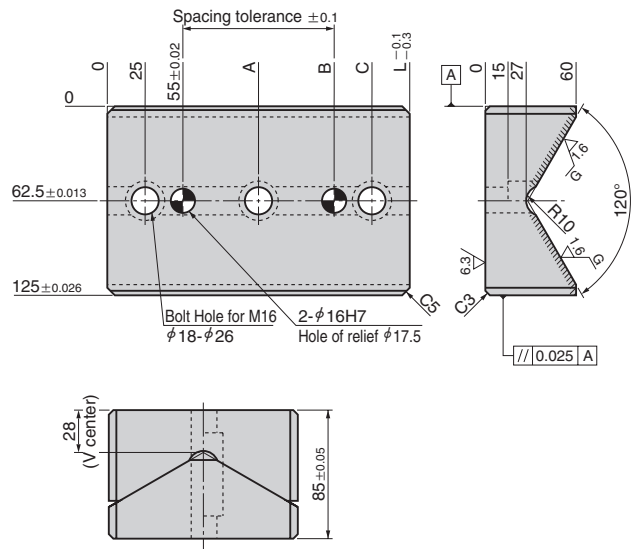

(Material) 1045 (S45C)
 (Hardness) HRC55~60
 Hatched area to be Induction Hardened

Catalog No.		No. of Holes	L	A	B	C	NAAMS Code
Series Name	No.						
SNG99	1215	2	150	—	100	125	G991215
	1220		200	—	150	175	G991220
	1225	3	250	125	200	225	G991225
	1230		300	150	250	275	G991230

SNG99 Series is made to order.



Catalog No.

Series Name No.

SNG99 1225 (SNG991225)

SNG100 (V Block)

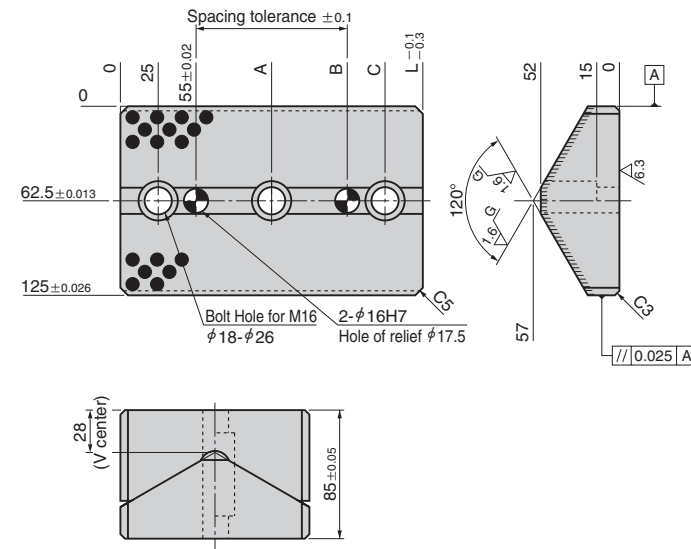
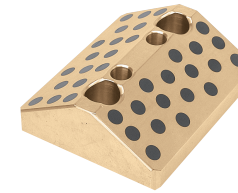

(Material) SO#50SP2

Catalog No.		No. of Holes	L	A	B	C	NAAMS Code
Series Name	No.						
SNG100	1215	2	150	—	100	125	G1001215
	1220		200	—	150	175	G1001220
	1225	3	250	125	200	225	G1001225
	1230		300	150	250	275	G1001230

SNG100 Series is made to order.



Catalog No.

Series Name No.

SNG100 1225 (SNG1001225)