

# Cam Slide Guide

## V-Shaped Guide Type

NAAMS Standard

SNG98 (U Block)

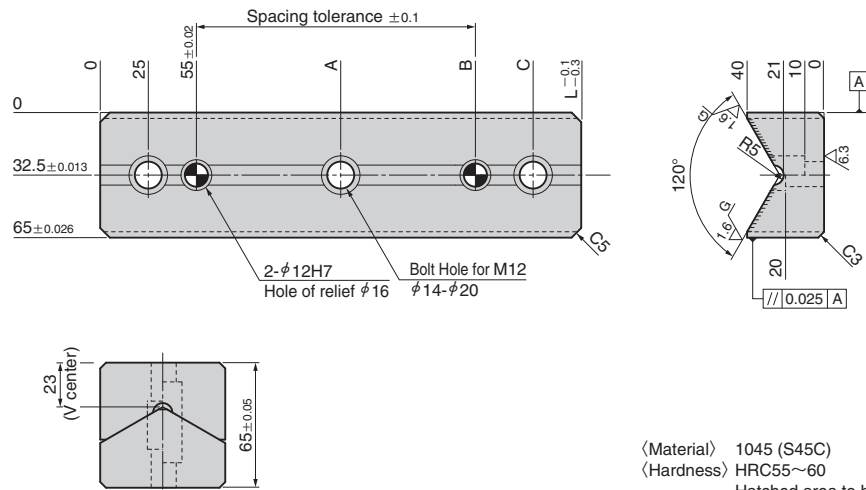

(Material) 1045 (S45C)  
(Hardness) HRC55~60  
Hatched area to be Induction Hardened

Catalog No.		No. of Holes	L	A	B	C	NAAMS Code
Series Name	No.						
SNG98	6515	2	150	—	100	125	G986515
	6520		200	—	150	175	G986520
	6525	3	250	125	200	225	G986525
	6530		300	150	250	275	G986530

SNG98 Series is made to order.

 **Order**

Catalog No.

Series Name  No.

**SNG98 6520** (SNG986520)

SNG97 (V Block)

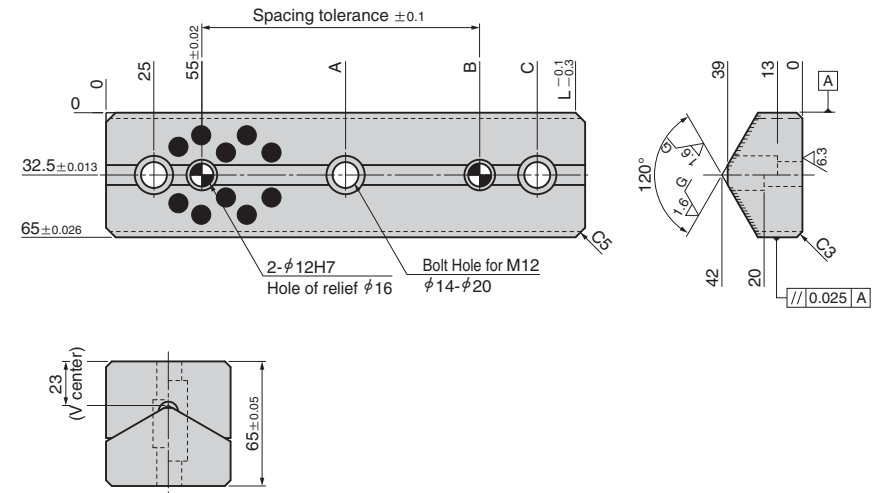

(Material) SO#50SP2

Catalog No.		No. of Holes	L	A	B	C	NAAMS Code
Series Name	No.						
SNG97	6515	2	150	—	100	125	G976515
	6520		200	—	150	175	G976520
	6525	3	250	125	200	225	G976525
	6530		300	150	250	275	G976530

SNG97 Series is made to order.

 **Order**

Catalog No.

Series Name  No.

**SNG97 6520** (SNG976520)