

# Cam Slide Guide

NAAMS Standard

SNG01 (W = 45 mm) Series

SNG02 (W = 60 mm) Series

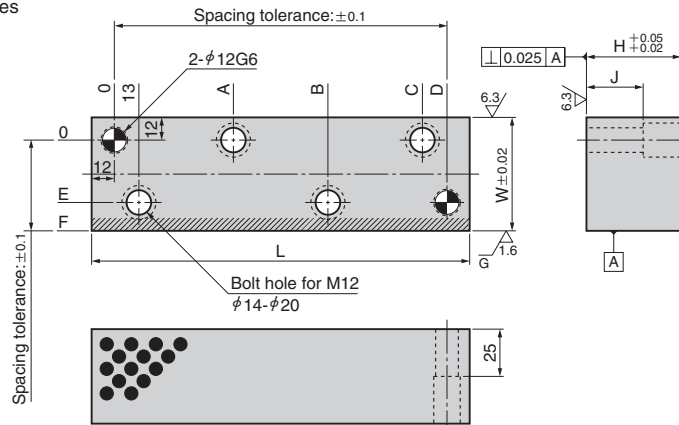

(Material) SO#50S45C  
(Hardness) HRC40 or more  
Hatched area to be Induction Hardened

● W=45mmType

Catalog No.		No. of Holes	W	L	A	B	C	D	E	F	H	J	NAAMS Code
Series Name	No.												
SNG01	4007	2	45	75	—	—	38	51	18	33	45	25	G014007
	4010			100	—	—	63	76					G014010
	4012	3	125	—	50.5	88	101	G014012					
	4015		150	—	63	113	126	G014015					
	4017	4	175	—	75.5	138	151	G014017					
	4020		200	63	113	163	176	G014020					
	4022	4	225	73	128	188	201	G014022					
	4025		250	83	153	213	226	G014025					
	4507	2	75	—	—	38	51	G014507					
	4510		100	—	—	63	76	G014510					
	4512	3	125	—	50.5	88	101	G014512					
	4515		150	—	63	113	126	G014515					
	4517	4	175	—	75.5	138	151	G014517					
	4520		200	63	113	163	176	G014520					
	4522	4	225	73	128	188	201	G014522					
	4525		250	83	153	213	226	G014525					
	5007	2	75	—	—	38	51	G015007					
	5010		100	—	—	63	76	G015010					
	5012	3	125	—	50.5	88	101	G015012					
	5015		150	—	63	113	126	G015015					
5017	4	175	—	75.5	138	151	G015017						
5020		200	63	113	163	176	G015020						
5022	4	225	73	128	188	201	G015022						
5025		250	83	153	213	226	G015025						



Catalog No. \_\_\_\_\_  
Series Name No. \_\_\_\_\_

SNG01 7522 (SNG017522)

Catalog No.		No. of Holes	W	L	A	B	C	D	E	F	H	J	NAAMS Code
Series Name	No.												
SNG01	6007	2	45	75	—	—	38	51	18	33	70	30	G016007
	6010			100	—	—	63	76					G016010
	6012	3	125	—	50.5	88	101	G016012					
	6015		150	—	63	113	126	G016015					
	6017	4	175	—	75.5	138	151	G016017					
	6020		200	63	113	163	176	G016020					
	6022	4	225	73	128	188	201	G016022					
	6025		250	83	153	213	226	G016025					
	7507	2	75	—	—	38	51	G017507					
	7510		100	—	—	63	76	G017510					
	7512	3	125	—	50.5	88	101	G017512					
	7515		150	—	63	113	126	G017515					
	7517	4	175	—	75.5	138	151	G017517					
	7520		200	63	113	163	176	G017520					
	7522	4	225	73	128	188	201	G017522					
	7525		250	83	153	213	226	G017525					

● W=60mmType

Catalog No.		No. of Holes	W	L	A	B	C	D	E	F	H	J	NAAMS Code
Series Name	No.												
SNG02	5007	2	60	75	—	—	38	51	33	48	80	30	G025007
	5010			100	—	—	63	76					G025010
	5012	3	125	—	50.5	88	101	G025012					
	5015		150	—	63	113	126	G025015					
	5017	4	175	—	75.5	138	151	G025017					
	5020		200	63	113	163	176	G025020					
	5022	4	225	73	128	188	201	G025022					
	5025		250	83	153	213	226	G025025					
	6007	2	75	—	—	38	51	G026007					
	6010		100	—	—	63	76	G026010					
	6012	3	125	—	50.5	88	101	G026012					
	6015		150	—	63	113	126	G026015					
	6017	4	175	—	75.5	138	151	G026017					
	6020		200	63	113	163	176	G026020					
	6022	4	225	73	128	188	201	G026022					
	6025		250	83	153	213	226	G026025					
	8007	2	75	—	—	38	51	G028007					
	8010		100	—	—	63	76	G028010					
	8012	3	125	—	50.5	88	101	G028012					
	8015		150	—	63	113	126	G028015					
8017	4	175	—	75.5	138	151	G028017						
8020		200	63	113	163	176	G028020						
8022	4	225	73	128	188	201	G028022						
8025		250	83	153	213	226	G028025						
0007	2	75	—	—	38	51	G020007						
0010		100	—	—	63	76	G020010						
0012	3	125	—	50.5	88	101	G020012						
0015		150	—	63	113	126	G020015						
0017	4	175	—	75.5	138	151	G020017						
0020		200	63	113	163	176	G020020						
0022	4	225	73	128	188	201	G020022						
0025		250	83	153	213	226	G020025						

SNG01, 02 Series are made to order.