

Pad Guide Block

NAAMS Standard

SNG11 Series

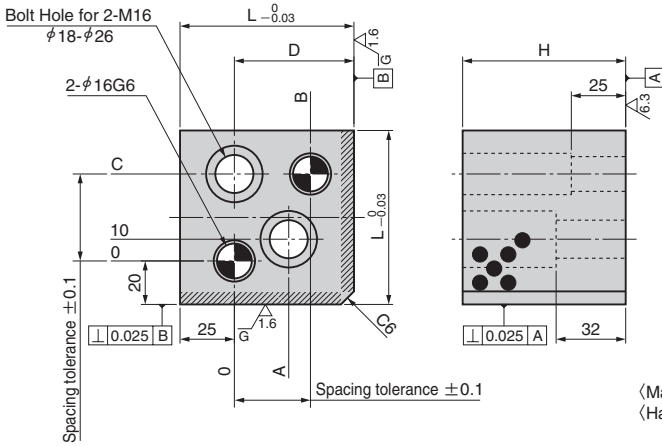
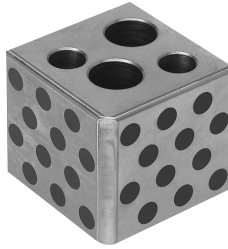

(Material) SO#50S45C
 (Hardness) HRC40 or more
 Hatched area to be Induction Hardened

Catalog No.		H	A	B	C	D	L	NAAMS Code
Series Name	No.							
SNG11	8007	75						G118007
	8010	100	25	35	40	55	80	G118010
	8012	125						G118012
	9507	75						G119507
	9510	100	40	50	55	70	95	G119510
	9512	125						G119512
	1207	75						G111207
	1210	100	65	75	80	95	120	G111210
	1212	125						G111212

SNG11 Series is made to order.



Catalog No.	
Series Name	No.

SNG11 1212 (SNG111212)

NAAMS Standard