

NEW

PSCXG [Overview]

Roller Cam Unit

For Pierce

Product Information

- Mount face widths 55, 80, 100, and 120 mm.
- Working angles from -20° ~ 50° in 5° increments.
- Gas spring type acc. to VDI 3003.
- Low maintenance by minimizing the number of parts.
- Suitable drivers available.
- Optional positive return follower.

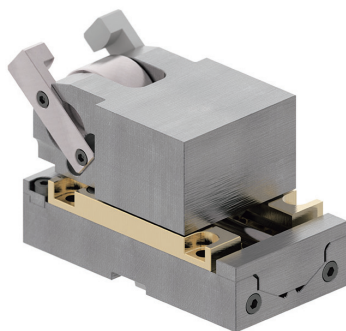

Mount face		Working Angle	Travel*1	Working Force kN 1,000,000 strokes
W	H			
55	55	-20° ~ 50° (5° increments)	35, (32)	32.0
80	70		40, (37)	65.0
100	65		50, (47)	85.0
120	75		50, (47)	140.0
			80, (77)	

*1 The max. usable travel is nominal travel -3mm

Option

- Driver Type (-DH20 ~ -D00 ~ -DL50)

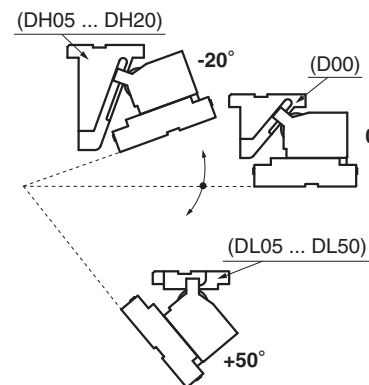

Working Angle	Option Code
-20	DH20
-15	DH15
-10	DH10
-05	DH05
00	D00
05	DL05
10	DL10
15	DL15
20	DL20
25	DL25
30	DL30
35	DL35
40	DL40
45	DL45
50	DL50

Option

- Key Specification (-K)

55 Width
(A M6 Bolt is included.)

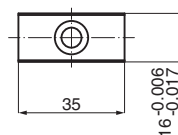

80 Width
(A M6 Bolt is included.)

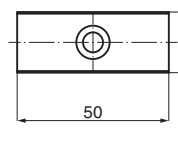

100,120 Width
(A M8 Bolt is included.)

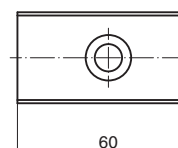

Option

- Positive Return Follower (-PR)

55 Width

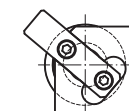

80 Width

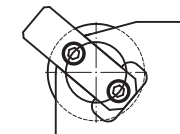

100 Width

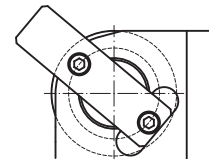

120 Width

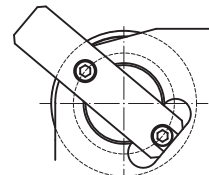

Product Information

■PSCXG55·80 Assembly Instructions

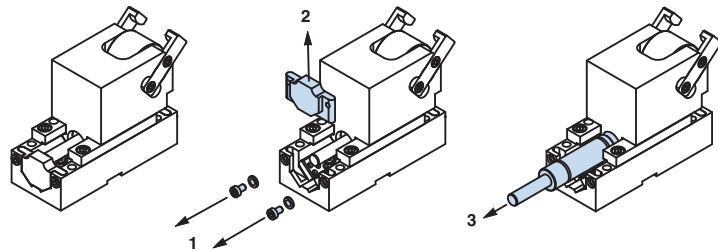

●Disassembly instructions of Gas Spring from the front

- 1) Remove Hexagon Socket Head Bolts.
- 2) Pull out Stopper Plate F.
- 3) Remove Gas Spring to the front.

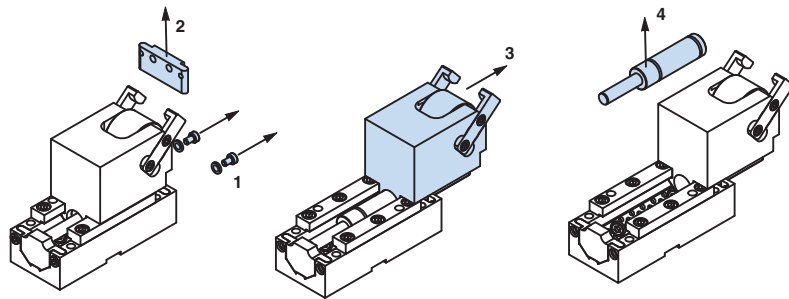

●Disassembly

- 1) Remove Hexagon Socket Head Bolts.
- 2) Pull out Stopper Plate R.
- 3) Remove Cam Slider to the rear.
- 4) Remove Gas Spring.

●Assembly

Assembly is the reverse procedure of disassembly.

- Ensure that all parts are clean, particularly the sliding components to which a small amount of lubricant is applied and is then placed in position.
- Take care that the respective tolerances are observed when assembling Cam Slider and Cam Holder, which also should be identified by the same serial number.
- Make sure that all bolts are tightened to the recommended torque after assembly and disassembly.

⚠ Gas Spring

Please contact your local sales representative if you prefer to use a gas spring not specified in our catalog. For use and maintenance of gas spring, please contact the manufacturer directly.

■PSCXG100·120 Assembly Instructions

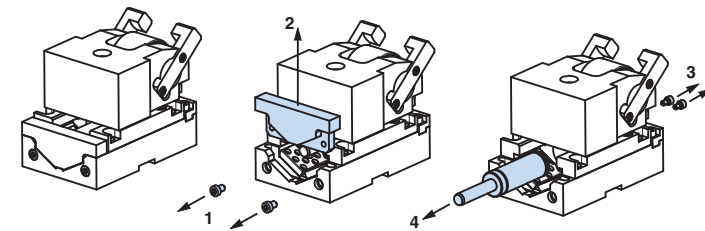

●Disassembly instructions of Gas Spring from the front

- 1) Remove Hexagon Socket Head Bolts.
- 2) Pull out Stopper Plate F.
- 3) Loosen Hexagon Socket Head Bolts of Gas Spring.
- 4) Remove Gas Spring to the front.

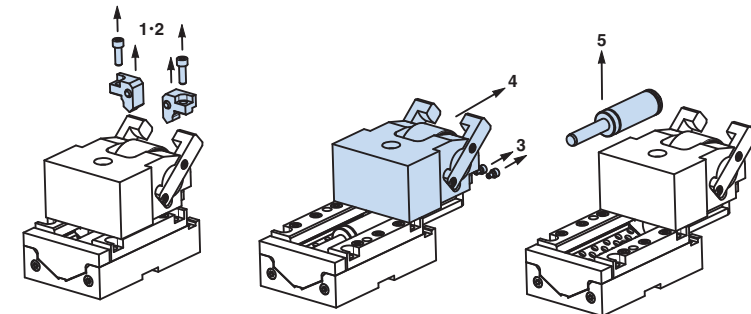

●Disassembly

- 1) Remove Hexagon Socket Head Bolts.
- 2) Pull out Stopper Plate R.
- 3) Loosen Hexagon Socket Head Bolts of Gas Spring.
- 4) Remove Cam Slider to the rear.
- 5) Remove Gas Spring.

●Assembly

Assembly is the reverse procedure of disassembly.

- Ensure that all parts are clean, particularly the sliding components to which a small amount of lubricant is applied and is then placed in position.
- Take care that the respective tolerances are observed when assembling Cam Slider and Cam Holder, which also should be identified by the same serial number.
- Make sure that all bolts are tightened to the recommended torque after assembly and disassembly.

⚠ Gas Spring

Please contact your local sales representative if you prefer to use a gas spring not specified in our catalog. For use and maintenance of gas spring, please contact the manufacturer directly.

NEW

PSCXG Roller Cam Unit

For Pierce

Die Mounted Cam Unit

PSCXG120-50
PSCXG120-80

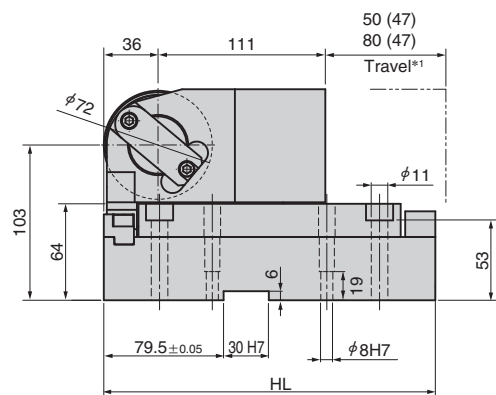
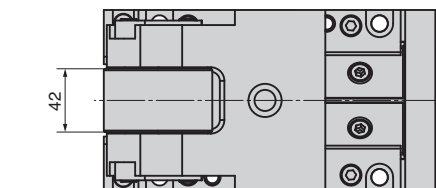

*1 The max. usable travel is nominal travel -3mm

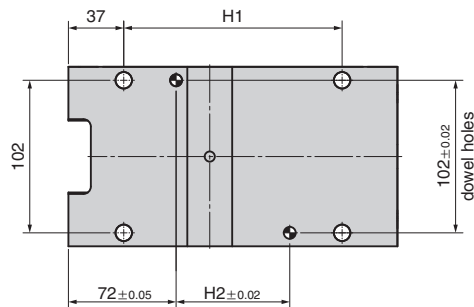
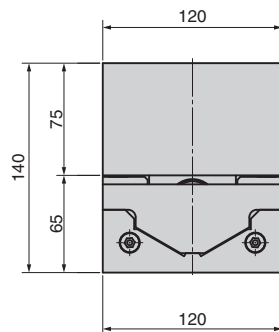

Working Force kN	Spring Force kN		Return Force kN	Catalog No.	W	Travel S	Driver Type Working Angle	Spring Type PS
		Final Load						
140.0		4.03		PSCXG	120	50	DH20 ~ D00 ~ DL50	GK
		3.94						GD
		4.23						GSS
		4.03						GH
		—	4.1					ND
		4.15				-20° ~ 50°		
		4.05				(5° increments)	GK	
		4.47				GD		
		4.15				GSS		
		—				GH		
					80			NGP

ND: Without Driver
GK: Gas Spring (KALLER) GD: Gas Spring (DADCO) GSS: Gas Spring (Special Springs) GH: Gas Spring (Hyson)
NGP: Without Gas Spring Parts for spring assembly are included.



Catalog No.	W	S	Driver Type	PS	Option
PSCXG	120	50	ND	GK	
PSCXG	120	80	D00	GK	
PSCXG	120	50	DH05	NGP	PR
PSCXG	120	80	DL30	GSS	NF - K - PR



Option Code	Specification
NF	Nitrogen gas not charged.
K	Key attached.
PR	Positive Return Follower attached.

Overall Dimensions

S	HL	H1	H2
50, (47)	190	116	46
80, (77)	220	146	76

Spring Specification

● Travel 50 mm

No.	PS	Spring Model	Qty	Remark
13	GK	X350-063-15MPa	1	Gas Spring (KALLER)
	GD	U.0400.063-15MPa	1	Gas Spring (DADCO)
	GSS	RV350-063-B-15MPa	1	Gas Spring (Special Springs)
	GH	T3-350X63-15MPa	1	Gas Spring (Hyson)

● Travel 80 mm

No.	PS	Spring Model	Qty	Remark
13	GK	X350-080-13.9MPa	1	Gas Spring (KALLER)
	GD	U.0400.080-13.9MPa	1	Gas Spring (DADCO)
	GSS	RV350-080-B-13.9MPa	1	Gas Spring (Special Springs)
	GH	T3-350X80-13.9MPa	1	Gas Spring (Hyson)

Refer to page 1125 for Table of Components.

Die Mounted Cam Unit

Working Force Distribution Diagram

The working forces indicated in the mount face distribution diagram are reached by putting the tooling center of gravity within each area for the following pictures.
Working force (kN) allowed for up to 1,000,000 strokes.

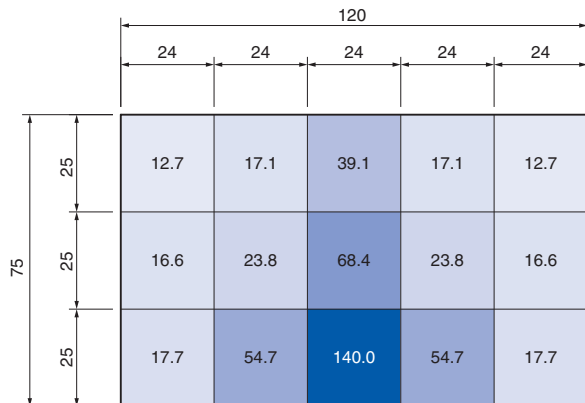

Weight

Travel S	Total Weight kg	Cam Slider Weight kg
50	17.6	9.9
80	18.8	

Driver Options

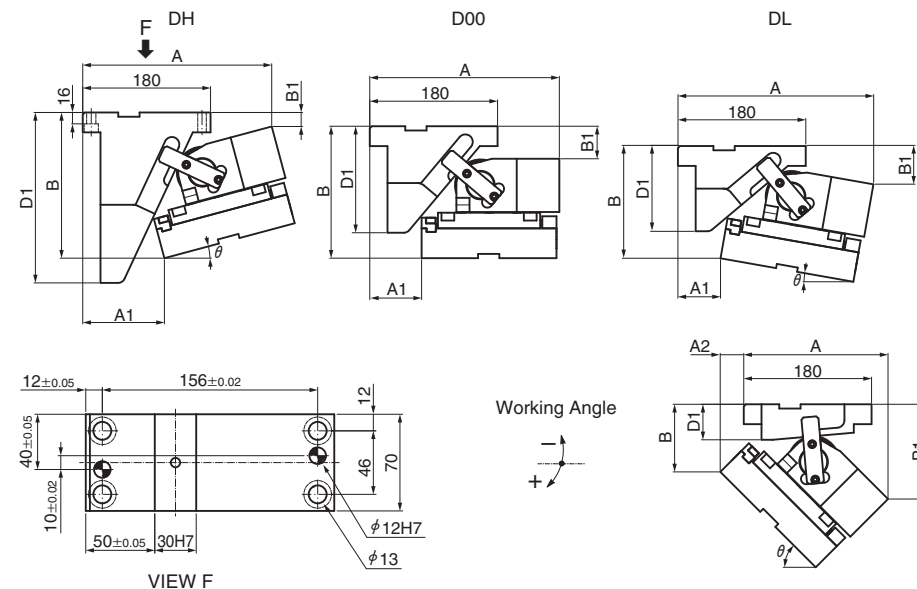

● Travel 50 mm

Working Angle θ	-20	-15	-10	-5	0	5	10	15	20	25	30	35	40	45	50
Driver Type	DH20	DH15	DH10	DH05	D00	DL05	DL10	DL15	DL20	DL25	DL30	DL35	DL40	DL45	DL50
D1	290	240	210	170	150	140	120	110	90	80	70	60	55	50	58
A	259.42	266.16	261.74	266.06	267.00	260.46	275.36	268.62	260.18	244.99	238.01	229.22	218.60	203.17	198.95
A1	125	115	95	85	75	55	60	45	35	25	10	0	—	—	—
A2	—	—	—	—	—	—	—	—	—	—	—	—	10	25	25
B	223.36	205.18	209.17	195.31	185.81	182.63	158.14	152.18	144.77	138.23	125.52	112.20	103.08	95.22	96.63
B1	25.45	19.74	37.61	38.94	45.81	60.07	53.95	67.16	79.57	93.34	101.28	108.79	120.53	133.41	155.25

● Travel 80 mm

Working Angle θ	-20	-15	-10	-5	0	5	10	15	20	25	30	35	40	45	50
Driver Type	DH20	DH15	DH10	DH05	D00	DL05	DL10	DL15	DL20	DL25	DL30	DL35	DL40	DL45	DL50
D1	290	240	210	170	150	140	120	110	90	80	70	60	55	50	58
A	262.61	265.13	266.29	275.95	277.00	275.35	274.91	267.60	268.37	257.18	243.99	238.79	221.58	217.39	206.23
A1	100	85	70	65	53	40	30	15	10	—	—	—	—	—	—
A2	—	—	—	—	—	—	—	—	—	5	20	25	40	40	45
B	224.85	215.13	206.51	183.81	173.90	165.12	153.31	145.13	129.78	119.87	108.34	92.43	83.27	72.76	73.64
B1	16.68	21.93	29.74	24.82	33.89	45.18	54.33	67.87	74.84	87.65	99.09	106.23	120.01	132.16	155.25

NEW

PSCXG

Roller Cam Unit

For Pierce

Die Mounted Cam Unit

■ Rear Removal Space

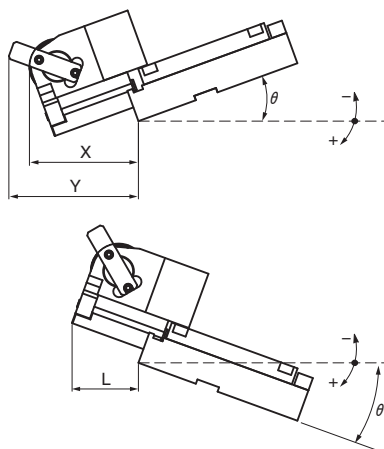

Working Angle θ	X	Y	L
-20	142	168	—
-15	135	160	—
-10	128	151	—
-05	120	141	—
00	101	119	—
05	—	107	97
10	—	94	94
15	—	—	90
20	—	—	86
25	—	—	81
30	—	—	76
35	—	—	70
40	—	—	63
45	—	—	56
50	—	—	49

■ Cam Diagram

● Travel 50 mm

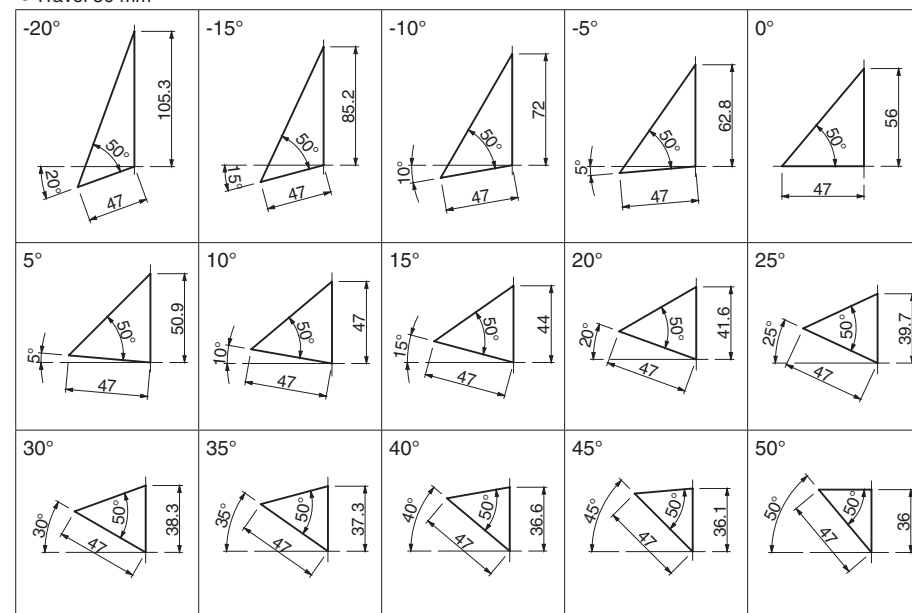

● Travel 80 mm

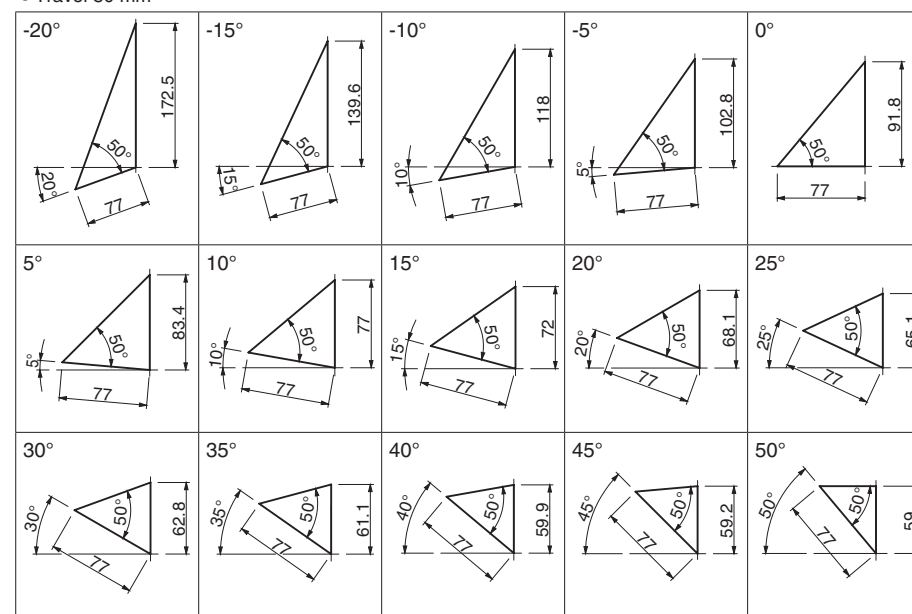

NEW

PSCXG [Table of Components]

Roller Cam Unit

For Pierce

Die Mounted Cam Unit

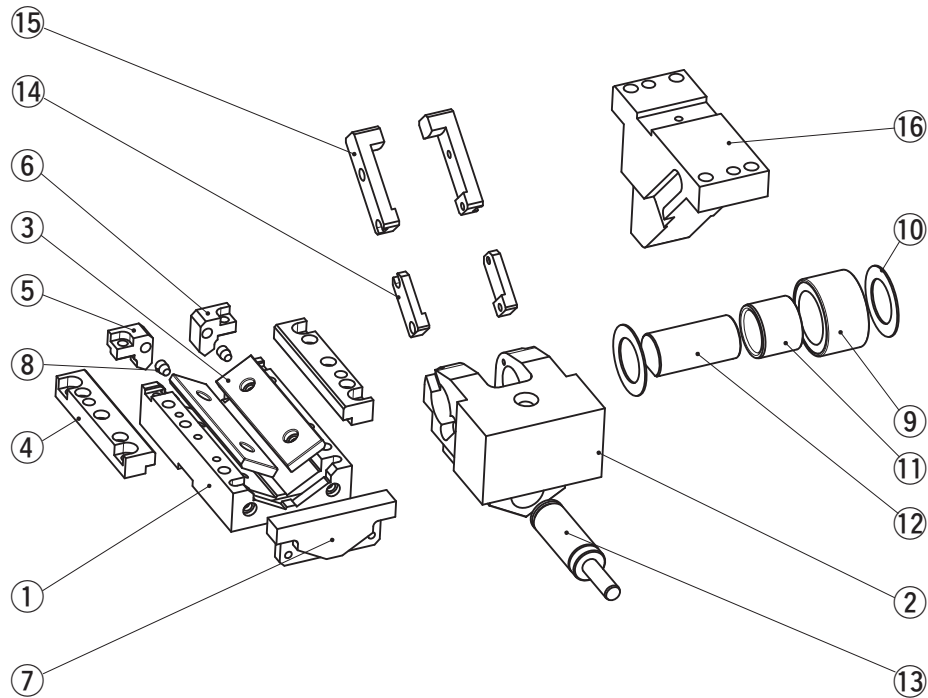
PSCXG120

No.	Description	Qty	Material and Remark
1	Holder	1	Steel
2	Slider	1	Steel
3	Slide Plate	2	Bronze with graphite
4	Upper Plate	2	Bronze with graphite
5	Stopper Plate R A	1	Steel
6	Stopper Plate R B	2	Steel
7	Stopper Plate F	1	Steel
8	Stopper	2	—
9	Roller	1	Steel
10	Washer, drystar	2	—
11	Bush	1	Bronze with graphite
12	Pin	1	Steel
13	Gas Spring	1	Refer to the Spring Specification.
14	Stop Block	2	Steel
15	Positive Return	2	Steel, optional
16	Driver	1	Steel, optional

Bolts, nuts, dowels, and washers for assembly are not indicated.