

UCMSL [Overview]

Large Type

Product Information

- Mount face widths from 500 to 1000 mm in 100 mm increments.
- Working angles from 0° to 60° in 5° increments.
- Gas Spring is removable from the rear without disassembling.
- 1600 mm wide or smaller available on demand.
- 65°, 70°, 75° upon request.

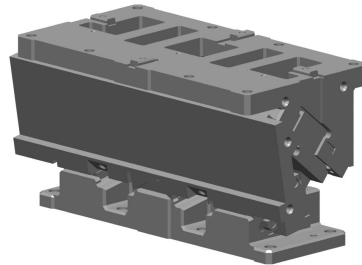

Mount face		Working Angle	Travel	Working Force kN (tonf)	Spring Force N (kgf)
W	H				
500 600	180	00	38.6	313.6 (32.0)	18682.0 (1906.3)
		05	42.6		
		10	46.7		
		15	50.9		
		20	55.3		
		25	60.0		
		30	65.1		
		35	70.8		
		40	77.1		
		45	84.5		
		50	93.3		
		55	104.6		
700 800	180	60	120.0	470.4 (48.0)	28023.0 (2859.5)
		00	38.6		
		05	42.6		
		10	46.7		
		15	50.9		
		20	55.3		
		25	60.0		
		30	65.1		
		35	70.8		
		40	77.1		
		45	84.5		
		50	93.3		
55	104.6				
900 1000	180	60	120.0	627.2 (64.0)	37364.0 (3812.7)
		00	38.6		
		05	42.6		
		10	46.7		
		15	50.9		
		20	55.3		
		25	60.0		
		30	65.1		
		35	70.8		
		40	77.1		
		45	84.6		
		50	93.3		
55	104.6				
60	120.0				

For Pierce

For Trim

For Flange

UCMSL500/UCMSL600 Assembly Instructions

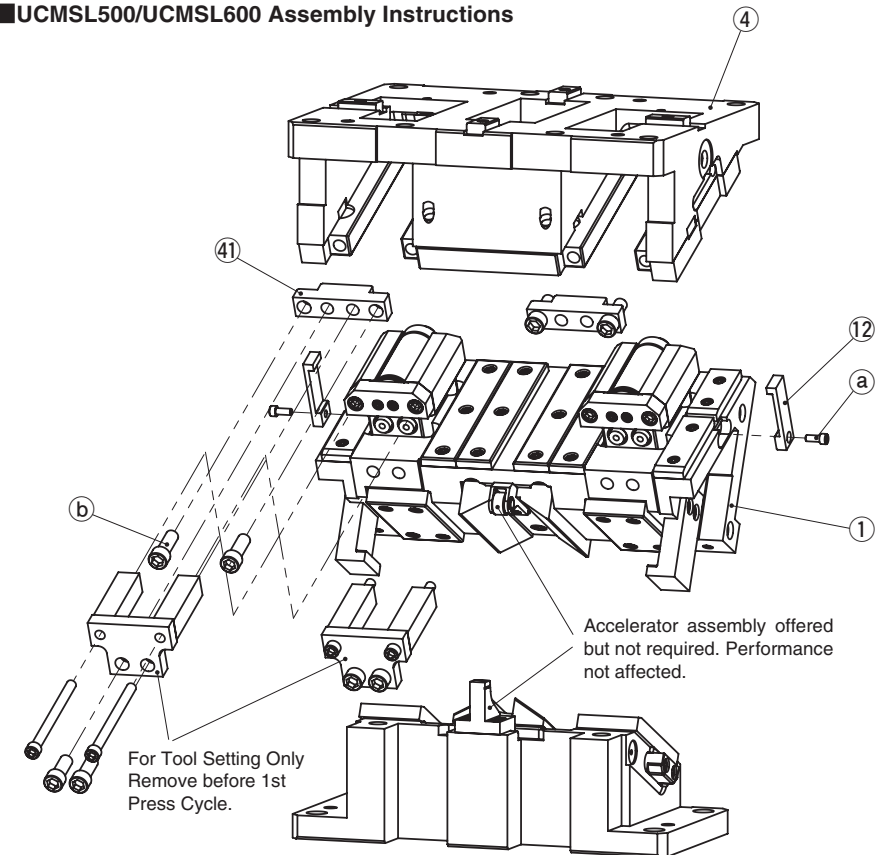

Disassembly

- 1) Remove Hexagon Socket Head Bolts (Ⓐ), to pull out Safety Plate (Ⓔ).
- 2) Remove Hexagon Socket Head Bolts (Ⓒ), to pull out Stopper Plate (Ⓓ).
- 3) Pull out and remove Cam Slider (Ⓚ) from Cam Holder (Ⓖ) to the rear.

Assembly

Assembly is the reverse procedure of disassembly.

- Ensure that all parts are clean, particularly the sliding components to which a small amount of lubricant is applied and is then placed in position.
- Take care that the respective tolerances are observed when assembling Cam Slider and Cam Holder, which also should be identified by the same serial number.
- Make sure that all bolts are tighten to the recommended torque after assembly and disassembly.

⚠ Gas Spring

Please contact your local sales representative if you prefer to use a gas spring not specified in our catalog. For use and maintenance of gas spring, please contact the manufacturer directly.

UCMSL [Overview]

Large Type

Product Information

For Pierce

For Trim

For Flange

UCMSL700/UCMSL800 Assembly Instructions

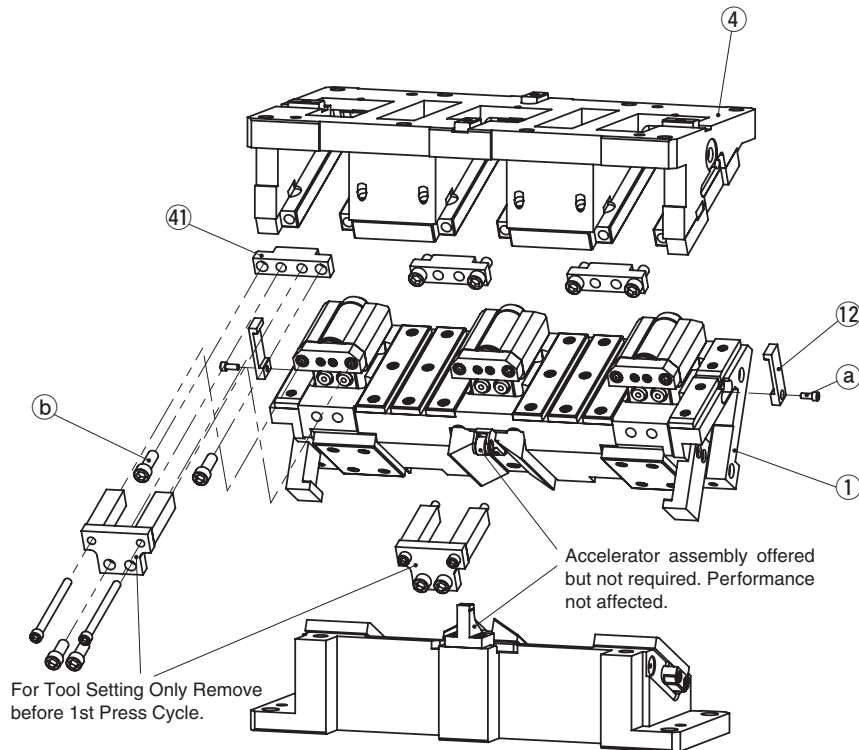

Disassembly

- 1) Remove Hexagon Socket Head Bolts (Ⓒ), to pull out Safety Plate (Ⓙ).
- 2) Remove Hexagon Socket Head Bolts (Ⓓ), to pull out Stopper Plate (Ⓖ).
- 3) Pull out and remove Cam Slider (Ⓛ) from Cam Holder (Ⓜ) to the rear.

Assembly

Assembly is the reverse procedure of disassembly.

- Ensure that all parts are clean, particularly the sliding components to which a small amount of lubricant is applied and is then placed in position.
- Take care that the respective tolerances are observed when assembling Cam Slider and Cam Holder, which also should be identified by the same serial number.
- Make sure that all bolts are tighten to the recommended torque after assembly and disassembly.

⚠ Gas Spring

Please contact your local sales representative if you prefer to use a gas spring not specified in our catalog. For use and maintenance of gas spring, please contact the manufacturer directly.

UCMSL900/UCMSL1000 Assembly Instructions

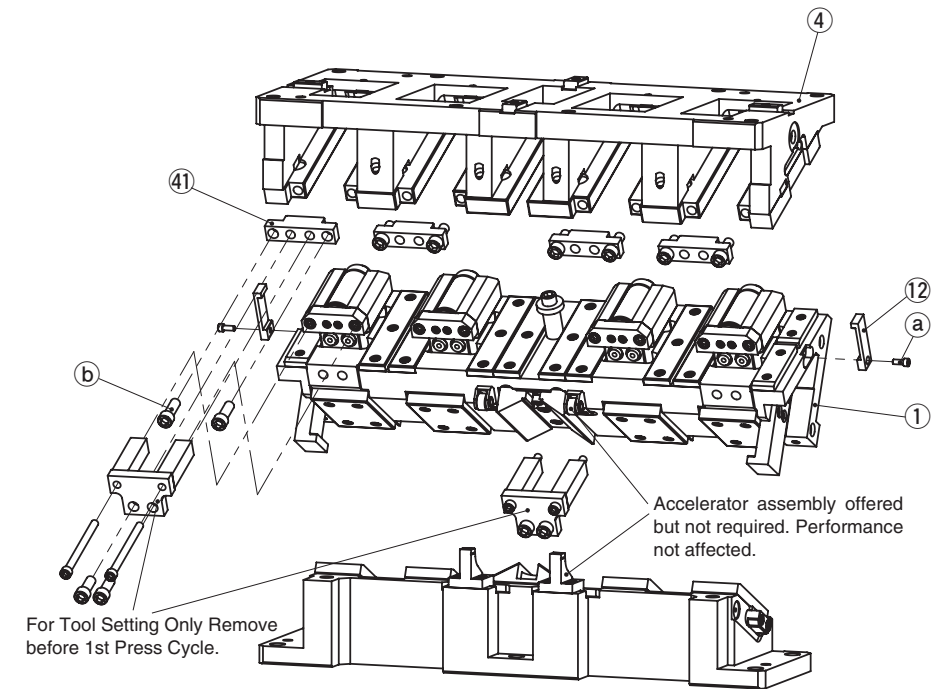

Disassembly

- 1) Remove Hexagon Socket Head Bolts (Ⓒ), to pull out Safety Plate (Ⓙ).
- 2) Remove Hexagon Socket Head Bolts (Ⓓ), to pull out Stopper Plate (Ⓖ).
- 3) Pull out and remove Cam Slider (Ⓛ) from Cam Holder (Ⓜ) to the rear.

Assembly

Assembly is the reverse procedure of disassembly.

- Ensure that all parts are clean, particularly the sliding components to which a small amount of lubricant is applied and is then placed in position.
- Take care that the respective tolerances are observed when assembling Cam Slider and Cam Holder, which also should be identified by the same serial number.
- Make sure that all bolts are tighten to the recommended torque after assembly and disassembly.

⚠ Gas Spring

Please contact your local sales representative if you prefer to use a gas spring not specified in our catalog. For use and maintenance of gas spring, please contact the manufacturer directly.

UCMSL

Large Type

For Pierce For Trim For Flange

Aerial Cam Unit

UCMSL500-00/UCMSL600-00

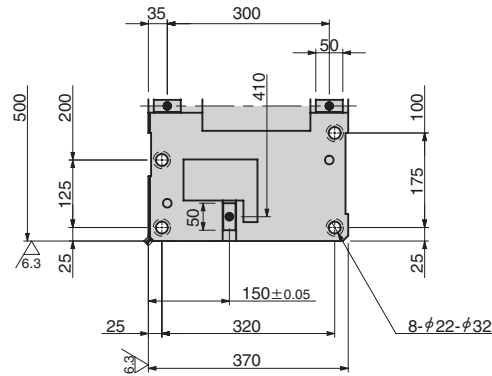

● Cam Diagram

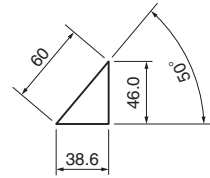

The Cam Diagram shows no Roller Bracket assemblies or Accelerators. If these items are needed, please contact local sales representative.

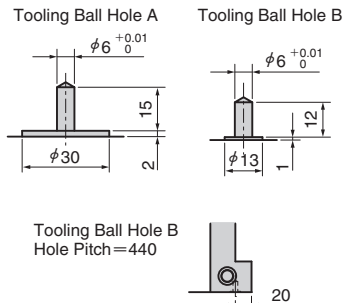
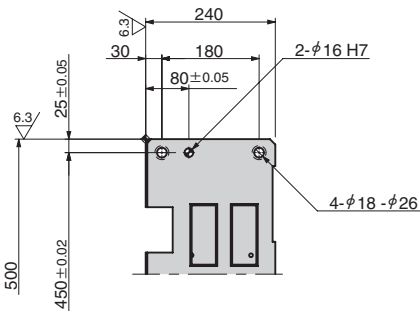
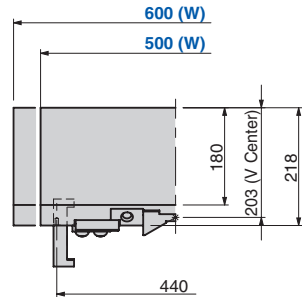
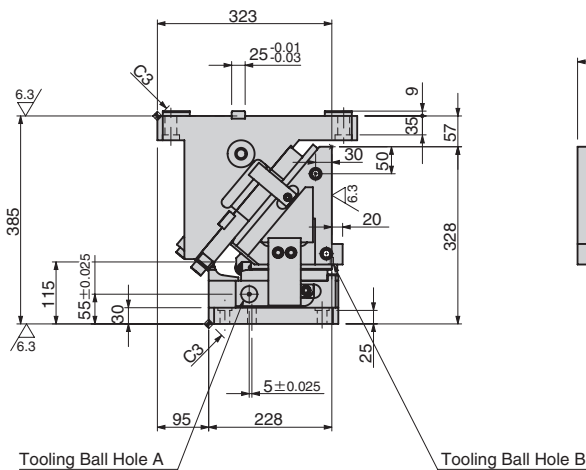

Travel S	Working Force kN (tonf)	Spring Force N (kgf)		Return Force N (kgf)	Catalog No.	W	θ	Spring Type PS
		Initial Load	Final Load					
38.6	313.6 (32.0)	—	18682.0 (1906.3)	25575 (2609.7)	UCMSL	500 600	00	GK NGK GD NGD GS NGS

GK: Gas Spring (KALLER) GD: Gas Spring (DADCO) GS: Gas Spring (SDT)
NGK/NGD/NGS: Without Gas Spring Parts for spring assembly are included.



Catalog No.	W	θ	PS	Option
UCMSL	500	—	00	— GK
UCMSL	600	—	00	— NGK
UCMSL	500	—	00	— GK — NF



Option Code	Specification
NF	Nitrogen gas not charged.

Spring Specification

No.	PS	Spring Model	Qty	Remark
15	GK	K750-80-TD	2	Gas Spring (KALLER)
	GD	L.750.075.TO.140	2	Gas Spring (DADCO)
	GS	SM0750.75	2	Gas Spring (SDT)

Weight

W	Cam Slider Weight kg	Total Weight kg
500	106.1	265.6
600	112.9	272.4

Rear Removal Space

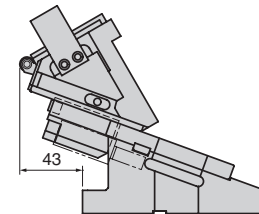

Refer to page 869 for Table of Components.

UCMSL Large Type

Aerial Cam Unit

For Pierce

For Trim

For Flange

UCMSL500-05/UCMSL600-05



● Cam Diagram

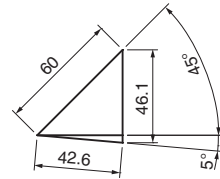
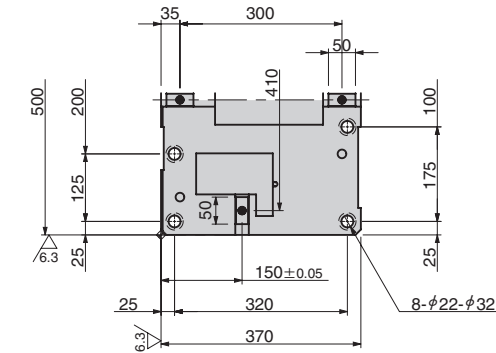

The Cam Diagram shows no Roller Bracket assemblies or Accelerators. If these items are needed, please contact local sales representative.

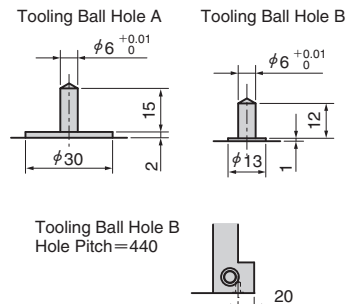
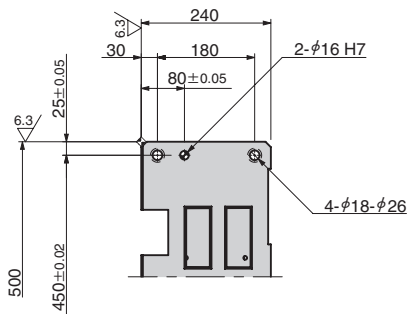
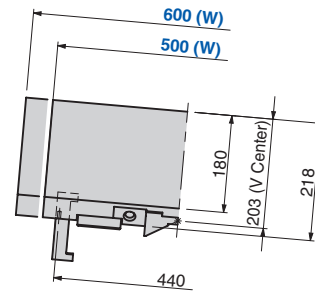
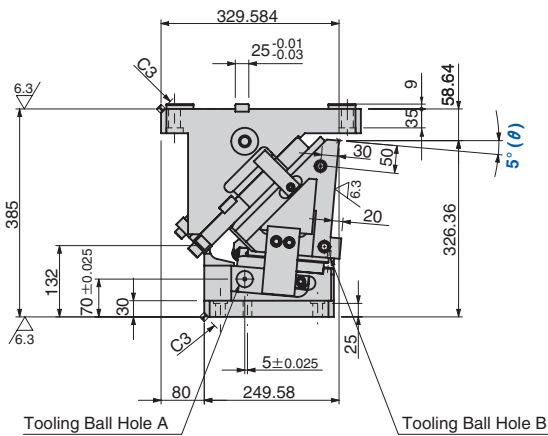

Travel S	Working Force kN (tonf)	Spring Force N (kgf)		Return Force N (kgf)	Catalog No.	W	θ	Spring Type PS
		Initial Load	Final Load					
42.6	313.6 (32.0)	—	18682.0 (1906.3)	25481 (2600.1)	UCMSL	500 600	05	GK NGK GD NGD GS NGS

GK: Gas Spring (KALLER) GD: Gas Spring (DADCO) GS: Gas Spring (SDT)
NGK/NGD/NGS: Without Gas Spring Parts for spring assembly are included.



Catalog No.	W	θ	PS	Option	
UCMSL	500	—	05	—	GK
UCMSL	600	—	05	—	NGK
UCMSL	500	—	05	—	GK — NF



Option Code	Specification
NF	Nitrogen gas not charged.

Spring Specification

No.	PS	Spring Model	Qty	Remark
15	GK	K750-80-TD	2	Gas Spring (KALLER)
	GD	L.750.075.TO.140	2	Gas Spring (DADCO)
	GS	SM0750.75	2	Gas Spring (SDT)

Weight

W	Cam Slider Weight kg	Total Weight kg
500	106.1	262.4
600	112.9	269.2

Rear Removal Space

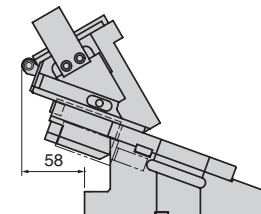

Refer to page 869 for Table of Components.

UCMSL Large Type

Aerial Cam Unit

For Pierce

For Trim

For Flange

UCMSL500-10/UCMSL600-10



● Cam Diagram

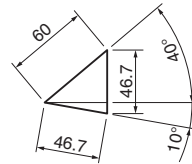

The Cam Diagram shows no Roller Bracket assemblies or Accelerators. If these items are needed, please contact local sales representative.

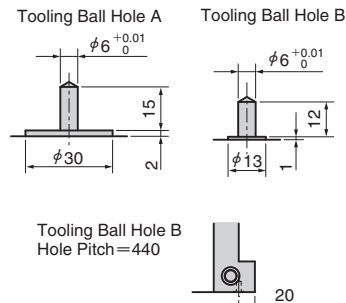
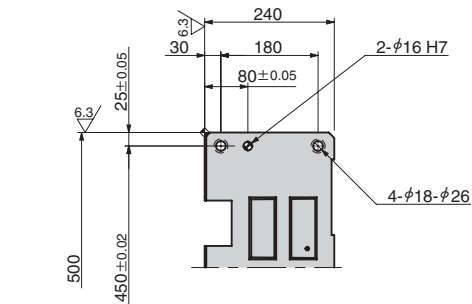
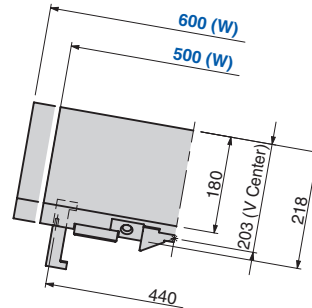
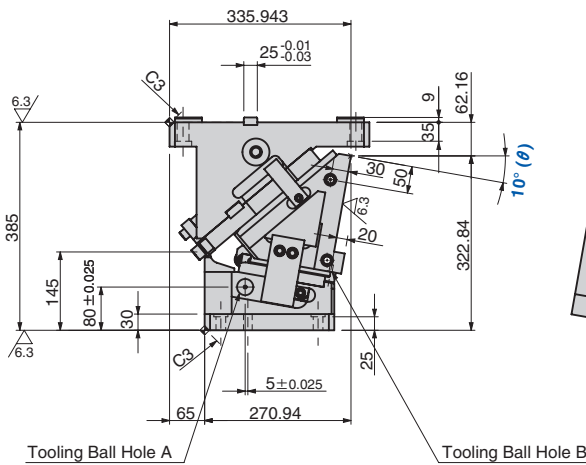
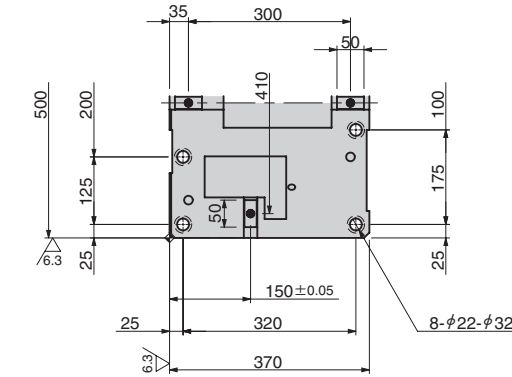

Travel S	Working Force kN (tonf)	Spring Force N (kgf)		Return Force N (kgf)	Catalog No.	W	θ	Spring Type PS
		Initial Load	Final Load					
46.7	313.6 (32.0)	—	18682.0 (1906.3)	25381 (2589.9)	UCMSL	500 600	10	GK NGK GD NGD GS NGS

GK: Gas Spring (KALLER) GD: Gas Spring (DADCO) GS: Gas Spring (SDT)
NGK/NGD/NGS: Without Gas Spring Parts for spring assembly are included.



Order

Catalog No.	W	θ	PS	Option
UCMSL	500	10	GK	
UCMSL	600	10	NGK	
UCMSL	500	10	GK	- NF



Option

Option Code	Specification
NF	Nitrogen gas not charged.

Spring Specification

No.	PS	Spring Model	Qty	Remark
15	GK	K750-80-TD	2	Gas Spring (KALLER)
	GD	L.750.075.TO.140	2	Gas Spring (DADCO)
	GS	SM0750.75	2	Gas Spring (SDT)

Weight

W	Cam Slider Weight kg	Total Weight kg
500	106.1	261.0
600	112.9	267.9

Rear Removal Space

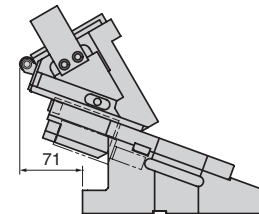

Refer to page 869 for Table of Components.

UCMSL Large Type

Aerial Cam Unit

For Pierce

For Trim

For Flange

UCMSL500-15/UCMSL600-15



● Cam Diagram

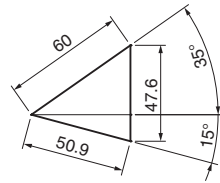

The Cam Diagram shows no Roller Bracket assemblies or Accelerators. If these items are needed, please contact local sales representative.

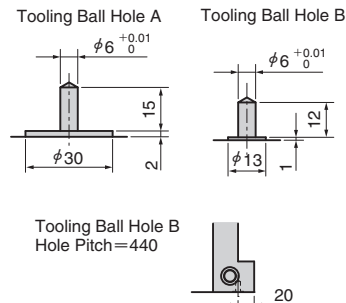
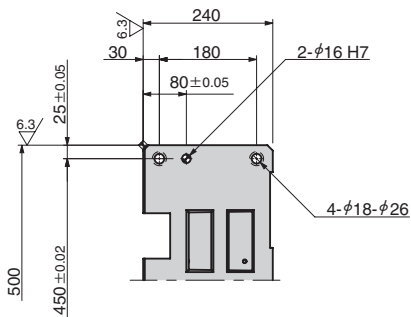
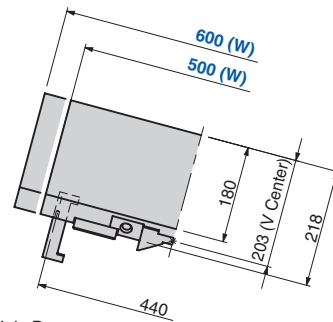
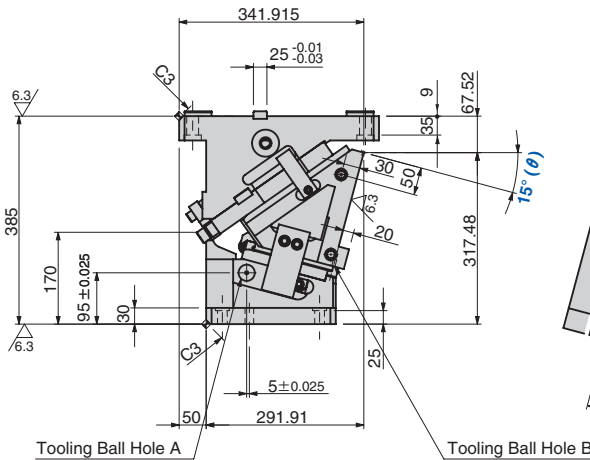
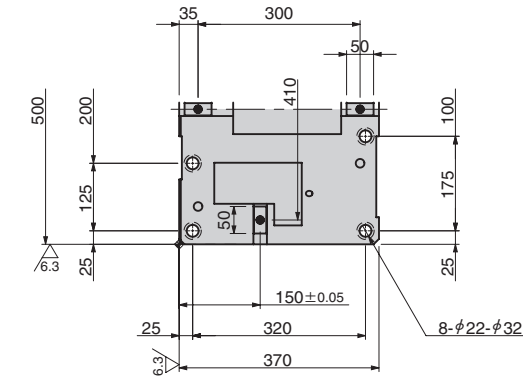

Travel S	Working Force kN (tonf)	Spring Force N (kgf)		Return Force N (kgf)	Catalog No.	W	θ	Spring Type PS
		Initial Load	Final Load					
50.9	313.6 (32.0)	—	18682.0 (1906.3)	25275 (2579.1)	UCMSL	500 600	15	GK NGK GD NGD GS NGS

GK: Gas Spring (KALLER) GD: Gas Spring (DADCO) GS: Gas Spring (SDT)
NGK/NGD/NGS: Without Gas Spring Parts for spring assembly are included.



Order

Catalog No.	W	θ	PS	Option
UCMSL	500	15	GK	
UCMSL	600	15	NGK	
UCMSL	500	15	GK	NF



Option

Option Code	Specification
NF	Nitrogen gas not charged.

Spring Specification

No.	PS	Spring Model	Qty	Remark
15	GK	K750-80-TD	2	Gas Spring (KALLER)
	GD	L.750.075.TO.140	2	Gas Spring (DADCO)
	GS	SM0750.75	2	Gas Spring (SDT)

Weight

W	Cam Slider Weight kg	Total Weight kg
500	106.1	260.2
600	112.9	267.1

Rear Removal Space

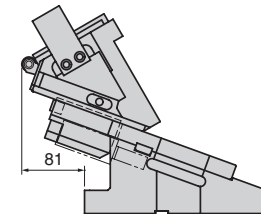

Refer to page 869 for Table of Components.

UCMSL Large Type

Aerial Cam Unit

For Pierce

For Trim

For Flange

UCMSL500-20/UCMSL600-20

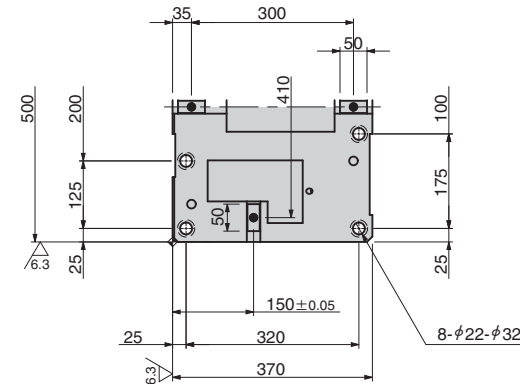

● Cam Diagram

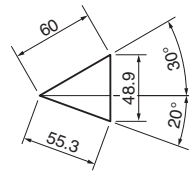

The Cam Diagram shows no Roller Bracket assemblies or Accelerators. If these items are needed, please contact local sales representative.

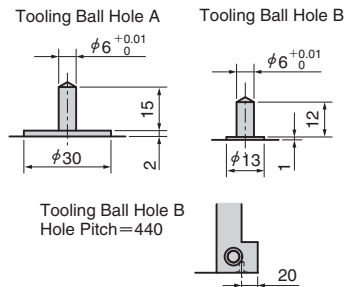
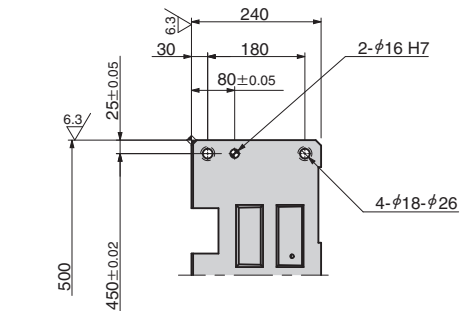
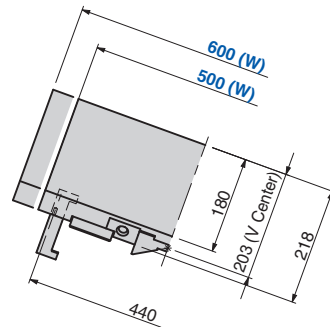
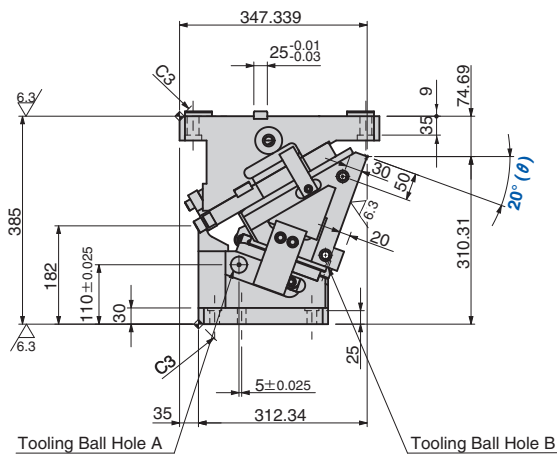

Travel S	Working Force kN (tonf)	Spring Force N (kgf)		Return Force N (kgf)	Catalog No.	W	θ	Spring Type PS
		Initial Load	Final Load					
55.3	313.6 (32.0)	—	18682.0 (1906.3)	25164 (2567.8)	UCMSL	500 600	20	GK NGK GD NGD GS NGS

GK: Gas Spring (KALLER) GD: Gas Spring (DADCO) GS: Gas Spring (SDT)
NGK/NGD/NGS: Without Gas Spring Parts for spring assembly are included.



Catalog No.	W	θ	PS	Option
UCMSL	500	20	GK	
UCMSL	600	20	NGK	
UCMSL	500	20	GK	NF



Option Code	Specification
NF	Nitrogen gas not charged.

Spring Specification

No.	PS	Spring Model	Qty	Remark
15	GK	K750-80-TD	2	Gas Spring (KALLER)
	GD	L.750.075.TO.140	2	Gas Spring (DADCO)
	GS	SM0750.75	2	Gas Spring (SDT)

Weight

W	Cam Slider Weight kg	Total Weight kg
500	106.1	260.7
600	112.9	267.6

Rear Removal Space

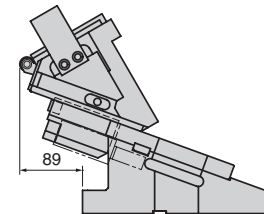

Refer to page 869 for Table of Components.

UCMSL Large Type

For Pierce

For Trim

For Flange

Aerial Cam Unit

UCMSL500-25/UCMSL600-25

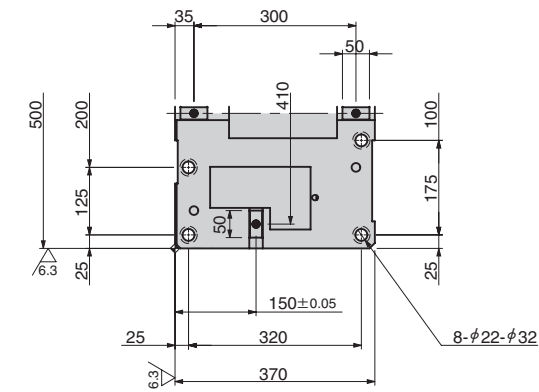

● Cam Diagram

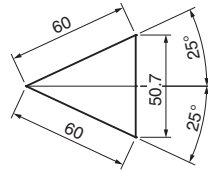

The Cam Diagram shows no Roller Bracket assemblies or Accelerators. If these items are needed, please contact local sales representative.

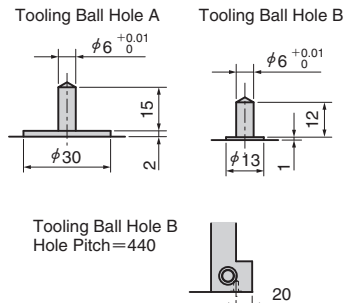
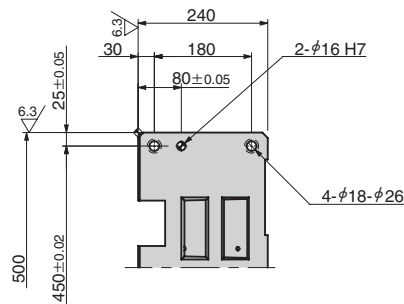
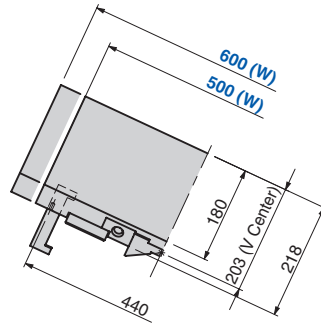
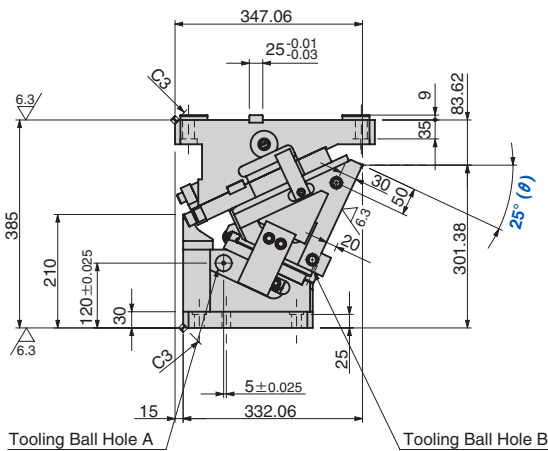

Travel S	Working Force kN (tonf)	Spring Force N (kgf)		Return Force N (kgf)	Catalog No.	W	θ	Spring Type PS
		Initial Load	Final Load					
60.0	313.6 (32.0)	—	18682.0 (1906.3)	25050 (2556.1)	UCMSL	500 600	25	GK NGK GD NGD GS NGS

GK: Gas Spring (KALLER) GD: Gas Spring (DADCO) GS: Gas Spring (SDT)
NGK/NGD/NGS: Without Gas Spring Parts for spring assembly are included.



Catalog No.	W	θ	PS	Option
UCMSL	500	25	GK	
UCMSL	600	25	NGK	
UCMSL	500	25	GK	NF



Option Code	Specification
NF	Nitrogen gas not charged.

Spring Specification

No.	PS	Spring Model	Qty	Remark
15	GK	K750-80-TD	2	Gas Spring (KALLER)
	GD	L.750.075.TO.140	2	Gas Spring (DADCO)
	GS	SM0750.75	2	Gas Spring (SDT)

Weight

W	Cam Slider Weight kg	Total Weight kg
500	106.1	260.8
600	112.9	267.7

Rear Removal Space

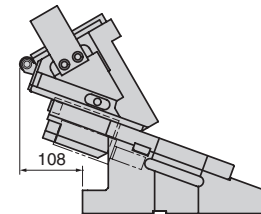

Refer to page 869 for Table of Components.

UCMSL

Large Type

For Pierce For Trim For Flange

Aerial Cam Unit

UCMSL500-30/UCMSL600-30



● Cam Diagram

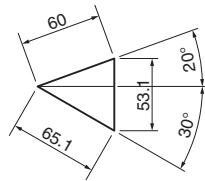

The Cam Diagram shows no Roller Bracket assemblies or Accelerators. If these items are needed, please contact local sales representative.

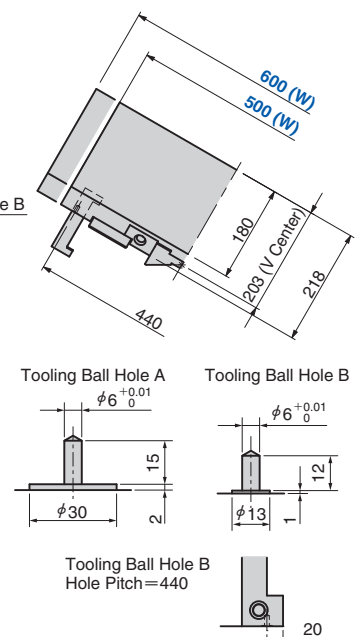
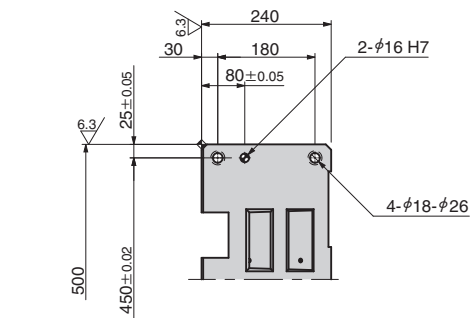
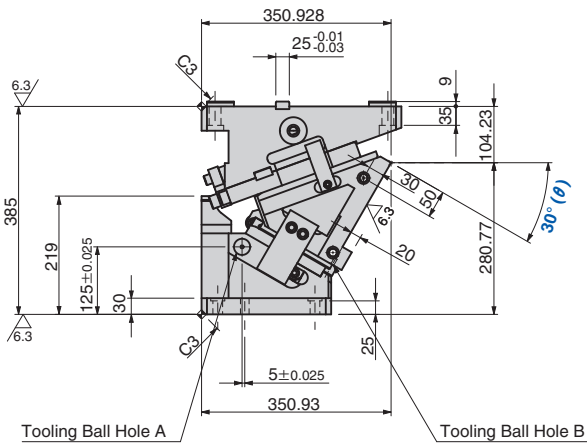
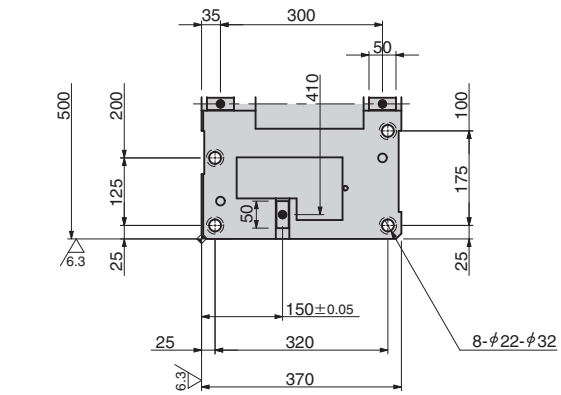

Travel S	Working Force kN (tonf)	Spring Force N (kgf)		Return Force N (kgf)	Catalog No.	W	θ	Spring Type PS
		Initial Load	Final Load					
65.1	313.6 (32.0)	—	18682.0 (1906.3)	24932 (2544.1)	UCMSL	500 600	30	GK NGK GD NGD GS NGS

GK: Gas Spring (KALLER) GD: Gas Spring (DADCO) GS: Gas Spring (SDT)
NGK/NGD/NGS: Without Gas Spring Parts for spring assembly are included.



Catalog No.	W	θ	PS	Option
UCMSL	500	30	GK	
UCMSL	600	30	NGK	
UCMSL	500	30	GK	NF



Option Code	Specification
NF	Nitrogen gas not charged.

Spring Specification

No.	PS	Spring Model	Qty	Remark
15	GK	K750-80-TD	2	Gas Spring (KALLER)
	GD	L.750.075.TO.140	2	Gas Spring (DADCO)
	GS	SM0750.75	2	Gas Spring (SDT)

Weight

W	Cam Slider Weight kg	Total Weight kg
500	106.1	264.4
600	112.9	271.3

Rear Removal Space

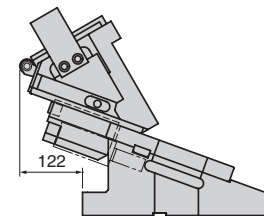

Refer to page 869 for Table of Components.

UCMSL

Large Type

For Pierce

For Trim

For Flange

Aerial Cam Unit

UCMSL500-35/UCMSL600-35



● Cam Diagram

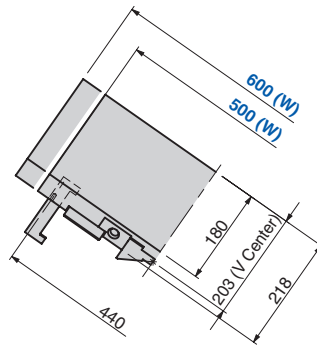
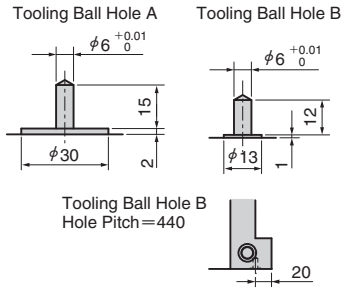
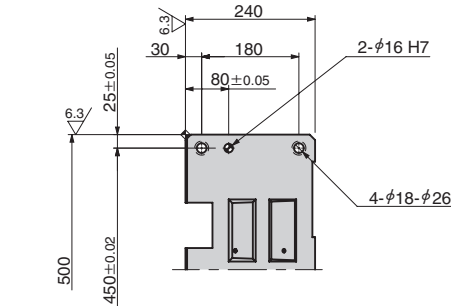
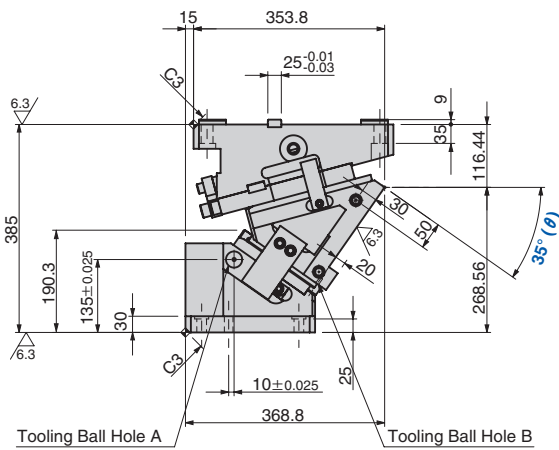
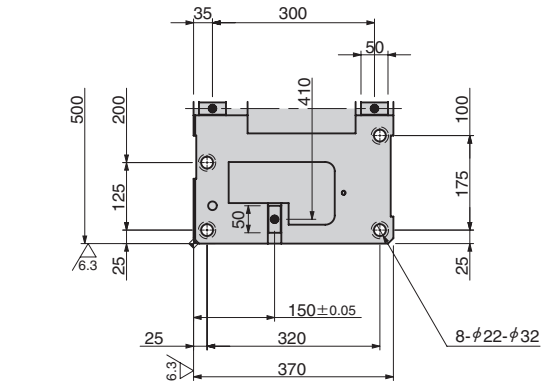
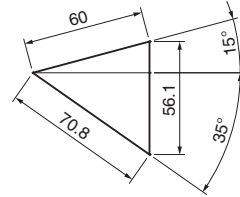

Travel S	Working Force kN (tonf)	Spring Force N (kgf)		Return Force N (kgf)	Catalog No.	W	θ	Spring Type PS
		Initial Load	Final Load					
70.8	313.6 (32.0)	—	18682.0 (1906.3)	24813 (2531.9)	UCMSL	500 600	35	GK NGK GD NGD GS NGS

GK: Gas Spring (KALLER) GD: Gas Spring (DADCO) GS: Gas Spring (SDT)
NGK/NGD/NGS: Without Gas Spring Parts for spring assembly are included.



Catalog No.	W	θ	PS	Option
UCMSL	500	35	GK	
UCMSL	600	35	NGK	
UCMSL	500	35	GK	NF



Option Code	Specification
NF	Nitrogen gas not charged.

Spring Specification

No.	PS	Spring Model	Qty	Remark
15	GK	K750-80-TD	2	Gas Spring (KALLER)
	GD	L.750.075.TO.140	2	Gas Spring (DADCO)
	GS	SM0750.75	2	Gas Spring (SDT)

Weight

W	Cam Slider Weight kg	Total Weight kg
500	106.1	269.9
600	112.9	276.7

Rear Removal Space

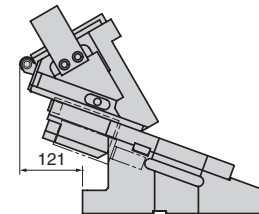

Refer to page 869 for Table of Components.

UCMSL Large Type

Aerial Cam Unit

For Pierce

For Trim

For Flange

UCMSL500-40/UCMSL600-40



● Cam Diagram

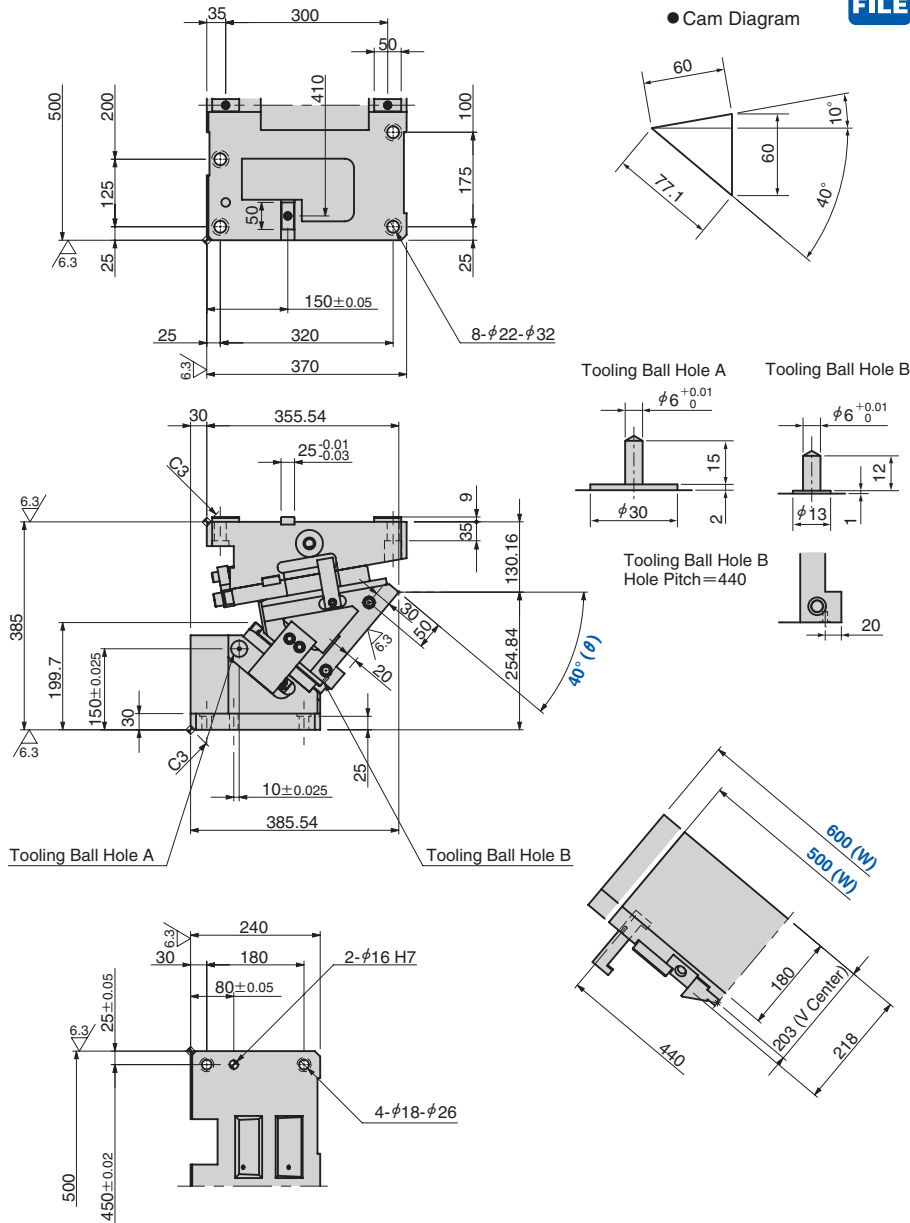

Travel S	Working Force kN (tonf)	Spring Force N (kgf)		Return Force N (kgf)	Catalog No.	W	θ	Spring Type PS
		Initial Load	Final Load					
77.1	313.6 (32.0)	—	18682.0 (1906.3)	24692 (2519.6)	UCMSL	500 600	40	GK NGK GD NGD GS NGS

GK: Gas Spring (KALLER) GD: Gas Spring (DADCO) GS: Gas Spring (SDT)
NGK/NGD/NGS: Without Gas Spring Parts for spring assembly are included.



Catalog No.	W	θ	PS	Option
UCMSL	500	40	GK	
UCMSL	600	40	NGK	
UCMSL	500	40	GK	NF



Option Code	Specification
NF	Nitrogen gas not charged.

Spring Specification

No.	PS	Spring Model	Qty	Remark
15	GK	K750-80-TD	2	Gas Spring (KALLER)
	GD	L.750.075.TO.140	2	Gas Spring (DADCO)
	GS	SM0750.75	2	Gas Spring (SDT)

Weight

W	Cam Slider Weight kg	Total Weight kg
500	106.1	274.5
600	112.9	281.3

Rear Removal Space

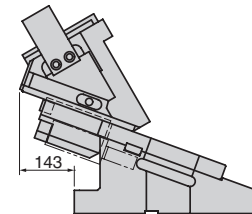

Refer to page 869 for Table of Components.

UCMSL Large Type

Aerial Cam Unit

For Pierce

For Trim

For Flange

UCMSL500-45/UCMSL600-45



● Cam Diagram

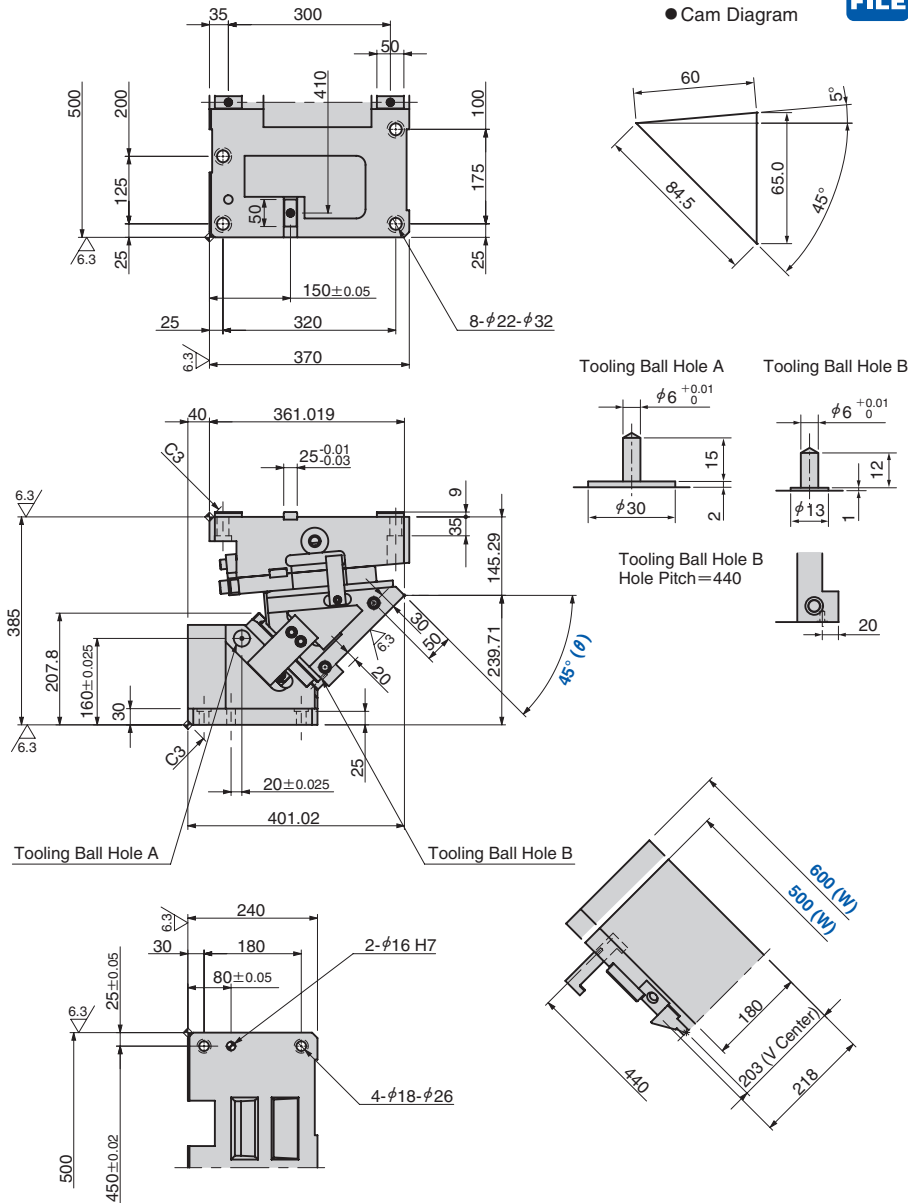

Travel S	Working Force kN (tonf)	Spring Force N (kgf)		Return Force N (kgf)	Catalog No.	W	θ	Spring Type PS
		Initial Load	Final Load					
84.5	313.6 (32.0)	—	18682.0 (1906.3)	24571 (2507.2)	UCMSL	500 600	45	GK NGK GD NGD GS NGS

GK: Gas Spring (KALLER) GD: Gas Spring (DADCO) GS: Gas Spring (SDT)
NGK/NGD/NGS: Without Gas Spring Parts for spring assembly are included.



Order

Catalog No.	W	θ	PS	Option
UCMSL	500	45	GK	
UCMSL	600	45	NGK	
UCMSL	500	45	GK	NF



Option

Option Code	Specification
NF	Nitrogen gas not charged.

Spring Specification

No.	PS	Spring Model	Qty	Remark
15	GK	K750-80-TD	2	Gas Spring (KALLER)
	GD	L.750.075.TO.140	2	Gas Spring (DADCO)
	GS	SM0750.75	2	Gas Spring (SDT)

Weight

W	Cam Slider Weight kg	Total Weight kg
500	106.1	281.6
600	112.9	288.5

Rear Removal Space

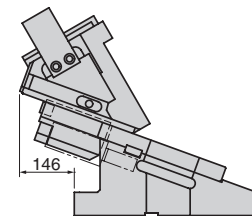

Refer to page 869 for Table of Components.

UCMSL Large Type

Aerial Cam Unit

For Pierce

For Trim

For Flange

UCMSL500-50/UCMSL600-50



● Cam Diagram

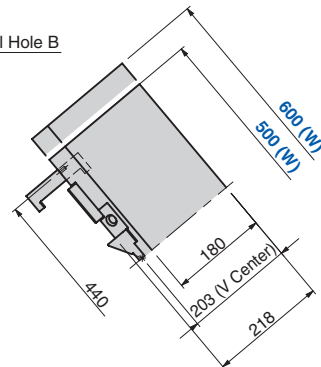
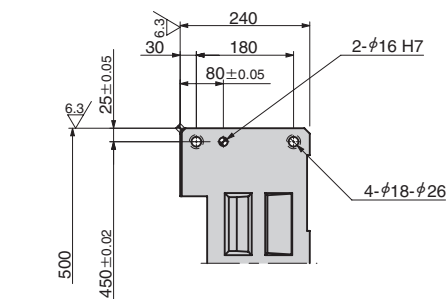
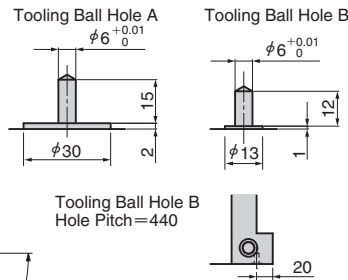
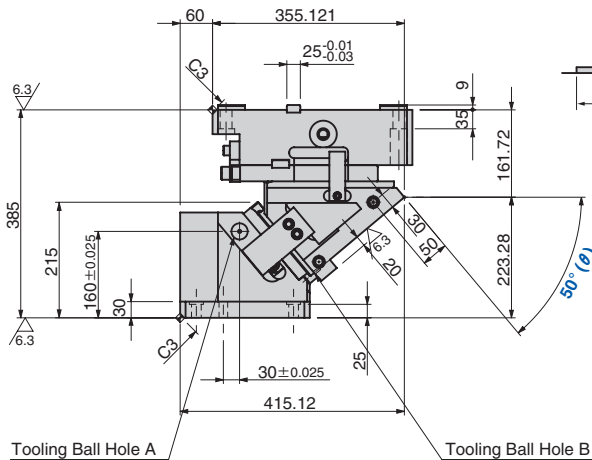
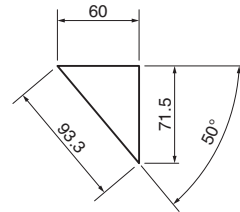
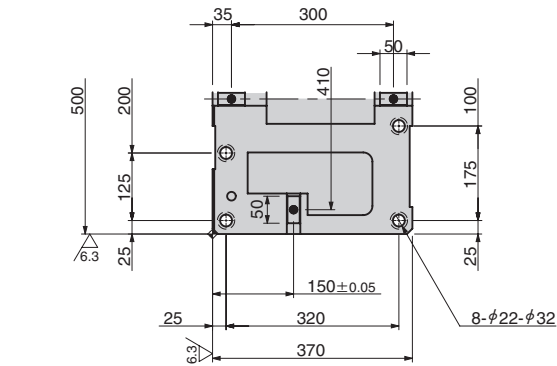

Travel S	Working Force kN (tonf)	Spring Force N (kgf)		Return Force N (kgf)	Catalog No.	W	θ	Spring Type PS
		Initial Load	Final Load					
93.3	313.6 (32.0)	—	18682.0 (1906.3)	24451 (2495.0)	UCMSL	500 600	50	GK NGK GD NGD GS NGS

GK: Gas Spring (KALLER) GD: Gas Spring (DADCO) GS: Gas Spring (SDT)
NGK/NGD/NGS: Without Gas Spring Parts for spring assembly are included.



Order

Catalog No.	W	θ	PS	Option
UCMSL	500	50	GK	
UCMSL	600	50	NGK	
UCMSL	500	50	GK	NF



Option

Option Code	Specification
NF	Nitrogen gas not charged.

Spring Specification

No.	PS	Spring Model	Qty	Remark
15	GK	K750-80-TD	2	Gas Spring (KALLER)
	GD	L.750.075.TO.140	2	Gas Spring (DADCO)
	GS	SM0750.75	2	Gas Spring (SDT)

Weight

W	Cam Slider Weight kg	Total Weight kg
500	106.1	282.0
600	112.9	288.9

Rear Removal Space

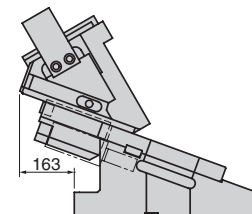

Refer to page 869 for Table of Components.

UCMSL Large Type

Aerial Cam Unit

For Pierce

For Trim

For Flange

UCMSL500-55/UCMSL600-55

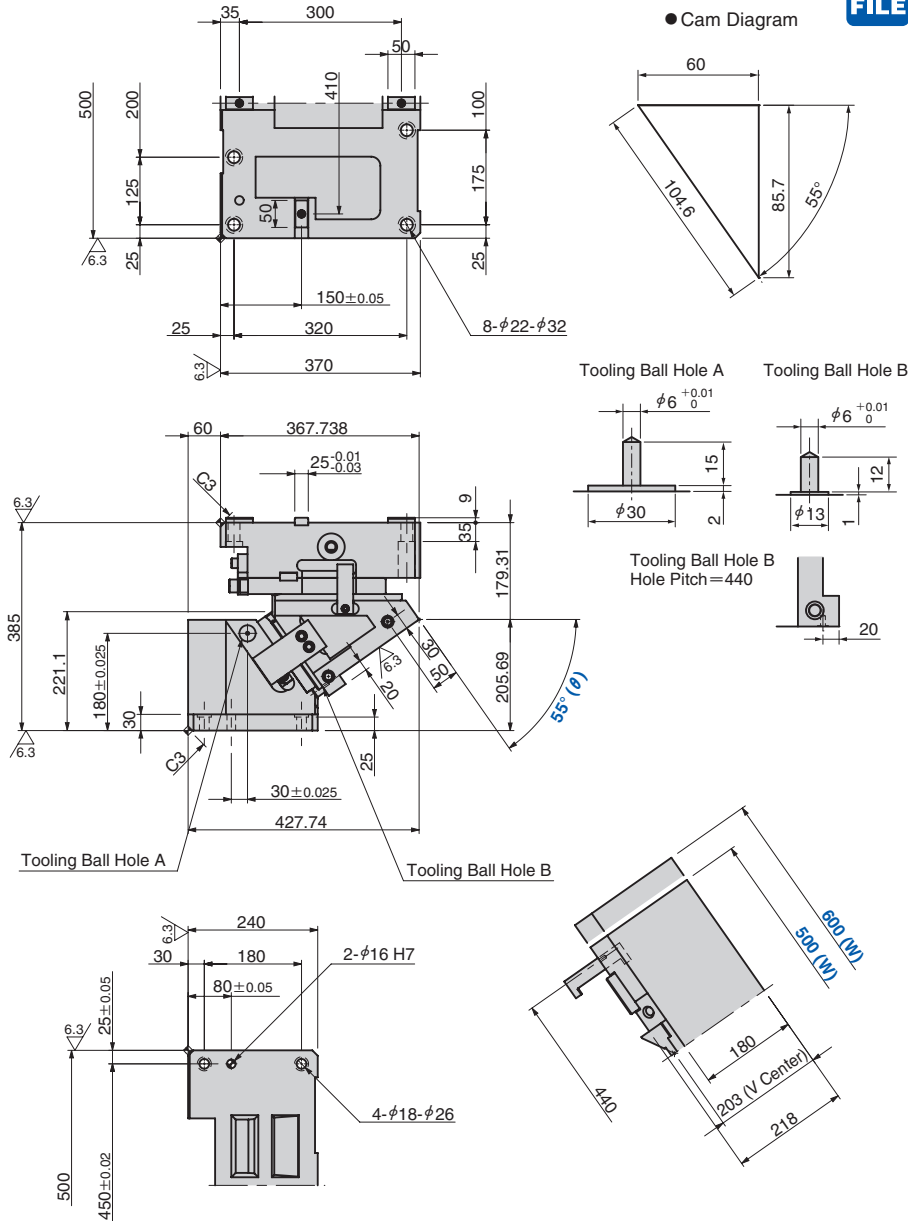

Travel S	Working Force kN (tonf)	Spring Force N (kgf)		Return Force N (kgf)	Catalog No.	W	θ	Spring Type PS
		Initial Load	Final Load					
104.6	313.6 (32.0)	—	18682.0 (1906.3)	26590 (2713.2)	UCMSL	500 600	55	GK NGK GD NGD GS NGS

GK: Gas Spring (KALLER) GD: Gas Spring (DADCO) GS: Gas Spring (SDT)
NGK/NGD/NGS: Without Gas Spring Parts for spring assembly are included.



Catalog No.	W	θ	PS	Option
UCMSL	500	55	GK	
UCMSL	600	55	NGK	
UCMSL	500	55	GK	NF



Option Code	Specification
NF	Nitrogen gas not charged.

Spring Specification

No.	PS	Spring Model	Qty	Remark
15	GK	K750-80-TD	2	Gas Spring (KALLER)
	GD	L.750.075.TO.140	2	Gas Spring (DADCO)
	GS	SM0750.75	2	Gas Spring (SDT)

Weight

W	Cam Slider Weight kg	Total Weight kg
500	106.1	291.5
600	112.9	299.2

Rear Removal Space

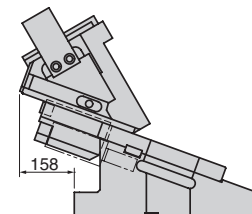

Refer to page 869 for Table of Components.

UCMSL

Large Type

For Pierce For Trim For Flange

Aerial Cam Unit

UCMSL500-60/UCMSL600-60

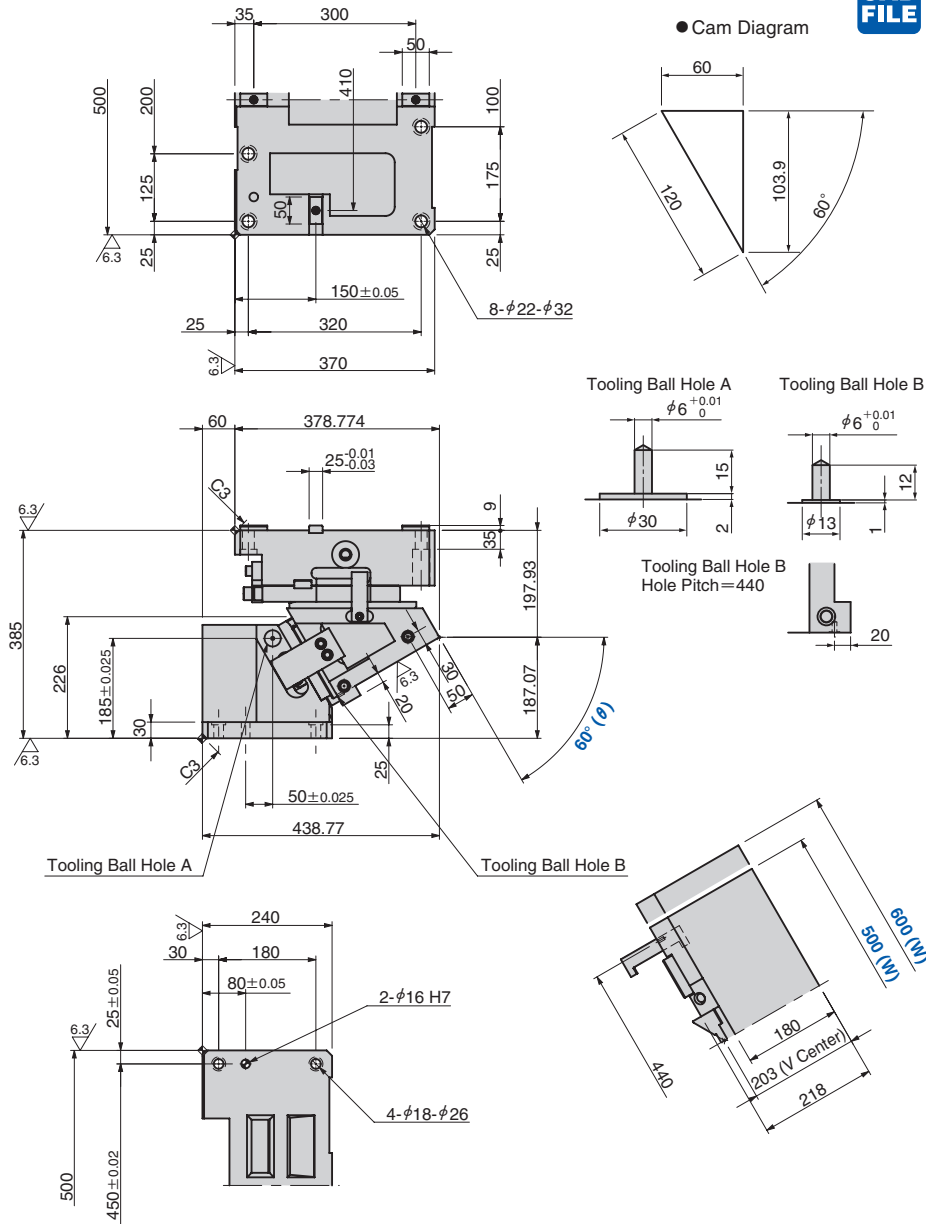

Travel S	Working Force kN (tonf)	Spring Force N (kgf)		Return Force N (kgf)	Catalog No.	W	θ	Spring Type PS
		Initial Load	Final Load					
120.0	313.6 (32.0)	—	18682.0 (1906.3)	29388 (2998.8)	UCMSL	500 600	60	GK NGK GD NGD GS NGS

GK: Gas Spring (KALLER) GD: Gas Spring (DADCO) GS: Gas Spring (SDT)
NGK/NGD/NGS: Without Gas Spring Parts for spring assembly are included.



Catalog No.	W	θ	PS	Option
UCMSL	500	60	GK	
UCMSL	600	60	NGK	
UCMSL	500	60	GK	NF



Option Code	Specification
NF	Nitrogen gas not charged.

Spring Specification

No.	PS	Spring Model	Qty	Remark
15	GK	K750-80-TD	2	Gas Spring (KALLER)
	GD	L.750.075.TO.140	2	Gas Spring (DADCO)
	GS	SM0750.75	2	Gas Spring (SDT)

Weight

W	Cam Slider Weight kg	Total Weight kg
500	106.1	300.1
600	112.9	308.7

Rear Removal Space

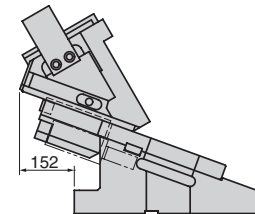

Refer to page 869 for Table of Components.

UCMSL [Table of Components]

Large Type

For Pierce

For Trim

For Flange

Aerial Cam Unit

UCMSL500/UCMSL600

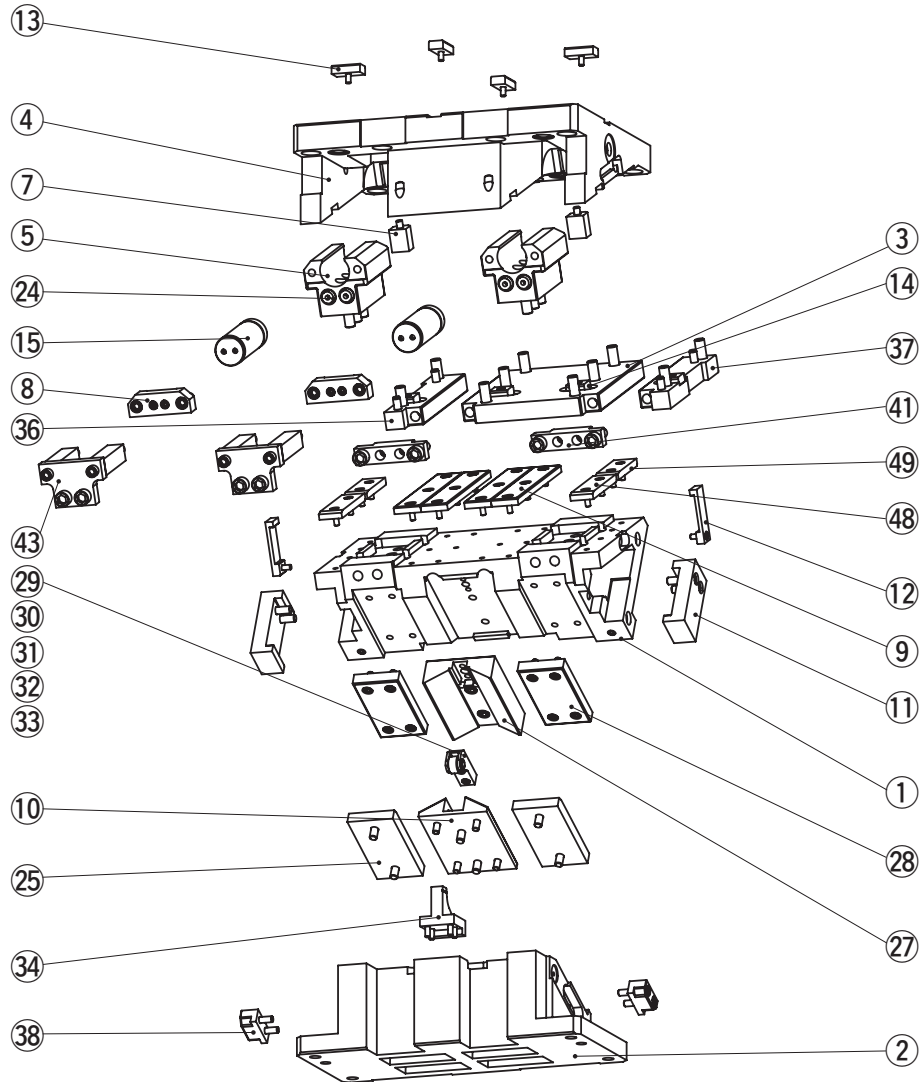

No.	Description	Qty	Material and Remark
1	Cam Slider	1	Cast Iron
2	Cam Driver	1	Cast Iron
3	Base Plate A	1	Steel
4	Cam Holder	1	Cast Iron
5	Spring Guide Block	2	Bronze with Graphite
6	Slide Lower Plate A	2	Bronze with Graphite 55°~60° only
7	Guide Pin Block	2	Steel
8	Spring Guide Plate	2	Steel
9	Slide Lower Plate B	4	Bronze with Graphite
10	Cam Slide Guide	1	Bronze with Graphite
11	Positive Return Follower	2	Steel
12	Safety Plate	2	Steel
13	Key A	4	Steel
14	Key B	4	Steel
15	Gas Spring	2	Refer to the Spring Specification.
24	Stopper	4	—
25	Cam Slide Plate A	2	Bronze with Graphite
27	Cam Slide Guide	1	Steel
28	Lower Slide Plate	2	Steel
29	Roller Bracket	1	Steel 0°~30° only
30	Roller	1	Steel 0°~30° only
31	Roller Pin	1	Steel 0°~30° only
32	Bushing	1	SOB12-18-16 0°~30° only
33	Snap Ring E Type	2	φ 9 0°~30° only
34	Roller Driver	1	Steel 0°~30° only
36	Base Plate B R	1	Steel
37	Base Plate B L	1	Steel
38	Positive Return Block	2	Bronze with Graphite
41	Stopper Plate	2	Steel
43	Locking Plate	2	Steel
48	Slide Plate	2	Bronze with Graphite
49	Slide Plate	2	Bronze with Graphite

Bolts, nuts, dowels, and washers for assembly are not indicated.