

**Product Information**

- Complies with VDI.
- Compact design.
- High working forces.
- Suitable for high speed production.
- Bronze with solid lubricants wear plates.

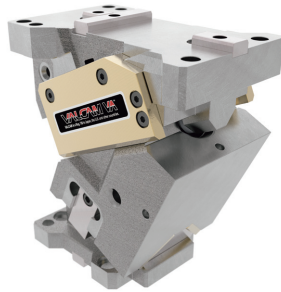

Mount face width	Working Force [kN] 1,000,000 strokes	Working Angle (5° increments)	Catalog No.	Spring Type
65	117	0°~75°	VACBV65	
85	162	0°~75°	VACBV85	
110	206	0°~75°	VACBV110	
165	323	0°~75°	VACBV165	
200	515	0°~75°	VACBV200	
260	603	0°~75°	VACBV260	
330	735	0°~75°	VACBV330	
400	882	0°~75°	VACBV400	

\* Mount face widths 200, 260, 300, and 400 mm available in June 2024.

**Key specifications**

- Cam width 65, 85, 110, 165  
(A M8 bolt is included.)

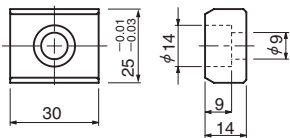

- Cam width 110  
(A M8 bolt is included.)

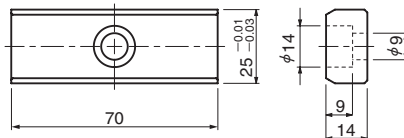

- Cam width 65, 85, 110, 165, 200, 260, 330, 400  
LKU25-50 (A M8 bolt is included.)

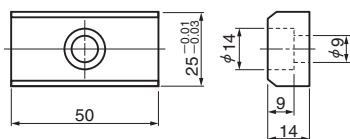

- Cam width 165  
LKU25-100 (A M8 bolt is included.)

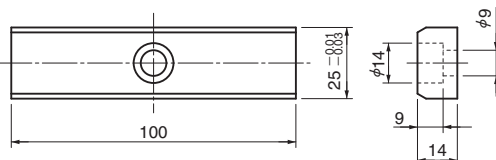

**VACBV65-85 Assembly Instructions**

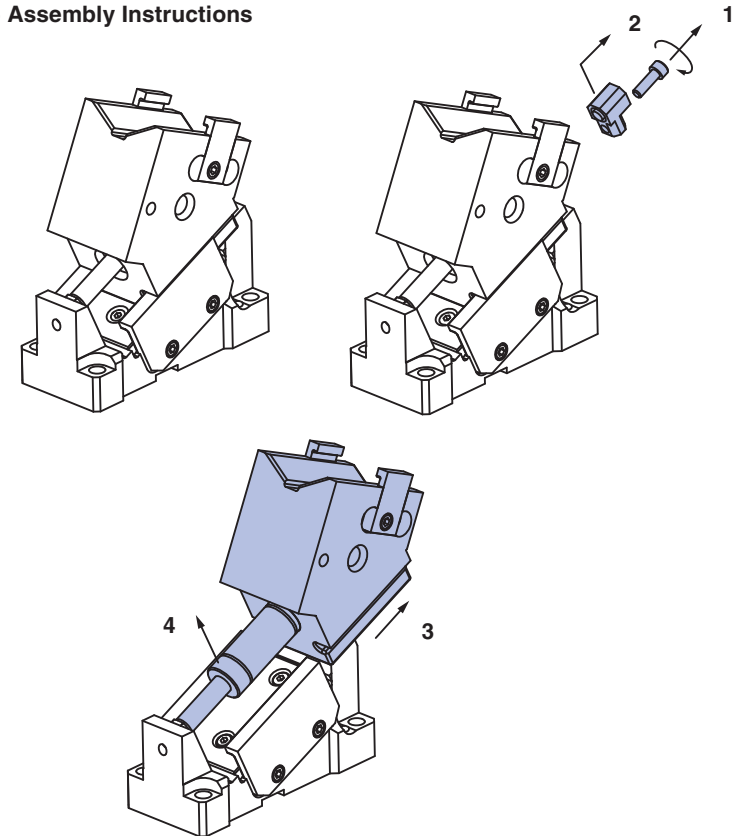

- Disassembly
  - 1) Remove Hexagon Socket Head Bolts.
  - 2) Pull out Stopper Plate.
  - 3) Remove Cam Slider to the rear. (until Gas Spring is removable.)
  - 4) Remove Gas Spring.

- Assembly
 

Assembly is the reverse procedure of disassembly.

  - Ensure that all parts are clean, particularly the sliding components to which a small amount of lubricant is applied and is then placed in position.
  - Take care that the respective tolerances are observed when assembling Cam Slider and Cam Holder, which also should be identified by the same serial number.
  - Make sure that all bolts are tighten to the recommended torque after assembly and disassembly.

- ⚠ Gas Spring
 

Please contact your local sales representative if you prefer to use a gas spring not specified in our catalog. For use and maintenance of gas spring, please contact the manufacturer directly.

**Product Information**

■ VACBV110·165 Assembly Instructions

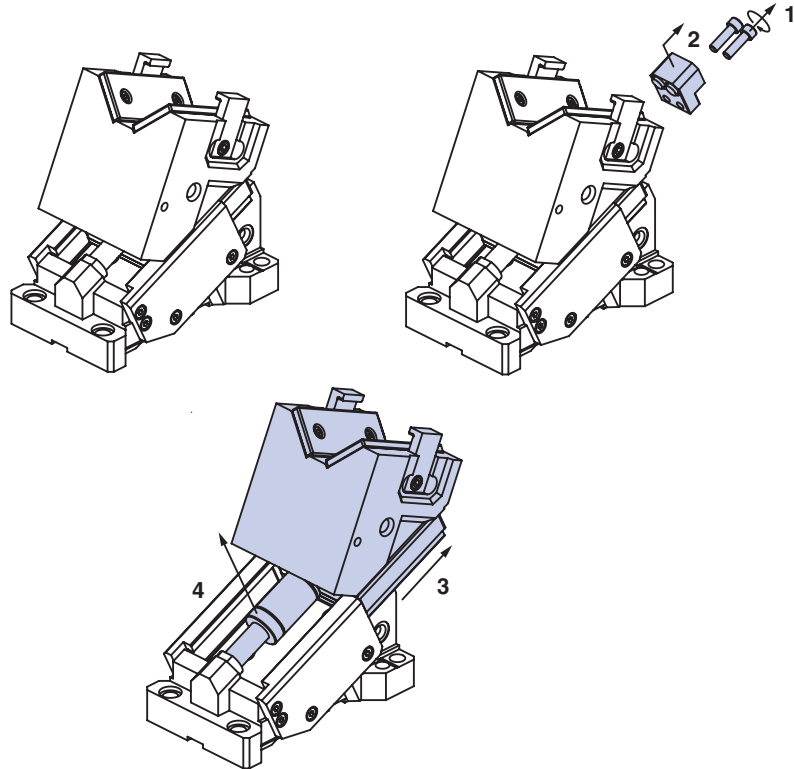

● Disassembly

- 1) Remove Hexagon Socket Head Bolts.
- 2) Pull out Stopper Plate.
- 3) Remove Cam Slider to the rear. (until Gas Spring is removable.)
- 4) Remove Gas Spring.

● Assembly

Assembly is the reverse procedure of disassembly.

- Ensure that all parts are clean, particularly the sliding components to which a small amount of lubricant is applied and is then placed in position.
- Take care that the respective tolerances are observed when assembling Cam Slider and Cam Holder, which also should be identified by the same serial number.
- Make sure that all bolts are tighten to the recommended torque after assembly and disassembly.

**⚠** Gas Spring

Please contact your local sales representative if you prefer to use a gas spring not specified in our catalog. For use and maintenance of gas spring, please contact the manufacturer directly.

■ VACBV200·260 Assembly Instructions

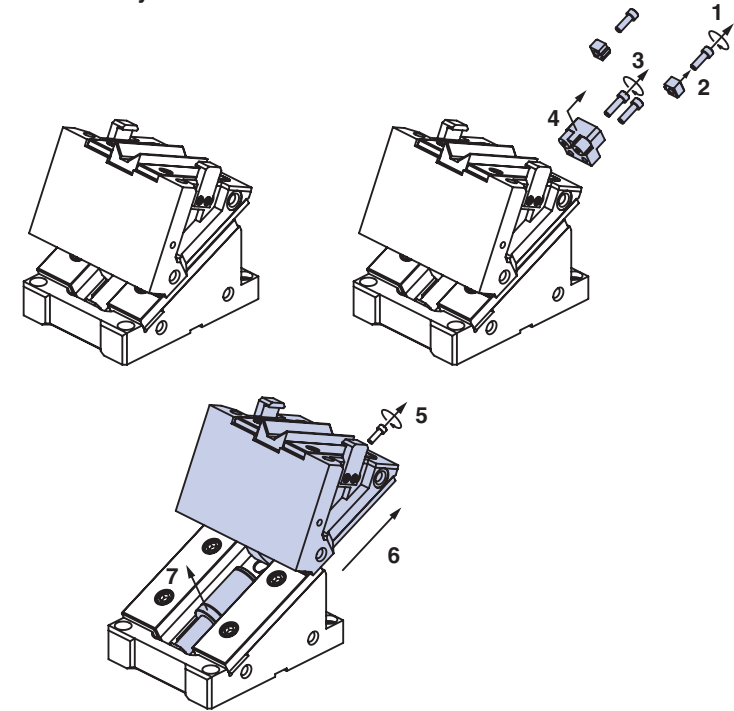

● Disassembly

- 1) Remove Hexagon Socket Head Bolts.
- 2) Pull out Stopper Plate.
- 3) Remove Hexagon Socket Head Bolts.
- 4) Pull out Stopper Plate.
- 5) Remove Hexagon Socket Head Bolts of Gas Spring.
- 6) Remove Cam Slider to the rear.
- 7) Remove Gas Spring.

● Assembly

Assembly is the reverse procedure of disassembly.

- Ensure that all parts are clean, particularly the sliding components to which a small amount of lubricant is applied and is then placed in position.
- Take care that the respective tolerances are observed when assembling Cam Slider and Cam Holder, which also should be identified by the same serial number.
- Make sure that all bolts are tighten to the recommended torque after assembly and disassembly.

**⚠** Gas Spring

Please contact your local sales representative if you prefer to use a gas spring not specified in our catalog. For use and maintenance of gas spring, please contact the manufacturer directly.

**Aerial Cam Unit**

Working Force [kN] 1,000,000 strokes	Catalog No.	W	$\theta$	Spring Type PS
603	<b>VACBV</b>	<b>260</b>	<b>00~75</b> (5° increments)	<b>GK NGK</b> <b>GD NGD</b>

GK: Gas Spring (KALLER) GD: Gas Spring (DADCO)  
NGK/NGD: Without Gas Spring Parts for spring assembly are included.

Order	Catalog No.	W	$\theta$	PS	Option
	<b>VACBV</b>	<b>260</b>	<b>10</b>	<b>GK</b>	
	<b>VACBV</b>	<b>260</b>	<b>10</b>	<b>GK</b>	<b>NF</b>

Option Code	Specification
<b>NF</b>	Nitrogen gas not charged.

**Spring Specification**

$\theta$	GK			GD		
	Final Load kN	Return Force kN	Spring Model	Final Load kN	Return Force kN	Spring Model
00		18.2			19.6	
05		18.2			19.5	
10		18.2			19.5	
15		18.1			19.5	
20		18.1			19.4	
25		18.0			19.4	
30	13.6	18.0	X1000-63	14.6	19.3	U.1000.063
35		18.0			19.3	
40		17.9			19.2	
45		17.9			19.2	
50		17.8			19.2	
55		19.4			20.8	
60		21.4			23.0	
65	13.1	23.4	X1000-63	14.0	25.0	U.1000.063
70	12.7	26.1	X1000-63	13.5	27.8	U.1000.063
75	12.4	30.7	X1000-50	13.3	32.7	U.1000.050

**Weight**

$\theta$	Total Weight kg	Cam Slider Weight kg	Max. Tool Length mm	Max. Tool Weight*1 kg
00	100.1			
05	98.9			
10	97.6			
15	96.0			
20	94.6			
25	93.2	41.4		
30	92.8			
35	92.3		130	35.0
40	92.6			
45	95.0			
50	95.7			
55	97.2	42.5		
60	97.4	41.8		
65	99.6	42.8		
70	104.2	46.4		
75	107.6	48.5		

**Rear Removal Space**

$\theta$	L mm
00	50
05	65
10	77
15	91
20	107
25	120
30	133
35	142
40	151
45	158
50	161
55	167
60	167
65	163
70	162
75	177

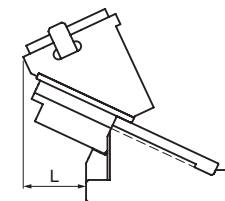

\*1 Tool weight is estimated value. Allowable tool weight varies depending on press speed.

**Cam Diagram**

$\theta$	WT	PT	ST	IW	Pic.
00	32.8	39.1			1
05	36.2	39.2			
10	39.7	39.7			
15	43.3	40.5			
20	47.0	41.6			
25	51.0	43.1			2
30	55.3	45.1	51		
35	60.1	47.7			
40	65.6	51.0			
45	71.9	55.3			
50	79.3	60.8		50	
55	88.9	72.8		55	
60	102.0	88.3		60	
65	108.8	98.6	46	65	3
70	119.9	112.6	41	70	
75	119.8	115.7	31	75	

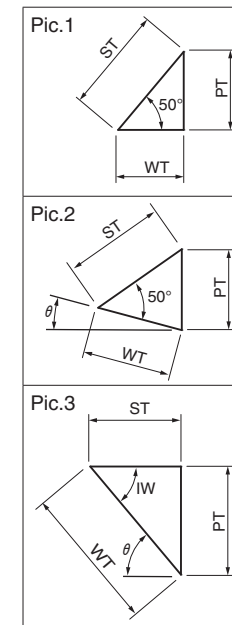

**Aerial Cam Unit**

VACBV260

**CAD FILE**

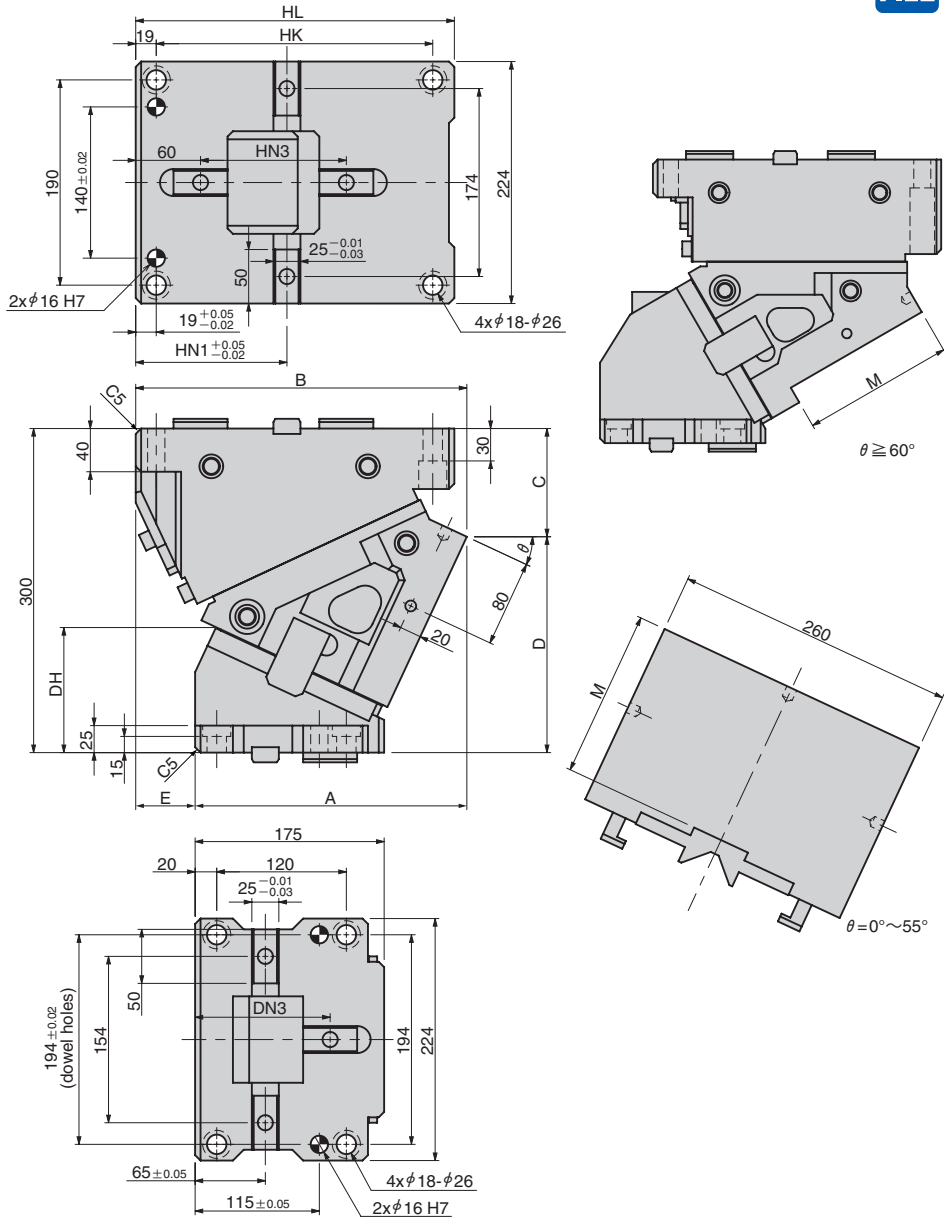

$\theta$	A	B	C	D	E	HL	HK	HN1	HN3	DH	DN3	M
00	175.00	291.00	67.00	233.00	116	270	231	130	115	61.0		
05	191.87	294.87	75.71	224.29	103	275	236	135	120	67.8		
10	208.34	299.34	82.22	217.78	91	280	241		125	77.9	115	
15	224.43	301.43	88.49	211.51	77	285	246		130	89.4		
20	239.16	304.16	94.48	205.52	65	290	251			102.0		
25	251.55	306.55	100.18	199.82	55	295	256		135	115.8		155
30	266.63	305.63	108.55	191.45	39	300	261			127.5		
35	281.43	306.43	117.57	182.43	25	305	266		140	139.0	125	
40	295.99	302.99	128.21	171.79	7	305	266		145	149.4		
45	307.33	298.33	147.45	152.55	-9	305	266	140		151.7		
50	318.50	293.50	157.27	142.73	-25					163.5		
55	334.25	290.25	161.13	138.87	-44					169.5		168
60	340.45	284.45	161.36	138.64	-56	305	266		150	172.5	140	
65	356.31	285.31	165.70	134.30	-71					177.0		160
70	375.62	285.62	176.95	123.05	-90					175.8		
75	387.77	280.77	184.35	115.65	-107					178.5		

**Working Force Distribution Diagram**

The working forces indicated in the mount face distribution diagram are reached by putting the tooling center of gravity within each area for the following pictures.

Working force (kN) allowed for up to 1,000,000 strokes

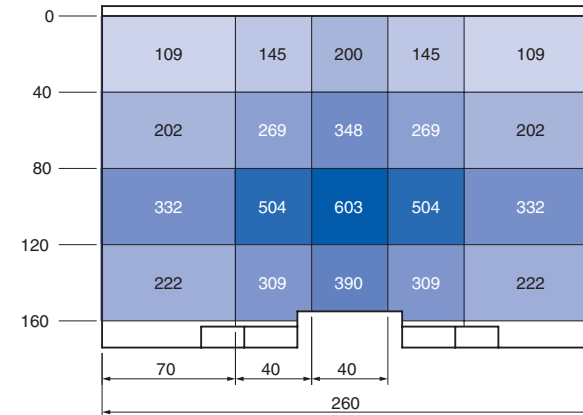

Refer to page 535 for Table of Components.

**Aerial Cam Unit**

VACBV200·260

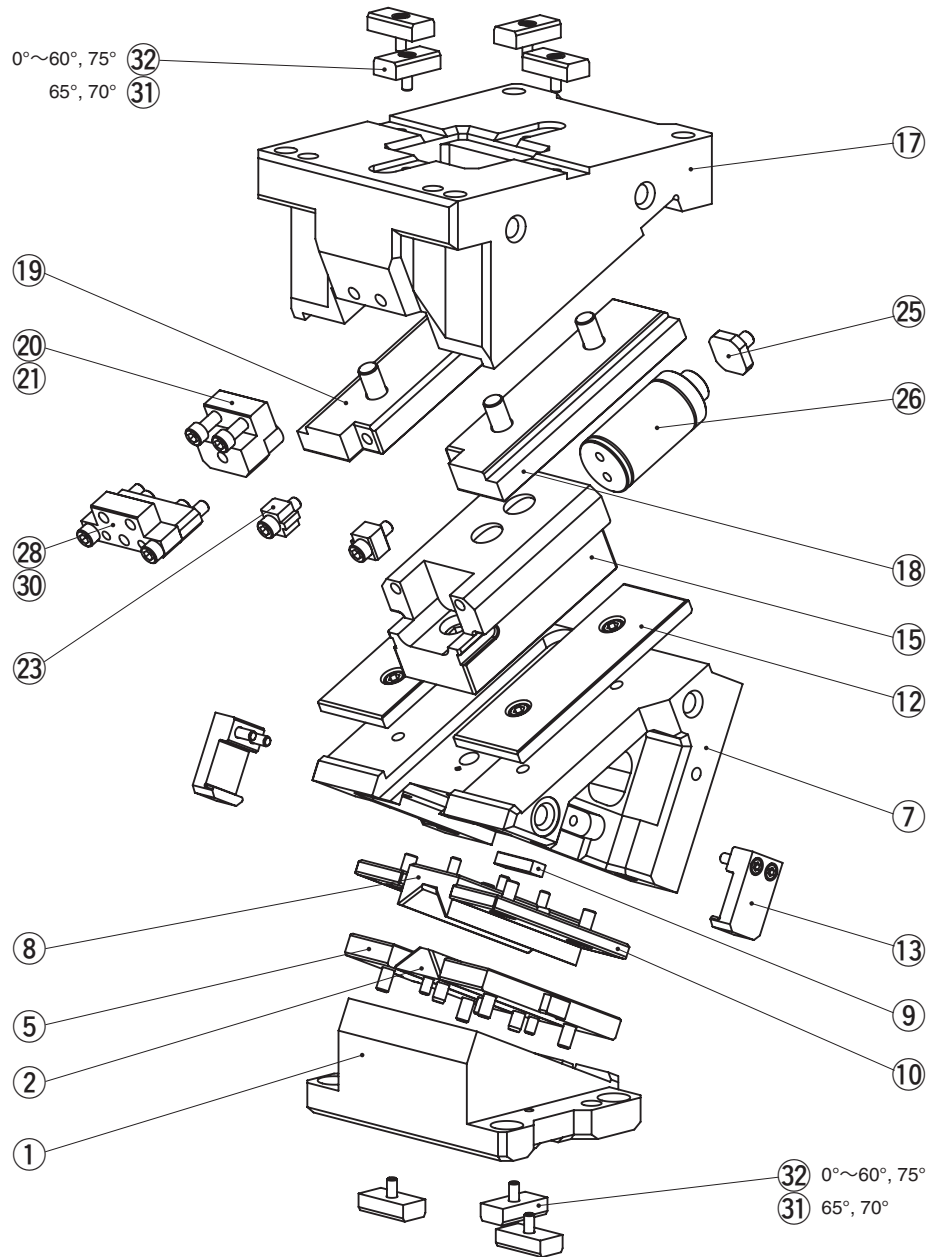

● Lock System

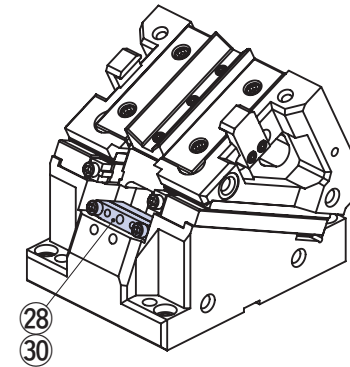

No.	Description	Qty	Material and Remark
1	Cam Driver	1	Cast Iron
2	Cam Slide Guide A	1	Bronze with Graphite
5	Driver Plate	2	Bronze with Graphite
7	Cam Slider	1	Cast Iron
8	Cam Slide Guide B	1	Steel
9	Key	1	Steel
10	Slide Plate 01	2	Steel
12	Slide Plate 02	2	Steel
13	Positive Return	2	Steel
15	Spring Guide Plate	1	Cast Iron
17	Cam Holder	1	Cast Iron
18	Base Plate 01A	1	Bronze with Graphite
19	Base Plate 01B	1	Bronze with Graphite
20	Stopper Plate	1	Steel
21	Stopper	2	—
23	Safety Block	2	Steel
25	Pin	1	Steel
26	Gas Spring	1	Refer to the Spring Specification.
28	Lock Plate 01	1	Steel
30	Lock Plate 02	1	Steel
31	Key	7	LKU25-50 65°, 70°
32	Key	7	LKU25-50 0°~60°, 75°

Bolts, nuts, dowels, and washers for assembly are not indicated.