

# Pusher Spring Head

FOR PUSHER (ACCESSORY)

CAD FILE

PSH

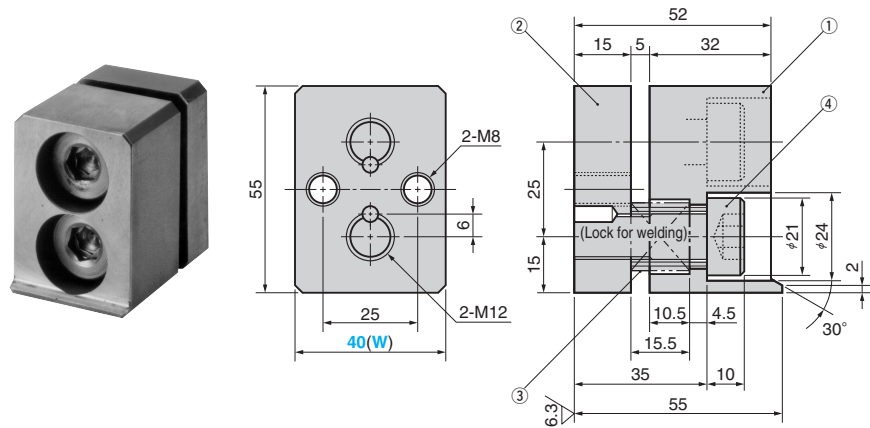

Load N(kgf)		Catalog No.	(W)
min	max		
37.8 (3.9)	79.8 (8.1)	<b>PSH</b>	<b>40</b>

Order

### Table of Components

No.	Description	Qty	Material and Remark
①	Pusher Plate	1	SS400
②	Connector Plate	1	SS400
③	Spring	2	SWPA $\phi 20 \times L20$
④	Hanger Bolt	2	SCM435 with Bushing

EX Example

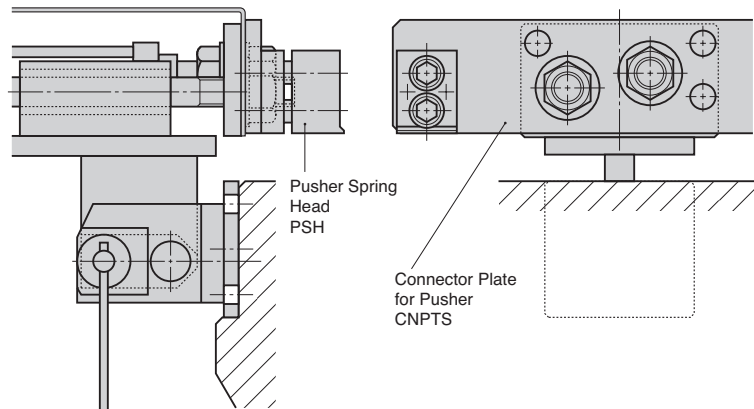

# Connector Plate

FOR PUSHER SPRING HEAD MOUNTING

CAD FILE

CNPTS (For APEH, P351)

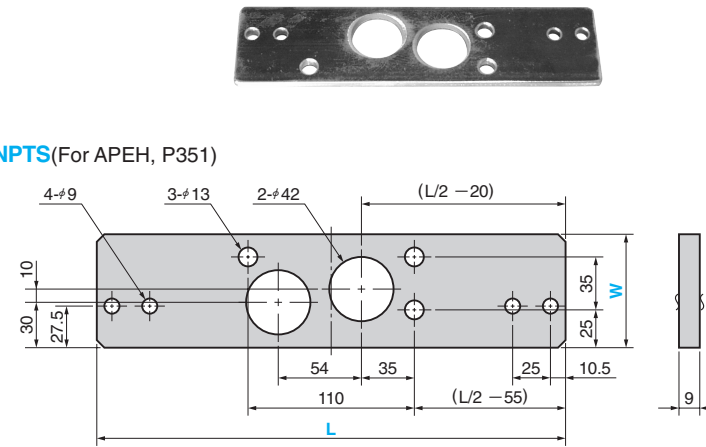

CNPT (For SOAP, P345)

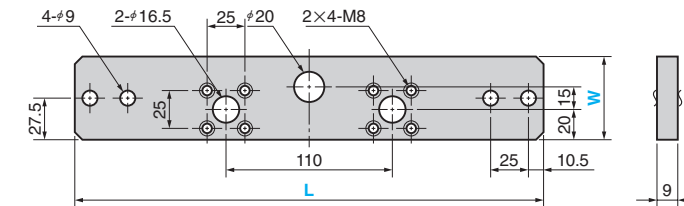

Material : SS400

Catalog No.	W	L Increments of 1 mm
		220 ~ 250
		251 ~ 300
		301 ~ 350
CNPTS	75	351 ~ 400
		401 ~ 450
		451 ~ 500
		501 ~ 550
		551 ~ 600

Catalog No.	W	L Increments of 1 mm
		250 ~ 300
		301 ~ 350
		351 ~ 400
CNPT	55	401 ~ 450
		451 ~ 500
		501 ~ 550
		551 ~ 600

Order   -

⚠ CNPTS and CNPT are made to order.

Panel Transfer Components