

Coil Support Spring Type

Blanking Die Components

SJPS (Light Load Type)
SJPX (Heavy Load Type)

**CAD
FILE**

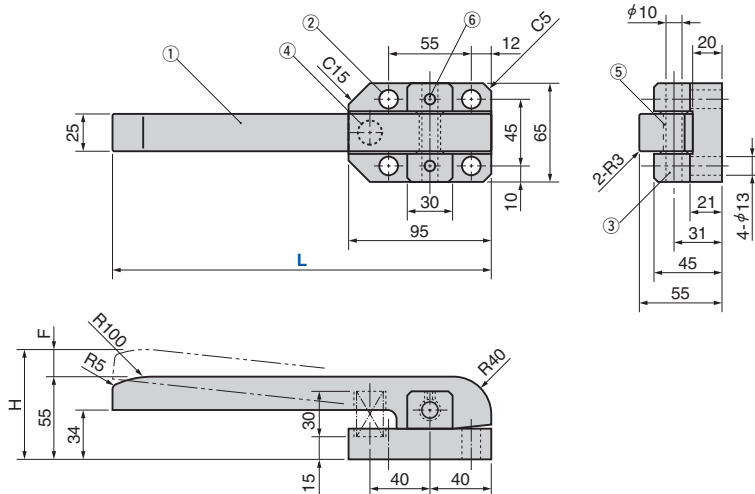

No.	Description	Qty	Material and Remark
1	Support Bar	1	SO-2
2	Base Plate	1	Cast Iron
3	Pin	1	Steel
4	Spring	1	φ17-40 (Light), φ16-40 (Heavy)
5	Bushing with Flange	2	BM1010F18
6	Hexagon Socket Set Screw	2	M6x8

Catalog No.	L	Spring load [N]		H	F	Weight kg
		Initial load	Final load			
SJPS	250	57	95	73.3	18.3	2.2
SJPX	250	240	400			



Order

Catalog No.

SJPS

L

250



Example

