

# Sheet Guide Roller Set

## Blanking Die Components

SGRT  
SGRR

CAD  
FILE



SGRT

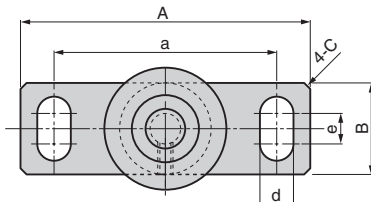

SGRR

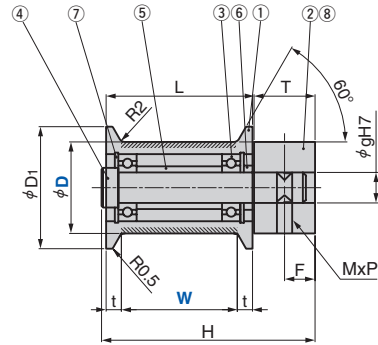
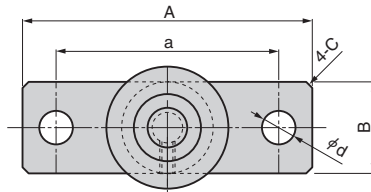

Hatched area to be  
Induction Hardened

No.	Description	Qty	Material and Remark
1	Roller	1	Steel
2	Base Plate	1	Steel
3	Bearing (Ball bearing)	2	See standard table below.
4	Roller Set Pin	1	Steel
5	Spacer for Bearing	1	STB
6	Spacer for Bearing	1	STB
7	C-shaped Snap Ring	2	—
8	Hexagon Socket Set Screw	1	—

Catalog No.	D	W	③ Bearing
SGRT	30	38	B6900ZZ
SGRR	55	70	B6004ZZ

D	W	A	a	B	C	d	e	D <sub>1</sub>	H	L	t	T	F	g	MxP
30	38	95	73	30	2	11	10	40	70	48	5	20	10	10	M5xP0.8
55	70	145	115	55	5	13	20	75	127	86	8	35	20	20	M8xP1.25



Order

Catalog No. **SGRT**    D **55** — W **70**