

# Cam Dwell Plate

30° Type

## Cam Slide Components

**CSPW**  
(Bronze with Graphite Type)

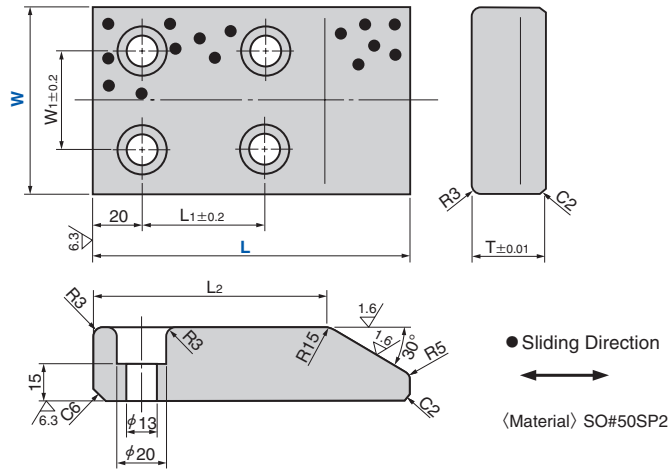

**CSPS** (Steel Type)

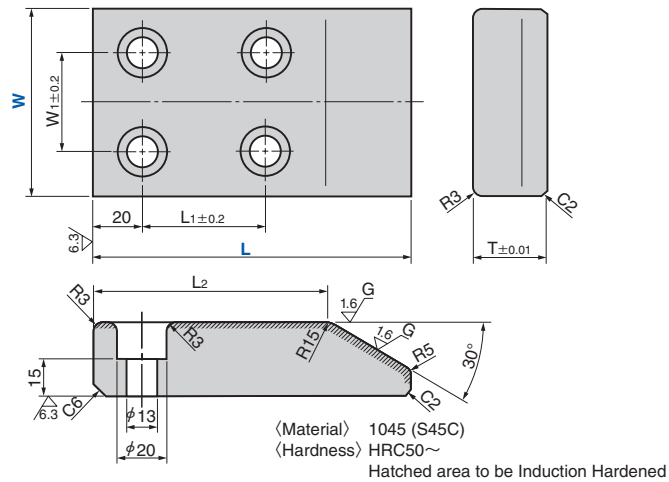

**CMCSA**

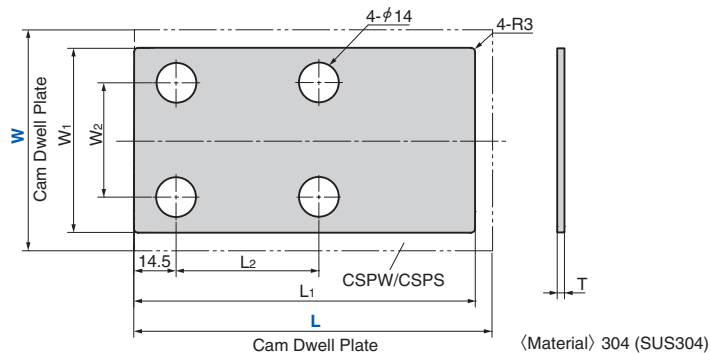

Catalog No.	W	L	T	W <sub>1</sub>	L <sub>1</sub>	L <sub>2</sub>
CSPW CSPS	75	130*1	30	40	50	95
		150*1	45		45	90
	100	130*1	30	60	50	95
		150*1	45		45	90
		170	60		75	120
		200	75		120	
125	130*1	30	85	50	95	
	150*1	45		45	90	
	170	60		45	90	
	130*1	30		50	95	
	150*1	45		45	90	
	170	60		75	120	
150	130*1	30	110	50	95	
	150*1	45		45	90	
	200	60		75	120	

\*1 There are shim plate for L=130, 150, see below.

● Sim Plate for CSPW/CSPS

Catalog No.	Nominal (Cam Dwell Plate)		Thick sheet T	W <sub>1</sub>	L <sub>1</sub>	W <sub>2</sub>	L <sub>2</sub>
	W	L					
CMCSA	75	130	0.05	65	120	40	50
		150			140		45
	100	130		90	120	60	50
		150			140		45
	125	130		115	120	85	50
		150			140		45
150	130	140	120	110	50		
150	140		45				

The order unit is one piece.



Catalog No.	W	-	L	-	T
CSPW	75	-	130	-	
CMCSA	75	-	130	-	0.1