

Cam Center Gib / Cam Center Block

Cam Slide Components

SFCU (Steel with Graphite Type)

CAD FILE

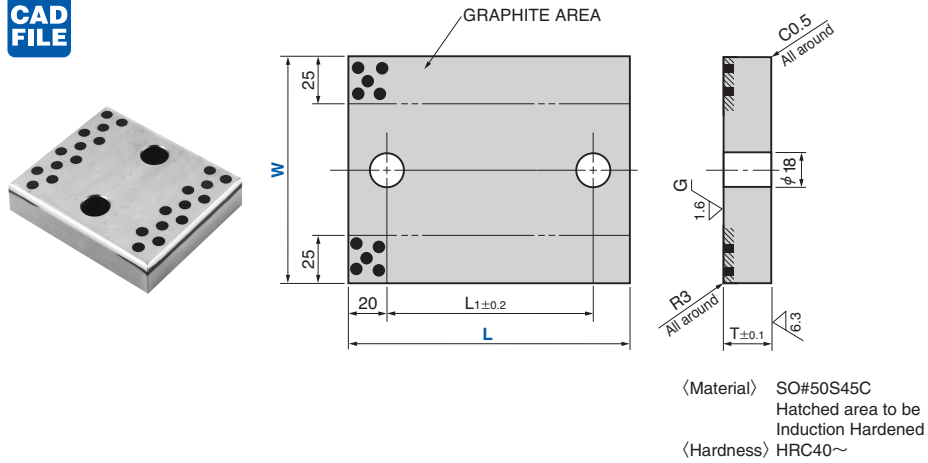

SFCX (Sintered Type)

CAD FILE

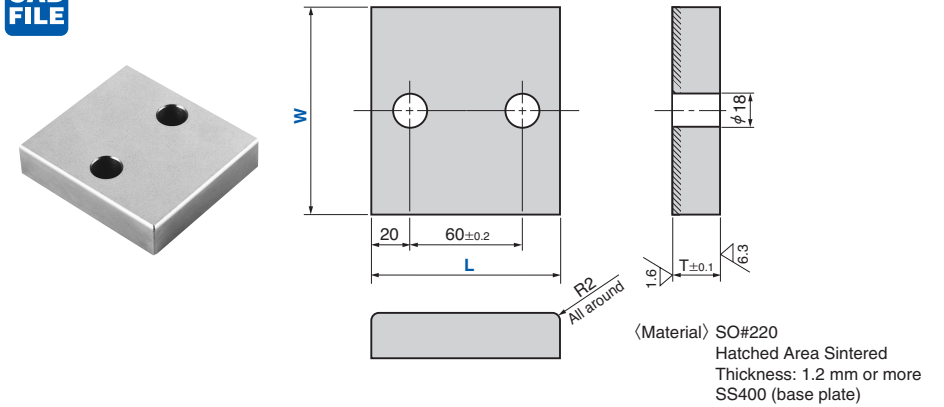

SFCUB

CAD FILE

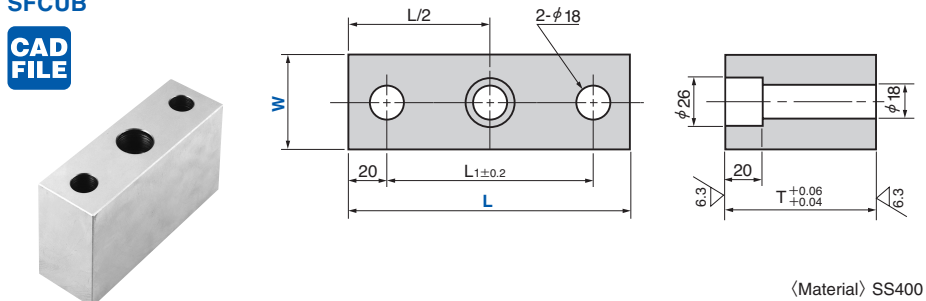

SFCXB

CAD FILE

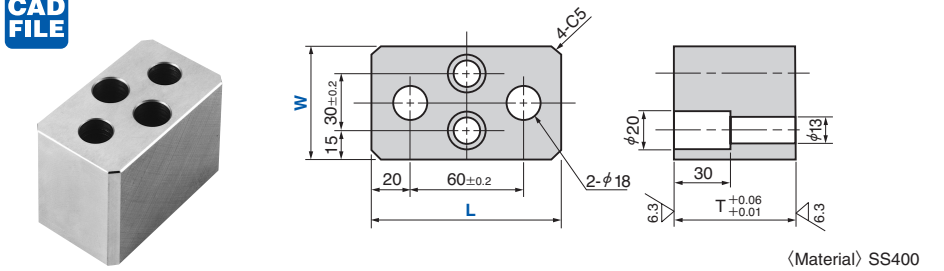

Catalog No.	W	L	T	L ₁
SFCU	120	100	25	60
		150		110
SFCUB	50	100	80	60
		150		110

Catalog No.	W	L	T
SFCX	110	100	25
SFCXB	60	100	65



Order

Catalog No.	W	-	L
SFCU	120	-	100



Order

Catalog No.	W	-	L
SFCX	110	-	100