

Cam Gib Plate

Cam Slide Components

SHCPA (Steel Lower Type)

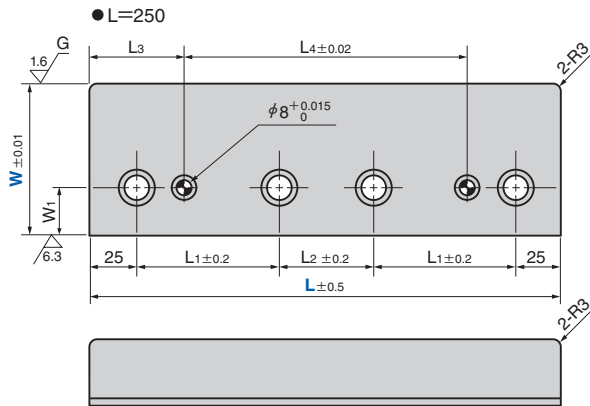
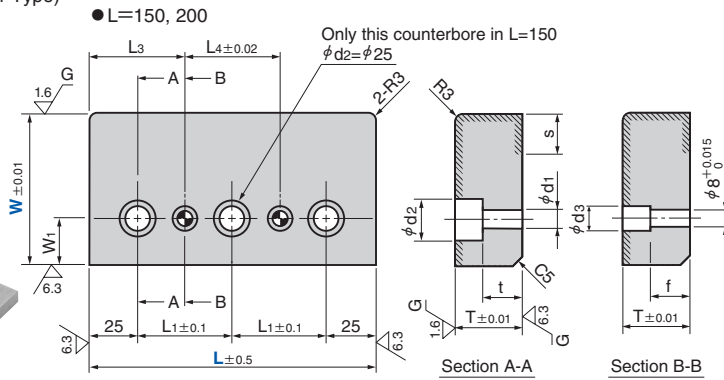
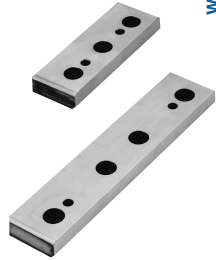

SHCP (Steel Side Type)

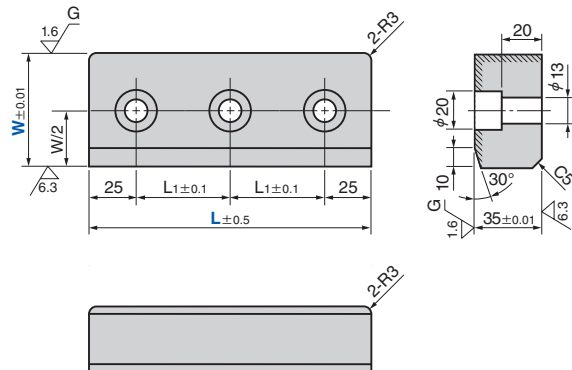

(Material) 1045 (S45C)
(Hardness) HRC50~
Hatched area to be
Induction Hardened

Catalog No.	W	L	T	L1	L2	L3	L4	W1	t	d1	d2	f	d3	s
	55	150	20	50	50	45	60	20	8	11	18	12		20
		200		110										
		250		160										
SHCPA	80	150	35	50	50	50	50	25	21	13	20		10	30
		200		100										
		250		150										
	95	150	50	50	50	55	40	35	32	18	25,26		9	35
		200		90										
		250		140										

Catalog No.	W	L	L1
SHCP	60	150	50
		200	75
		250	100

L size 250 of SHCPA and SHCP is made to order.



Catalog No.	W	L
SHCPA	55	150
SHCP	60	150



● Combination of cam side block MCSRG (page 149) and wear plate.

Cam Slide Plate SHCPA Thickness	MCSRG Thickness T	Wear Plate Thickness
20	30	
35	45	10
50	60	
20	40	
35	55	20
50	70	

