

# Inclined Pin Type with Cooling Hole

FOR KOCUMR & KOCUFR

RoHS

**KOPMR** (Adjusting Type)

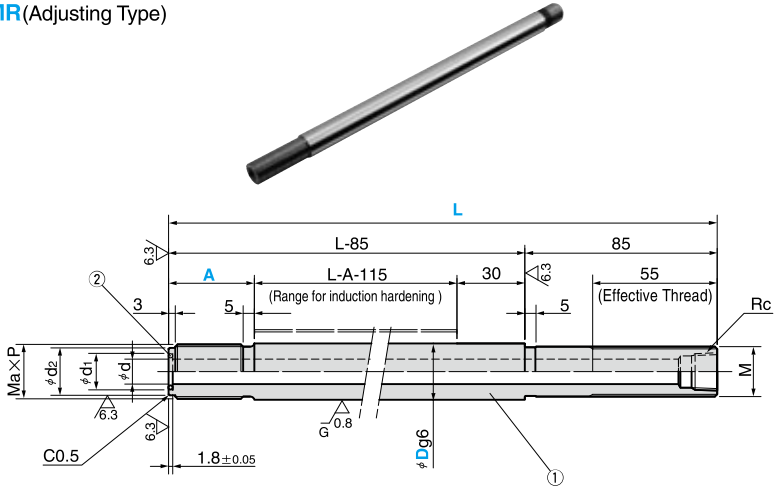

Induction hardening at  $\dashrightarrow$  HRC 56 to 60, Depth: 1 mm or more

**KOPFR** (Fixing Type)

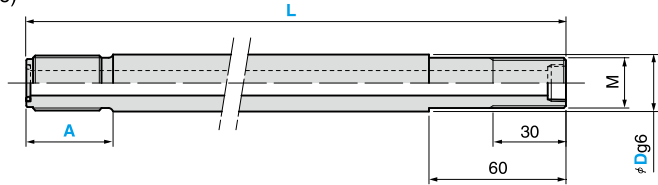

Material : ① SUJ 2 ② B1 ③ A 52100)

d	d1	d2	Ma×P	② O Ring	M	Rc	Catalog No.	D	L Increments of 0.1mm	A Increments of 1mm
12	17	20	M24×1.5	P12	M22×1.5	3/8	KOPMR	25	300 ≤ L ≤ 900	20 ≤ A ≤ 40
15	20	24	M28×1.5	P16	M27×1.5	1/2	KOPFR	30		



Order

Catalog No.	D	-	L	-	A
KOPMR	25	-	855.5	-	25
KOPFR	30	-	900.0	-	35

⚠ O ring is not attached

■ Built-in example

⚠ Please machine the detent after screwing in to core-block.

