

# Guide Pin For Large Die

BOLT TYPE

RoHS

RGPSB

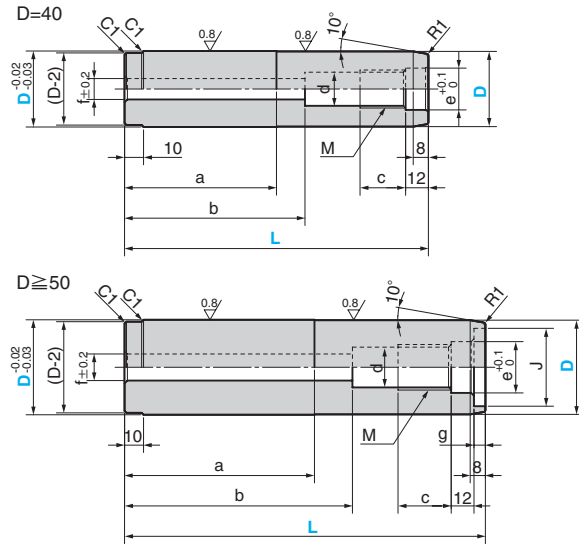

\*Hexagon bolt is included.

Material : S45C (T C45 A 1045)  
Hardness : HRC55~  
(Induction Hardened)

D tolerance	d	e	f	g	J	a	b	M×c	Accompanying Bolt
40	-0.04 -0.05	17.7	22	11	—	80	95	M20×24	M10×120
50	-0.06 -0.07	21.2	27	14	6	100	120	M24×28	M12×150
60	-0.07 -0.08	26.6	33	18	7.5	120	145	M30×33	M16×170
80	-0.08 -0.10	32.0	40	22	8.5	160	200	M36×43	M20×230

Catalog No.	D	L
RGPSB	40	160
	50	190
	60	230
	80	290

Order     -

# Assist Pin

FOR GUIDE PIN (RGPSB)

RoHS

SPGPB

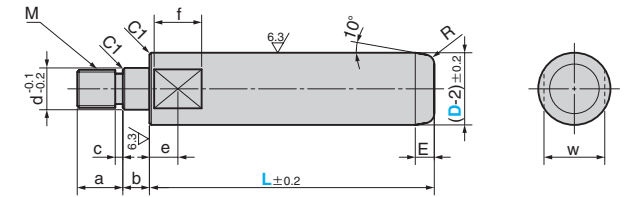

\*D is guide pin diameter.

Material : S45C (T C45 A 1045)  
Accessory : Spring Washer

d	a	b	c	e	f	M	E	R	w	Accompanying Washer	Catalog No.	D	L Increments of 10mm
22	20	14	4	15	25	M20	10	5	32	For M22	SPGPB	40	60 ~ 200
27	28	16	5	20	30	M24	12		41	For M27		50	80 ~ 250
33	30	18		25	35	M30	15	8	50	For M33		60	100 ~ 250
40	40		30	M36		10		70	For M42	80		120 ~ 300	

Order     -