

# Spherical Bushing Set

Rhomboid  
Flange Type

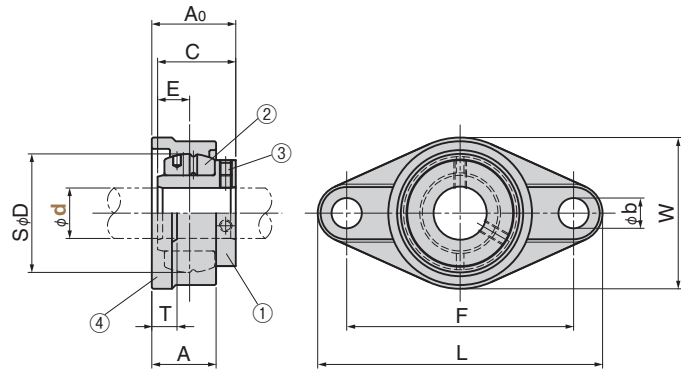

**Inner Ring Flange Bushing**  
**DUFBF** (Gray Cast Iron Case)  
**DUFBS** (Stainless steel case)



**Inner Ring Straight Bushing**  
**DUSBF** (Gray Cast Iron Case)  
**DUSBS** (Stainless steel case)

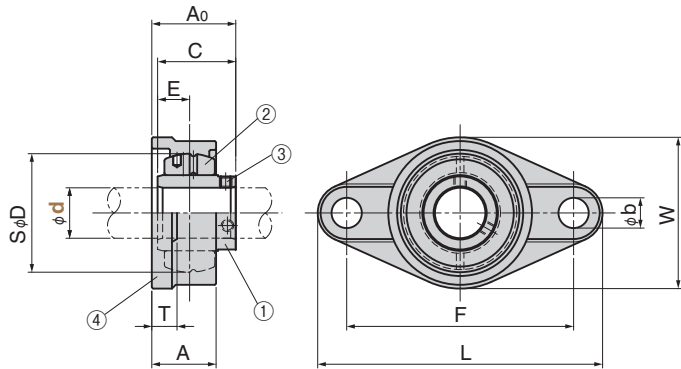

- ▲ Grease nipples are provided.
- ▲ Stopper pin for outer ring (SUJ2, 1pce) is attached.

### Table of Components

No.	Description	Qty	Material and remark
①	Inner Ring	1	S45CNon-electrolytic nickel plating
②	Outer ring	1	Copper alloy with graphite (SO#50SP2)
③	Hexagon socket head set screw	4	SCM435(Straight bush is 2)
④	Case	1	Gray cast iron(FC200) Stainless(SCS13)

A	A <sub>0</sub>	C	E	T	D	L	F	W	b	Mounting Bolt	Case No.	Catalog No.	d
25.5 (26)	33.3	31.0	12.7	11 (10)	47	113	90	60	12	M10	204		20
27 (27.5)	35.7	34.0	14.3	13 (10)	52	130	99	68			205		25
31	40.2	38.1	15.9	13 (10)	62	148	117	80	16	M14	206	Inner Ring Flange Bushing	30
34	44.4	42.9	17.5	14 (11)	72	161	130	90			207	DUFBF DUFBS Inner Ring Straight Bushing	35
36	51.2	49.2		14 (12)	80	175	144	100			208	DUSBF DUSBS	40
38	52.2	49.2	19.0	15 (13)	85	188	148	108	19	M16	209		45
40	54.6	51.6		15 (13)	90	197	157	115			210		50

\* Values in ( ) are for the stainless steel case.

Order    
**DUFBS** **40**

▲ The stainless steel case (DUFBS and DUSBS) are built-to-order product.