

●Features of SOUK

- High rigidity because of the box structure to keep the slider.
- 65, 100 and 200 are available for the mount width.
- Available angle is 0° to 70° at increments of 5°.
- Slider is removable from the back.

●Features of UCNBK

- High rigidity because of the box structure to keep the slider.
- Automatic alignment mechanism of the V-shaped guide.
- 65, 100 and 200 are available for the mount width.
- Available angle is 0° to 70° in increments of 10°. (mount width 65 is increments of 5°)
- Slider is removable from the back.

■Slide Structure and Positive Return Structure

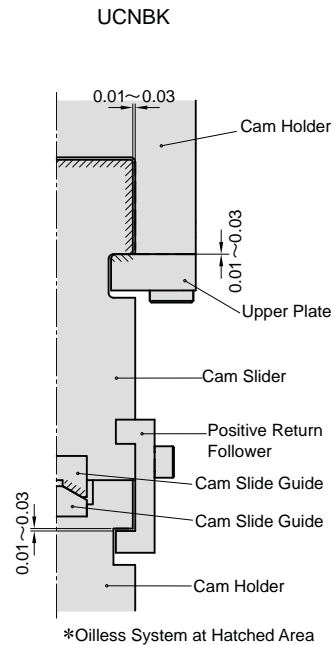
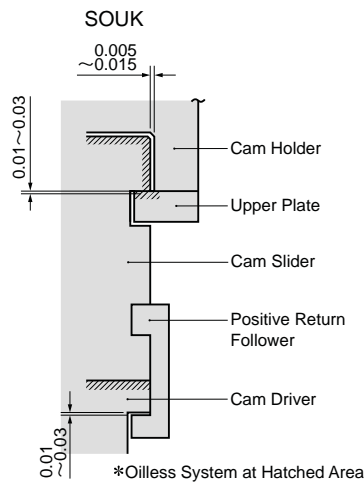

- The clearance between the cam holder and the cam slider is 0.005 to 0.015 at one side and has high rigidity.
- The clearance between the cam slider (positive return follower) and the cam driver is 0.01 to 0.03.

■SOUK Structure and Assembly / Disassembly

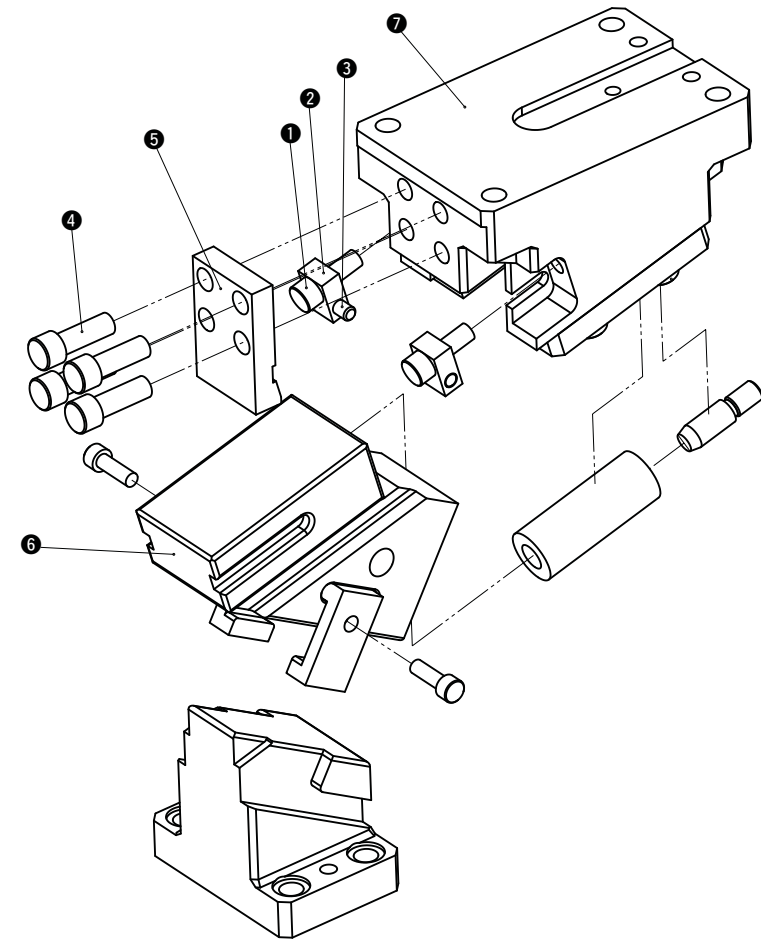

●Disassembly method of SOUK

- 1) Loosen hexagon socket head bolt (1) and remove plate (2) and dowel pin (3).
- 2) Loosen hexagon socket head bolt (4) and remove stopper (5).
- 3) Pull and remove cam slider (6) from cam holder (7) to the rear.

●Assembly method of SOUK

- 1) Assemble components in the reverse order of disassembly.
 - Make sure that there is no foreign matter on the sliding area and assemble components.
 - The clearance between the cam slider and the cam holder is controlled. Match the stamped serial number on the holder and slider before assembly.
 - When cam is disassembled and then reassembled, please do not forget to assemble all bolts provided.

■UCNBK Structure and Assembly / Disassembly

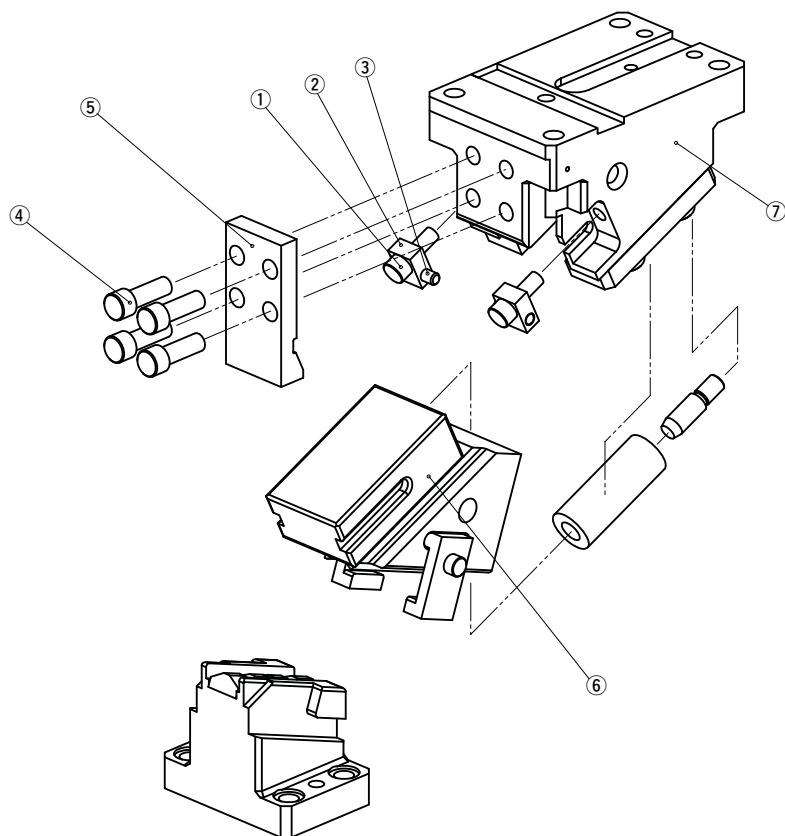

●Disassembly method of UCNBK

- 1) Loosen hexagon socket head bolt (14) and remove plate (12) and dowel pin (13).
- 2) Loosen hexagon socket head bolt (10) and remove stopper (6).
- 3) Pull and remove cam slider (1) from cam holder (5) to the rear.

●Assembly method of UCNBK

- 1) Assemble components in the reverse order of disassembly.
 - Make sure that there is no foreign matter on the sliding area and assemble components.
 - The clearance between the cam slider and the cam holder is controlled. Match the stamped serial number on the holder and slider before assembly.
 - When cam is disassembled and then reassembled, please do not forget to assemble all bolts provided.

■Option of SOUK/UCNBK

● Key Specification (-K)

SOUK65/100/200

LKU25-100 (with 1-M8 × 15 bolts)

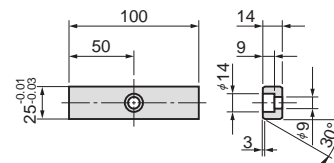

UCNBK65

LKU25-100 (with 2-M8 × 15 bolts)

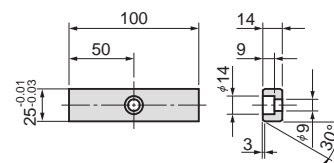

UCNBK100/200

LKU32-50 (with 3-M8 × 15 bolts)

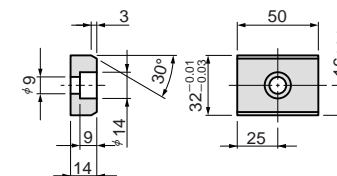

● Metric Key Specification (-KA)

UCNBK100/200

LKE25-32-50 (with 3-M8 × 15 bolts)

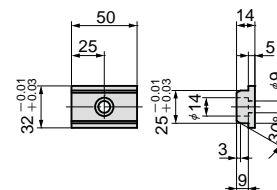

UCNBK200-10

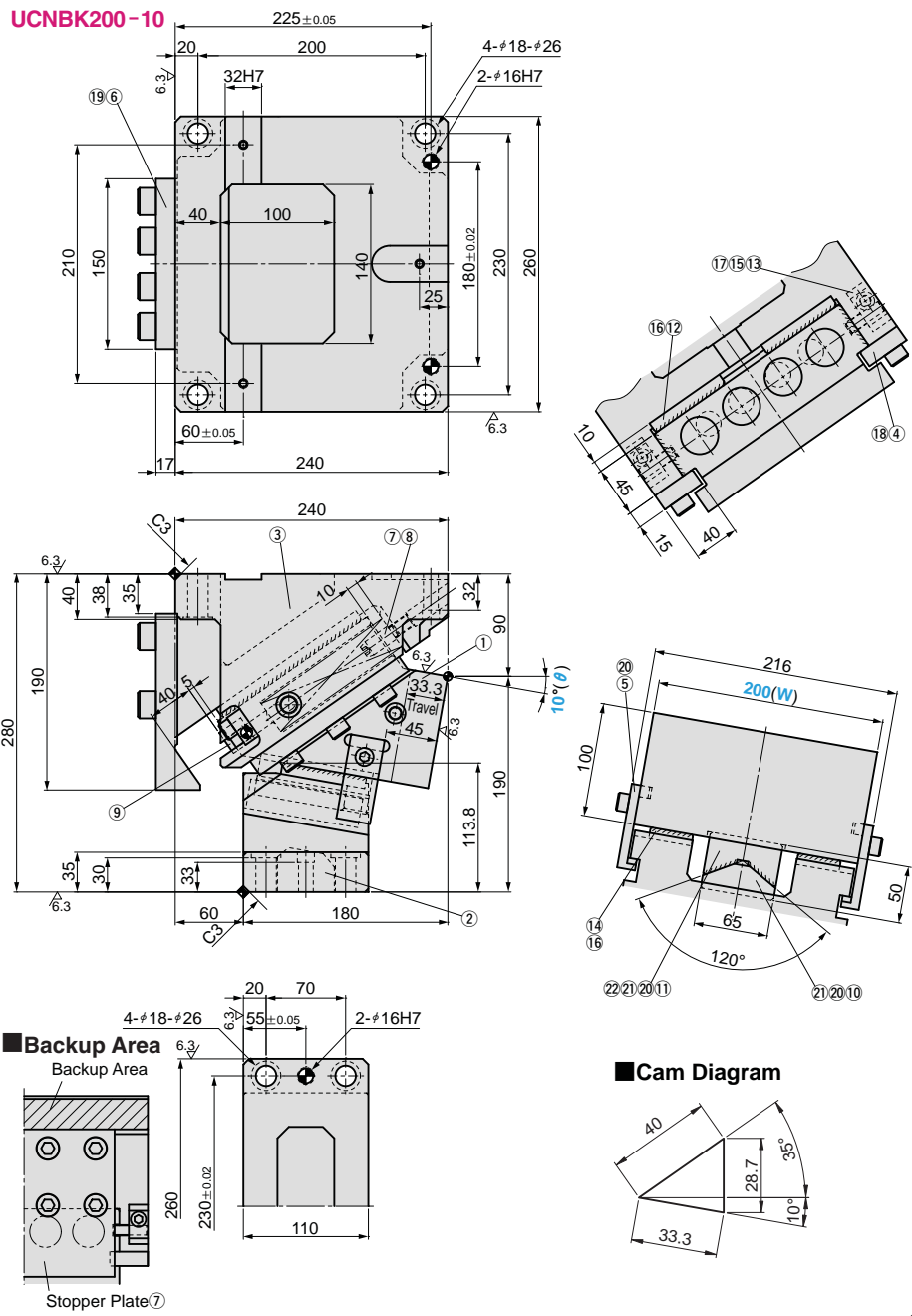

Travel S	Working Force kN(tonf)		Spring Force N(kgf)		Slider Weight kg	Catalog No.	(W)	(θ)
	Standard Working Force (one million strokes)	Allowable Working Force (300,000 strokes)	Initial Load	Final Load				
33.3	93.1 (9.5)	186.2 (19.0)	626.0 (63.9)	5634.0 (574.9)	24.8	UCNBK	200	10

Order **Catalog No.** (W) - (θ)
UCNBK 200 - 10

Option	Option Code	Specification
	K	A key for holder is attached. (It is not assembled to the main unit.)
	KA	Metric dedicated key is attached for cam holder. (It is not assembled to the main unit.)

For detailed specification of the key, refer to page 854.

Order **UCNBK200-10-K**

Refer to page 551 for detailed specifications of tapped holes and dowel pin holes(prepared hole,finish hole)for retainer.

Table of Components

No.	Description	Qty	Material and Remark
①	Cam Slider	1	FC250 with Graphite
②	Cam Driver	1	FC250
③	Cam Holder	1	FC250
④	Upper Plate	2	S45C with Graphite
⑤	Positive Return Follower	2	S45C(1045)
⑥	Stopper Plate	1	SS400(1020)
⑦	Spring Guide Pin	4	SCM435
⑧	Coil Spring	4	TM30×175
⑨	Stopper	4	Urethane
⑩	Cam Bottom Slide Plate	1	S45C(1045)
⑪	Cam Bottom Guide Plate	1	Bronze with Graphite(SO#50SP2)
⑫	Lower Plate	2	Bronze with Graphite(SO#50SP2)
⑬	Plate	2	S45C(1045)
⑭	Driver Plate	2	Bronze with Graphite(SO#50SP2)
⑮	Dowel Pin with Female Thread	2	SUJ2 #10×35
⑯	Hexagon Socket Brazier Head Bolt	8	SCM435 LCS10-20
⑰	Hexagon Socket Head Bolt	2	SCM435 M10×35
⑱	Hexagon Socket Head Bolt	6	SCM435 M12×35
⑲	Hexagon Socket Head Bolt	8	SCM435 M16×45
⑳	Hexagon Socket Head Bolt	6	SCM435 M10×30
㉑	Dowel Pin with Female Thread	4	SUJ2 #10×25
㉒	Screw Plug	2	S45C M12

Spring Diagram

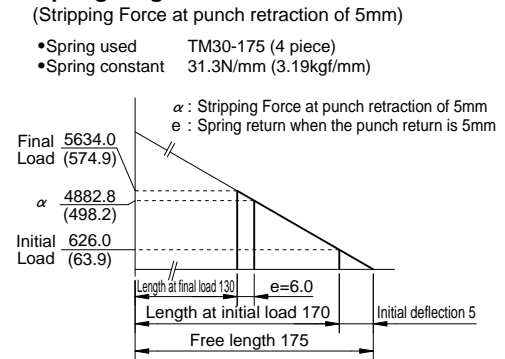

Space for removing

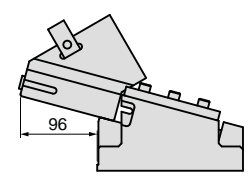

UCNBK200-20

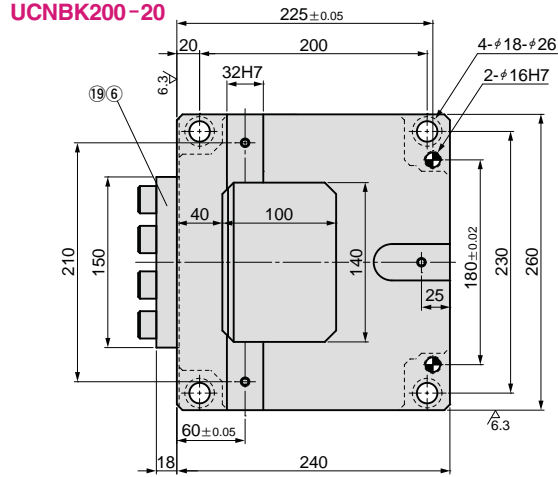

Cam Diagram

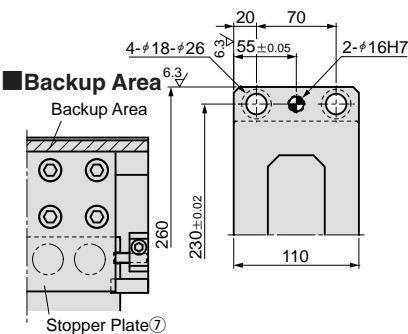
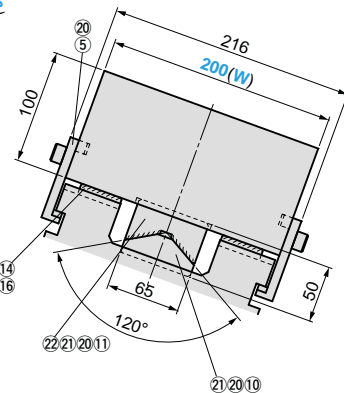
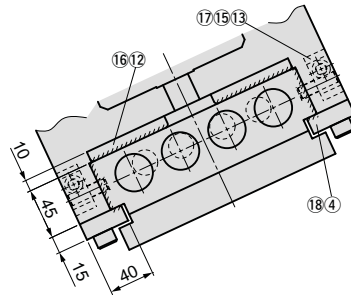
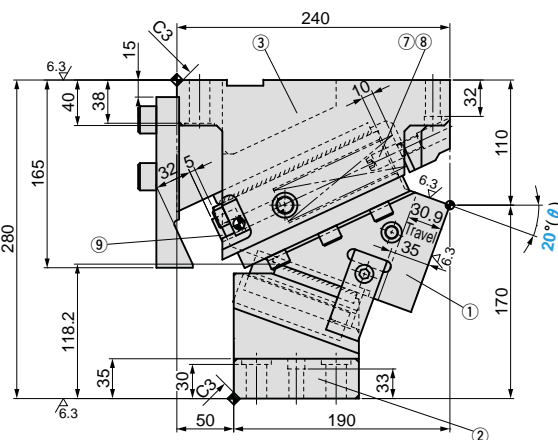
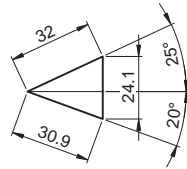

Travel S	Working Force kN(tonf)		Spring Force N(kgf)		Slider Weight kg	Catalog No.	(W)	(θ)
	Standard Working Force (one million strokes)	Allowable Working Force (300,000 strokes)	Initial Load	Final Load				
30.9	93.1 (9.5)	186.2 (19.0)	439.2 (44.8)	5124.0 (522.9)	25.9	UCNBK	200	20

Order **Catalog No.** (W) - (θ)
UCNBK 200 - 20

Option

Option Code	Specification
K	A key for holder is attached. (It is not assembled to the main unit.)
KA	Metric dedicated key is attached for cam holder. (It is not assembled to the main unit.)

For detailed specification of the key, refer to page 854.

Order **UCNBK200-20-K**

Refer to page 551 for detailed specifications of tapped holes and dowel pin holes(prepared hole,finish hole)for retainer.

Table of Components

No.	Description	Qty	Material and Remark
①	Cam Slider	1	FC250 with Graphite
②	Cam Driver	1	FC250
③	Cam Holder	1	FC250
④	Upper Plate	2	S45C with Graphite
⑤	Positive Return Follower	2	S45C(1045)
⑥	Stopper Plate	1	SS400(1020)
⑦	Spring Guide Pin	4	SCM435
⑧	Coil Spring	4	TM30×150
⑨	Stopper	4	Urethane
⑩	Cam Bottom Slide Plate	1	S45C(1045)
⑪	Cam Bottom Guide Plate	1	Bronze with Graphite(SO#50SP2)
⑫	Lower Plate	2	Bronze with Graphite(SO#50SP2)
⑬	Plate	2	S45C(1045)
⑭	Driver Plate	2	Bronze with Graphite(SO#50SP2)
⑮	Dowel Pin with Female Thread	2	SUJ2 #10×35
⑯	Hexagon Socket Brazier Head Bolt	8	SCM435 LCS10-20
⑰	Hexagon Socket Head Bolt	2	SCM435 M10×35
⑱	Hexagon Socket Head Bolt	6	SCM435 M12×35
⑲	Hexagon Socket Head Bolt	8	SCM435 M16×45
⑳	Hexagon Socket Head Bolt	6	SCM435 M10×30
㉑	Dowel Pin with Female Thread	4	SUJ2 #10×25
㉒	Screw Plug	2	S45C M12

Spring Diagram

(Stripping Force at punch retraction of 5mm)

- Spring used TM30-150 (4 piece)
- Spring constant 36.6N/mm (3.73kgf/mm)

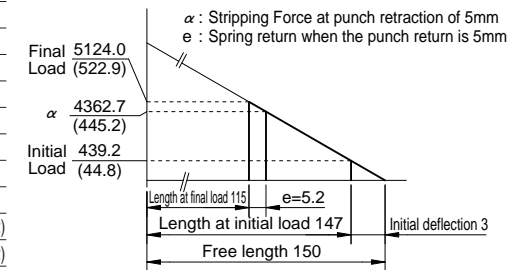

Space for removing

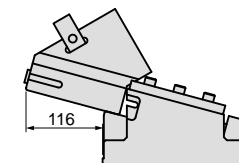

Aerial Cam Unit

FOR PIERCE AND FLANGE

NEW CAD FILE

UCNBK200-40

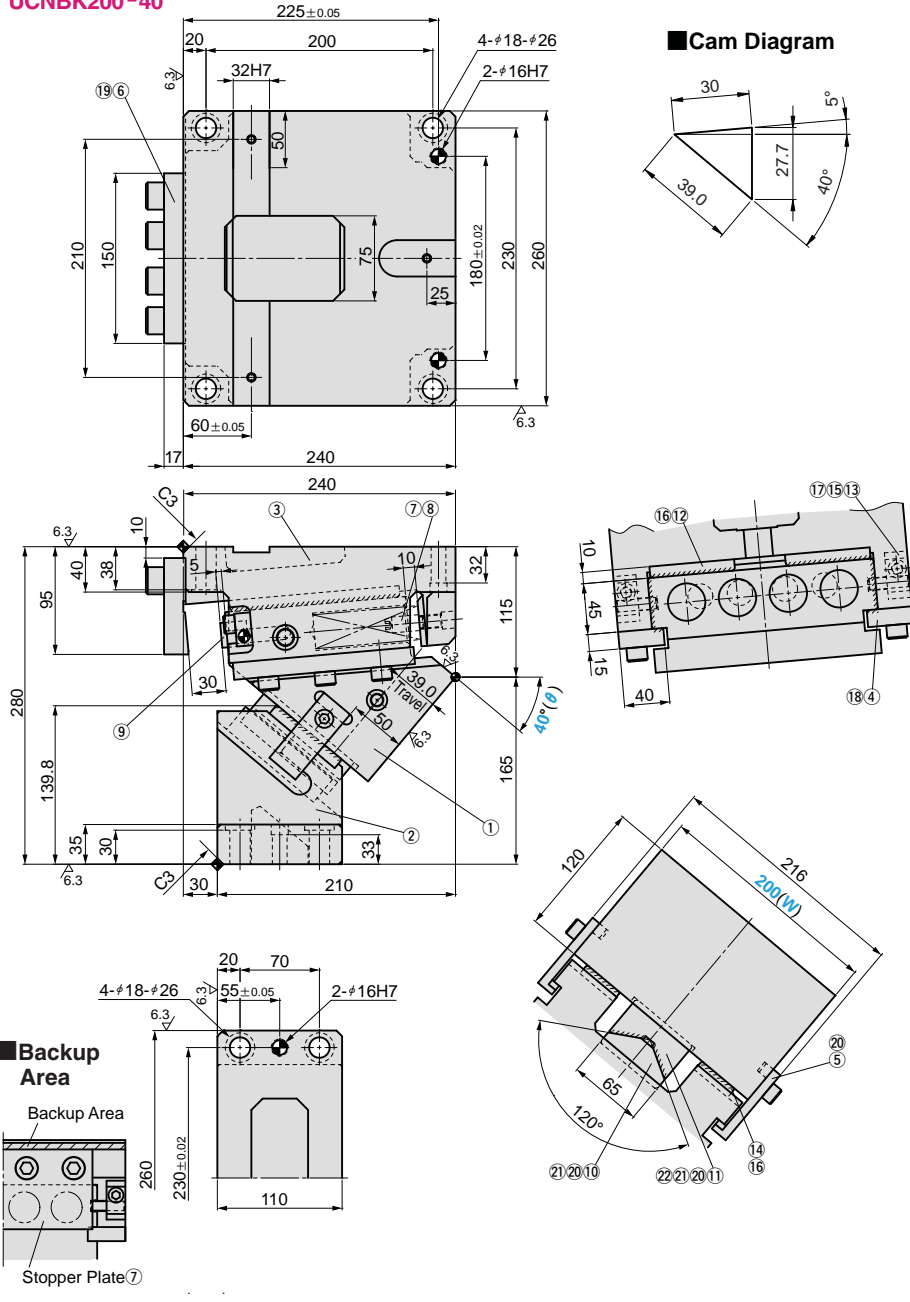

Travel S	Working Force kN(tonf)		Spring Force N(kgf)		Slider Weight kg	Catalog No.	(W)	(θ)
	Standard Working Force (one million strokes)	Allowable Working Force (300,000 strokes)	Initial Load	Final Load				
39.0	93.1 (9.5)	186.2 (19.0)	351.2 (35.8)	5619.2 (573.4)	30.2	UCNBK	200	40



Order

Catalog No. **UCNBK** (W) **200** - (θ) **40**



Option

Option Code	Specification
K	A key for holder is attached. (It is not assembled to the main unit.)
KA	Metric dedicated key is attached for cam holder. (It is not assembled to the main unit.)

For detailed specification of the key, refer to page 854.



Order

UCNBK200-40-K

Refer to page 551 for detailed specifications of tapped holes and dowel pin holes(prepared hole,finish hole)for retainer.

Table of Components

No.	Description	Qty	Material and Remark
①	Cam Slider	1	FC250 with Graphite
②	Cam Driver	1	FC250
③	Cam Holder	1	FC250
④	Upper Plate	2	S45C with Graphite
⑤	Positive Return Follower	2	S45C(1045)
⑥	Stopper Plate	1	SS400(1020)
⑦	Spring Guide Pin	4	SCM435
⑧	Coil Spring	4	TM30×125
⑨	Stopper	4	Urethane
⑩	Cam Bottom Slide Plate	1	S45C(1045)
⑪	Cam Bottom Guide Plate	1	Bronze with Graphite(SO#50SP2)
⑫	Lower Plate	2	Bronze with Graphite(SO#50SP2)
⑬	Plate	2	S45C(1045)
⑭	Driver Plate	2	Bronze with Graphite(SO#50SP2)
⑮	Dowel Pin with Female Thread	2	SUJ2 #10×35
⑯	Hexagon Socket Brazier Head Bolt	8	SCM435 LCS10-20
⑰	Hexagon Socket Head Bolt	2	SCM435 M10×35
⑱	Hexagon Socket Head Bolt	6	SCM435 M12×35
⑲	Hexagon Socket Head Bolt	4	SCM435 M16×45
⑳	Hexagon Socket Head Bolt	6	SCM435 M10×30
㉑	Dowel Pin with Female Thread	4	SUJ2 #10×25
㉒	Screw Plug	2	S45C M12

Spring Diagram

(Stripping Force at punch retraction of 5mm)

- Spring used TM30-125 (4 piece)
- Spring constant 43.9N/mm (4.48kgf/mm)

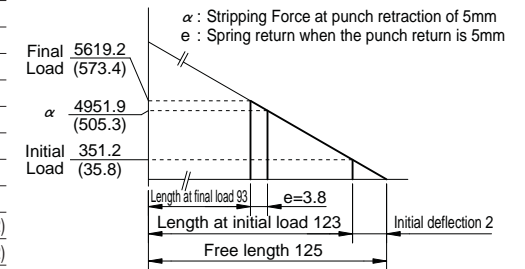

Space for removing

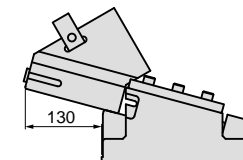

UCNBK200-50

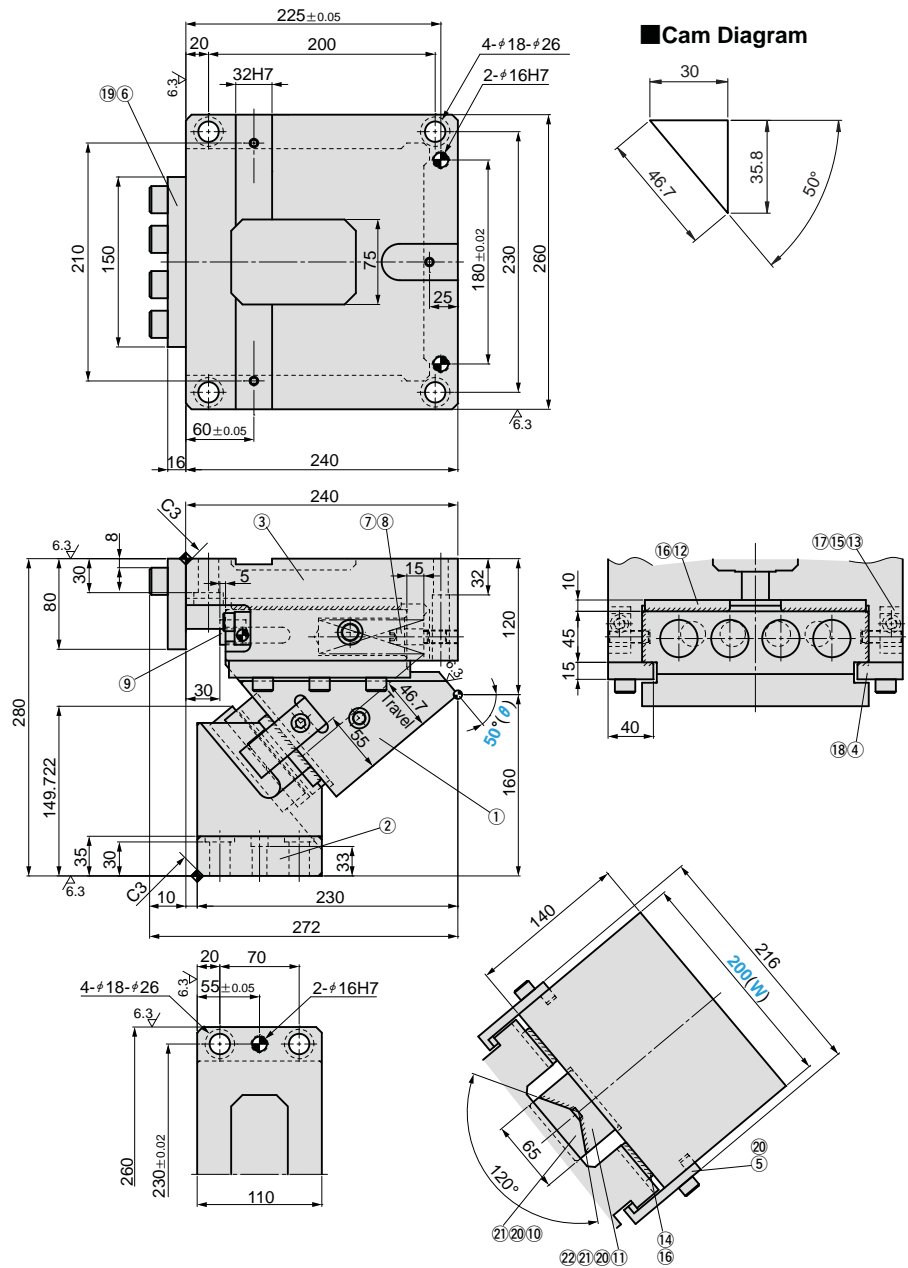

Travel S	Working Force kN(tonf)		Spring Force N(kgf)		Slider Weight kg	Catalog No.	(W)	(θ)
	Standard Working Force (one million strokes)	Allowable Working Force (300,000 strokes)	Initial Load	Final Load				
46.7	93.1 (9.5)	186.2 (19.0)	351.2 (35.8)	5619.2 (573.4)	32.4	UCNBK	200	50

Order **Catalog No.** (W) - (θ)
UCNBK 200 - 50

Option	Option Code	Specification
	K	A key for holder is attached. (It is not assembled to the main unit.)
	KA	Metric dedicated key is attached for cam holder. (It is not assembled to the main unit.)

For detailed specification of the key, refer to page 854.

Order **UCNBK200-50-K**

Refer to page 551 for detailed specifications of tapped holes and dowel pin holes(prepared hole,finish hole)for retainer.

Table of Components

No.	Description	Qty	Material and Remark
①	Cam Slider	1	FC250 with Graphite
②	Cam Driver	1	FC250
③	Cam Holder	1	FC250
④	Upper Plate	2	S45C with Graphite
⑤	Positive Return Follower	2	S45C(1045)
⑥	Stopper Plate	1	SS400(1020)
⑦	Spring Guide Pin	4	SCM435
⑧	Coil Spring	4	TM30×125
⑨	Stopper	4	Urethane
⑩	Cam Bottom Slide Plate	1	S45C(1045)
⑪	Cam Bottom Guide Plate	1	Bronze with Graphite(SO#50SP2)
⑫	Lower Plate	2	Bronze with Graphite(SO#50SP2)
⑬	Plate	2	S45C(1045)
⑭	Driver Plate	2	Bronze with Graphite(SO#50SP2)
⑮	Dowel Pin with Female Thread	2	SUJ2 #10×35
⑯	Hexagon Socket Brazier Head Bolt	8	SCM435 LCS10-20
⑰	Hexagon Socket Head Bolt	2	SCM435 M10×35
⑱	Hexagon Socket Head Bolt	6	SCM435 M12×35
⑲	Hexagon Socket Head Bolt	4	SCM435 M16×45
⑳	Hexagon Socket Head Bolt	6	SCM435 M10×30
㉑	Dowel Pin with Female Thread	4	SUJ2 #10×25
㉒	Screw Plug	2	S45C M12

Spring Diagram

(Stripping Force at punch retraction of 5mm)

- Spring used TM30-125 (4 piece)
- Spring constant 43.9N/mm (4.48kgf/mm)

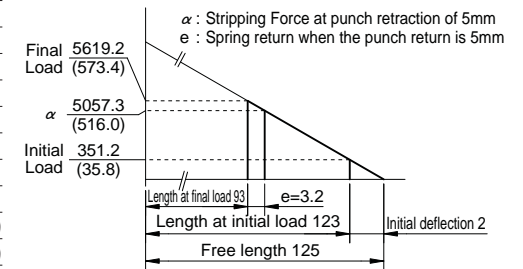

Space for removing

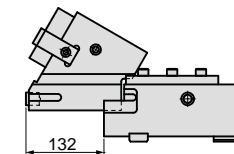

UCNBK200-60

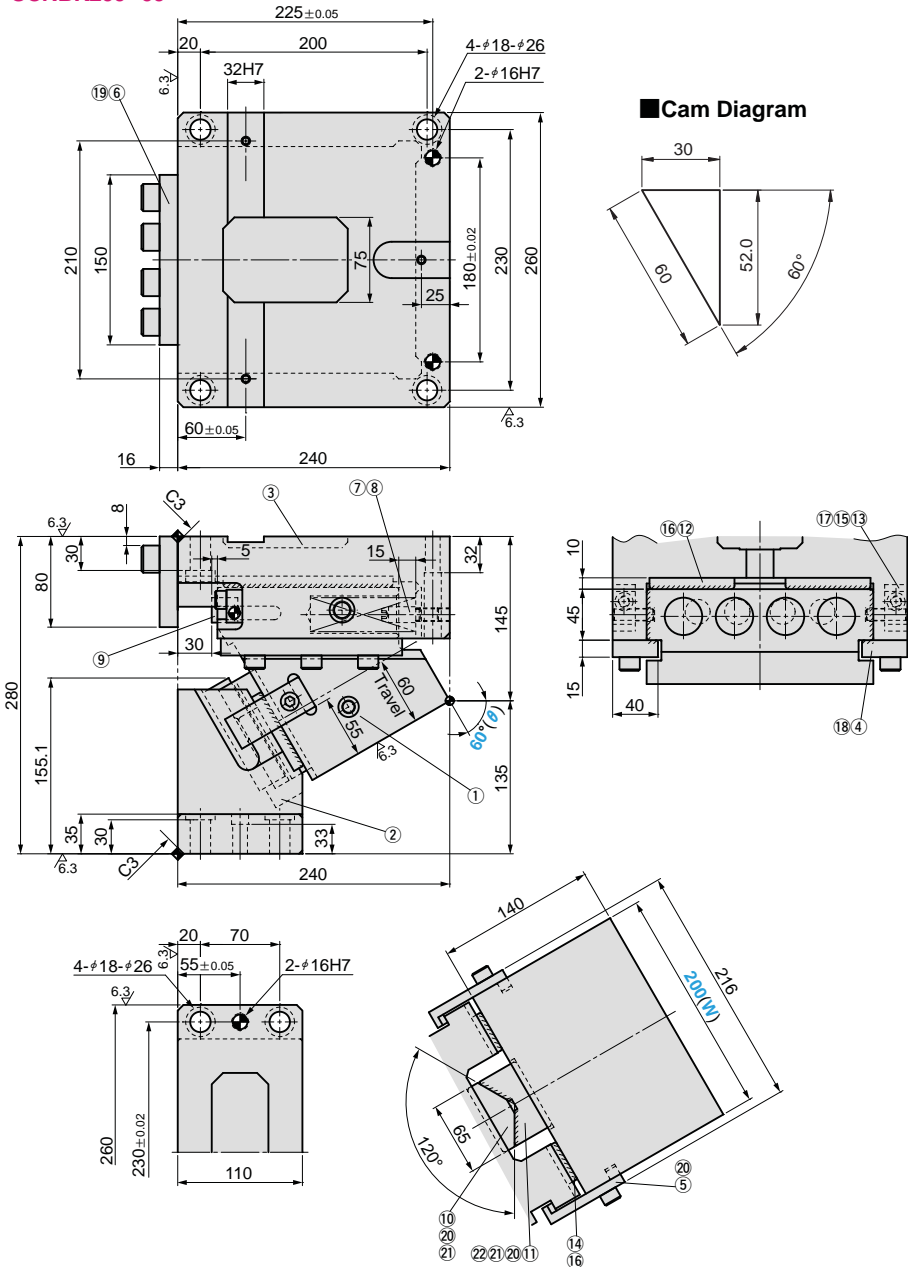

Travel S	Working Force kN(tonf)		Spring Force N(kgf)		Slider Weight kg	Catalog No.	(W)	(θ)
	Standard Working Force (one million strokes)	Allowable Working Force (300,000 strokes)	Initial Load	Final Load				
60.0	93.1 (9.5)	186.2 (19.0)	351.2 (35.8)	5619.2 (573.4)	33.5	UCNBK	200	60

Order **Catalog No.** **(W)** - **(θ)**
UCNBK 200 - 60

Option	Option Code	Specification
	K	A key for holder is attached. (It is not assembled to the main unit.)
	KA	Metric dedicated key is attached for cam holder. (It is not assembled to the main unit.)

For detailed specification of the key, refer to page 854.

Order **UCNBK200 - 60 - K**

Refer to page 551 for detailed specifications of tapped holes and dowel pin holes(prepared hole,finish hole)for retainer.

Table of Components

No.	Description	Qty	Material and Remark
①	Cam Slider	1	FC250 with Graphite
②	Cam Driver	1	FC250
③	Cam Holder	1	FC250
④	Upper Plate	2	S45C with Graphite
⑤	Positive Return Follower	2	S45C(1045)
⑥	Stopper Plate	1	SS400(1020)
⑦	Spring Guide Pin	4	SCM435
⑧	Coil Spring	4	TM30×125
⑨	Stopper	4	Urethane
⑩	Cam Bottom Slide Plate	1	S45C(1045)
⑪	Cam Bottom Guide Plate	1	Bronze with Graphite(SO#50SP2)
⑫	Lower Plate	2	Bronze with Graphite(SO#50SP2)
⑬	Plate	2	S45C(1045)
⑭	Driver Plate	2	Bronze with Graphite(SO#50SP2)
⑮	Dowel Pin with Female Thread	2	SUJ2 φ10×35
⑯	Hexagon Socket Brazier Head Bolt	8	SCM435 LCS10-20
⑰	Hexagon Socket Head Bolt	2	SCM435 M10×35
⑱	Hexagon Socket Head Bolt	6	SCM435 M12×35
⑲	Hexagon Socket Head Bolt	4	SCM435 M16×45
⑳	Hexagon Socket Head Bolt	6	SCM435 M10×30
㉑	Dowel Pin with Female Thread	4	SUJ2 φ10×25
㉒	Screw Plug	2	S45C M12

Spring Diagram

(Stripping Force at punch retraction of 5mm)

- Spring used TM30-125 (4 piece)
- Spring constant 43.9N/mm (4.48kgf/mm)

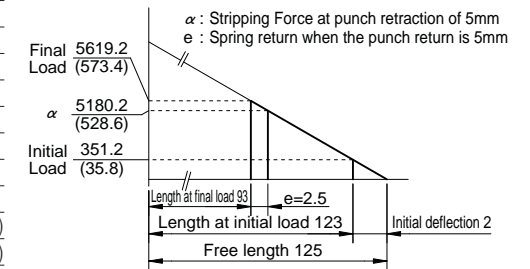

Space for removing

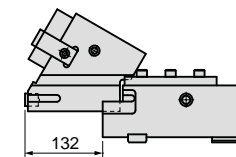

UCNBK200-70

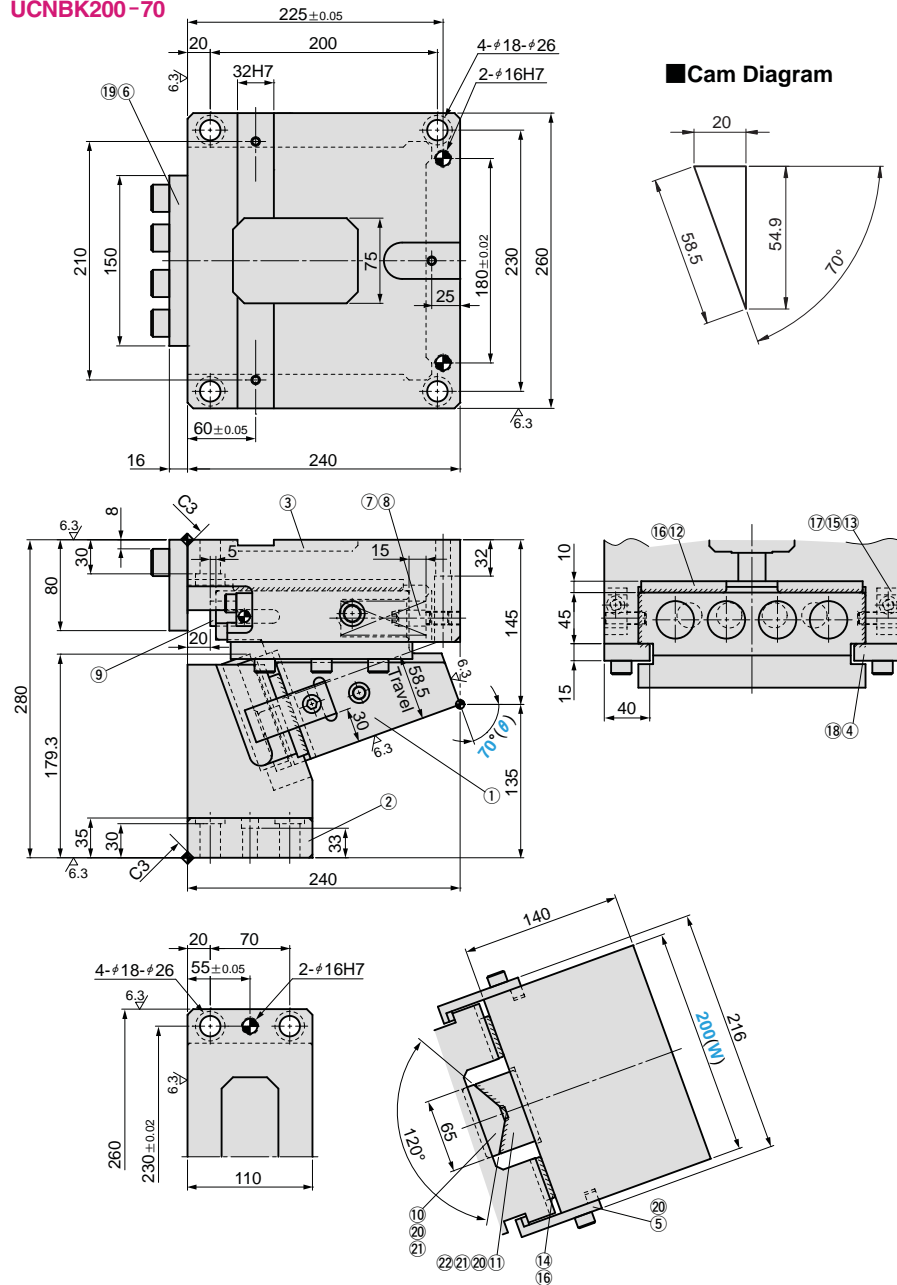

Travel S	Working Force kN(tonf)		Spring Force N(kgf)		Slider Weight kg	Catalog No.	(W)	(θ)
	Standard Working Force (one million strokes)	Allowable Working Force (300,000 strokes)	Initial Load	Final Load				
58.5	93.1 (9.5)	186.2 (19.0)	1096.0 (111.8)	5480.0 (559.2)	30.2	UCNBK	200	70

Order **Catalog No.** **(W)** - **(θ)**
UCNBK 200 - 70

Option	Option Code	Specification
	K	A key for holder is attached. (It is not assembled to the main unit.)
	KA	Metric dedicated key is attached for cam holder. (It is not assembled to the main unit.)

For detailed specification of the key, refer to page 854.

Order **UCNBK200-70-K**

Refer to page 551 for detailed specifications of tapped holes and dowel pin holes(prepared hole,finish hole)for retainer.

Table of Components

No.	Description	Qty	Material and Remark
①	Cam Slider	1	FC250 with Graphite
②	Cam Driver	1	FC250
③	Cam Holder	1	FC250
④	Upper Plate	2	S45C with Graphite
⑤	Positive Return Follower	2	S45C(1045)
⑥	Stopper Plate	1	SS400(1020)
⑦	Spring Guide Pin	4	SCM435
⑧	Coil Spring	4	TM30×100
⑨	Stopper	4	Urethane
⑩	Cam Bottom Slide Plate	1	S45C(1045)
⑪	Cam Bottom Guide Plate	1	Bronze with Graphite(SO#50SP2)
⑫	Lower Plate	2	Bronze with Graphite(SO#50SP2)
⑬	Plate	2	S45C(1045)
⑭	Driver Plate	2	Bronze with Graphite(SO#50SP2)
⑮	Dowel Pin with Female Thread	2	SUJ2 φ10×35
⑯	Hexagon Socket Brazier Head Bolt	8	SCM435 LCS10-20
⑰	Hexagon Socket Head Bolt	2	SCM435 M10×35
⑱	Hexagon Socket Head Bolt	6	SCM435 M12×35
⑲	Hexagon Socket Head Bolt	4	SCM435 M16×45
⑳	Hexagon Socket Head Bolt	6	SCM435 M10×30
㉑	Dowel Pin with Female Thread	4	SUJ2 φ10×25
㉒	Screw Plug	2	S45C M12

Spring Diagram

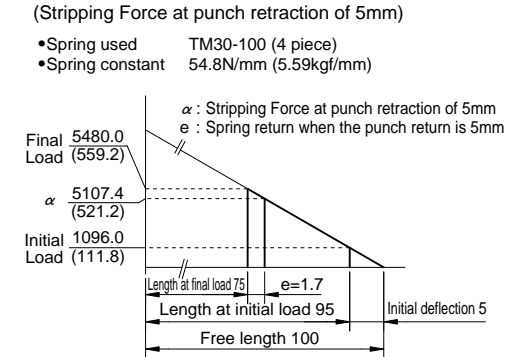

Space for removing

