

# Oilless Slide Guide Bronze L-Shaped Type

SO#50SP2

RoHS

**SGLDW**

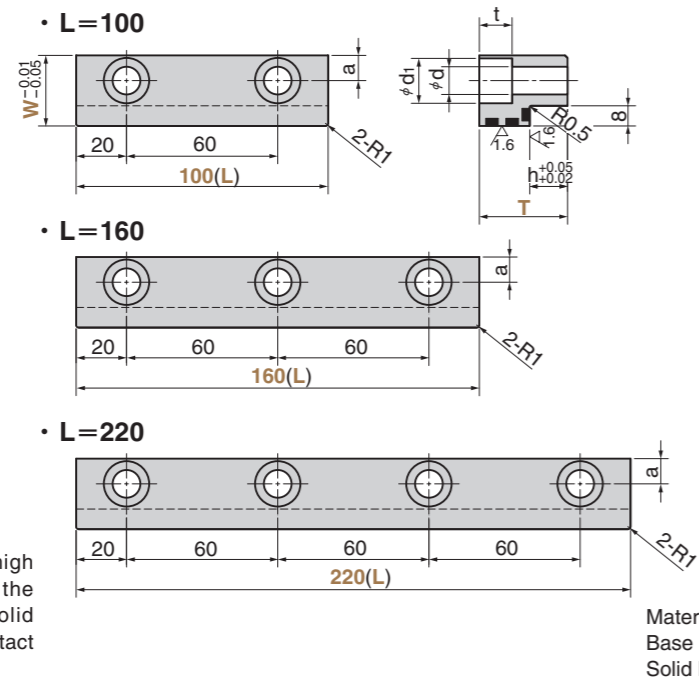

⚠ When the product is used at high temperature (150°C or more), the embedding specification of solid lubricant is different. Please contact us for details.

■ Operation Range

| Lubricant Type | Lubricating Condition       | Environment Condition | Max. Allowable Load P<br>N/mm <sup>2</sup> | Max. Allowable Sliding Speed V<br>m/min | Max. Allowable PV value<br>N/mm <sup>2</sup> ·m/min | Operation Range Temperature<br>°C |
|----------------|-----------------------------|-----------------------|--|---|---|-----------------------------------|
| GR-1           | No lubrication              | Atmosphere            | 100  | 15                                      | 150   | -50~+300                          |
|                | Regular lubrication(Grease) |                       |  | 30                                      | 200   | -50~+150                          |

■ Physical Properties

| Specific Gravity<br>g/cm <sup>3</sup> | Hardness<br>HB | Elongation<br>% | Tensile Strength<br>N/mm <sup>2</sup> | Linear Expansion Coefficient<br>×10 <sup>-7</sup> /°C |
|---------------------------------------|----------------|-----------------|---------------------------------------|---|
| 7.9                                   | 210 or more    | 12 or more      | 755 or more                           | 1.9   |

| a   | d  | d <sub>1</sub> | h  | t  | Catalog No. | W  | L   | T  |
|-----|----|----------------|----|----|-------------|----|-----|----|
| 7.5 | 7  | 11             | 15 | 7  | SGLDW       | 23 | 100 | 30 |
|     |    |                |    |    |             |    | 160 |    |
|     |    |                |    |    |             |    | 220 |    |
|     |    |                | 26 |    |             |    | 100 | 41 |
|     |    |                |    |    |             |    | 160 |    |
|     |    |                |    |    |             |    | 220 |    |
| 10  | 11 | 18             | 10 | 13 | SGLDW       | 28 | 100 | 25 |
|     |    |                |    |    |             |    | 160 |    |
|     |    |                |    |    |             |    | 220 |    |
|     |    |                | 26 |    |             |    | 100 | 35 |
|     |    |                |    |    |             |    | 160 |    |
|     |    |                |    |    |             |    | 220 |    |
|     |    |                | 26 |    | SGLDW       |    | 100 | 56 |
|     |    |                |    |    |             |    | 160 |    |
|     |    |                |    |    |             |    | 220 |    |

Order **Catalog No.** **W** - **L** - **T**  
SGLDW 23 - 220 - 30

■ We are ready to accept requests or orders for special parts.

# Oilless Slide Guide Bronze T-Shaped Type

SO#50SP2

RoHS

**TGLWN**

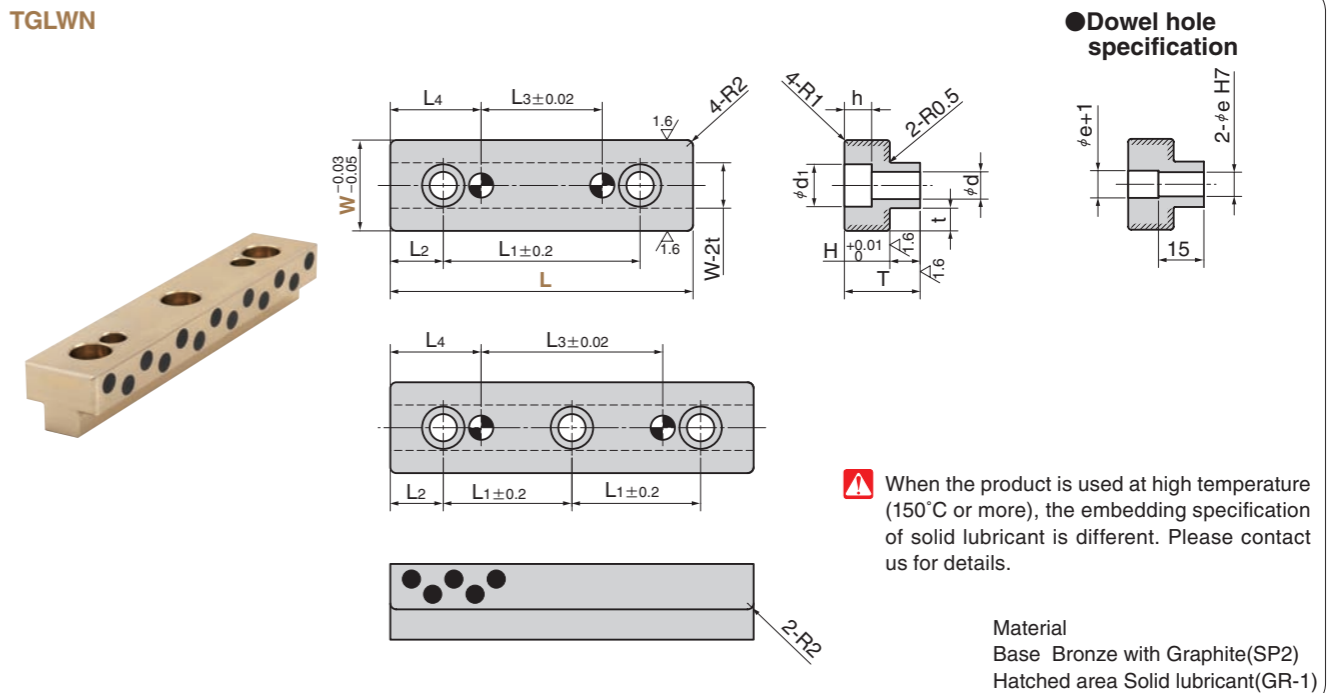

⚠ When the product is used at high temperature (150°C or more), the embedding specification of solid lubricant is different. Please contact us for details.

■ Operation Range

| Lubricant Type | Lubricating Condition       | Environment Condition | Max. Allowable Load P<br>N/mm <sup>2</sup> | Max. Allowable Sliding Speed V<br>m/min | Max. Allowable PV value<br>N/mm <sup>2</sup> ·m/min | Operation Range Temperature<br>°C |
|----------------|-----------------------------|-----------------------|--|---|---|-----------------------------------|
| GR-1           | No lubrication              | Atmosphere            | 100  | 15                                      | 150   | -50~+300                          |
|                | Regular lubrication(Grease) |                       |  | 30                                      | 200   | -50~+150                          |

■ Physical Properties

| Specific Gravity<br>g/cm <sup>3</sup> | Hardness<br>HB | Elongation<br>% | Tensile Strength<br>N/mm <sup>2</sup> | Linear Expansion Coefficient<br>×10 <sup>-7</sup> /°C |
|---------------------------------------|----------------|-----------------|---------------------------------------|---|
| 7.9                                   | 210 or more    | 12 or more      | 755 or more                           | 1.9   |

| L <sub>1</sub> | L <sub>2</sub> | L <sub>3</sub> | L <sub>4</sub> | T  | H  | t   | d   | d <sub>1</sub> | h  | Catalog No. | W   | L   |     |
|----------------|----------------|----------------|----------------|----|----|-----|-----|----------------|----|-------------|-----|-----|-----|
| 35             |                | 15             |                |    |    |     |     |                |    | TGLWN       | 20  | 60  |     |
| 55             | 12.5           | 35             | 22.5           | 15 |    | 4.5 | 5.5 | 9.5            | 6  |             |     | 80  |     |
| 75             |                | 55             |                |    | 8  |     |     |                |    |             |     | 100 |     |
| 50             |                | 20             |                |    |    |     |     |                |    |             |     | 80  |     |
| 70             | 15             | 40             |                | 20 |    | 5.5 | 6.5 | 11             | 7  |             |     | 25  | 100 |
| 45             |                | 60             | 30             |    |    |     |     |                |    |             |     | 120 |     |
| 65             |                | 40             |                |    |    |     |     |                |    | 100         |     |     |     |
| 42.5           | 17.5           | 60             |                | 25 | 10 | 7.5 | 9   | 14             | 9  | 30          | 120 |     |     |
| 52.5           |                | 80             |                |    |    |     |     |                |    | 140         |     |     |     |
| 40             |                | 40             |                |    |    |     |     |                |    | 120         |     |     |     |
| 50             |                | 60             | 40             | 30 | 15 | 11  | 11  | 18             | 11 | 40          | 140 |     |     |
| 60             | 20             | 80             |                |    |    |     |     |                |    | 160         |     |     |     |
| 70             |                | 100            |                |    |    |     |     |                |    | 180         |     |     |     |

Order **Catalog No.** **W** - **L**  
TGLWN 20 - 100

| W       | e | H7          |
|---------|---|-------------|
| 20 · 25 | 6 | +0.012<br>0 |
| 30 · 40 | 8 | +0.015<br>0 |

■ We are ready to accept requests or orders for special parts.