

- Mount width: 65
- In addition to long nose (standard is 70 mm extension from the normal type), extra 150 mm extension (SC) is available.
- Automatic alignment mechanism of the V-shaped guide
- Working Force (300,000 strokes) 14.7kN
- Available angle is 0° to 25° at increments of 5°

■ SULNC Specifications

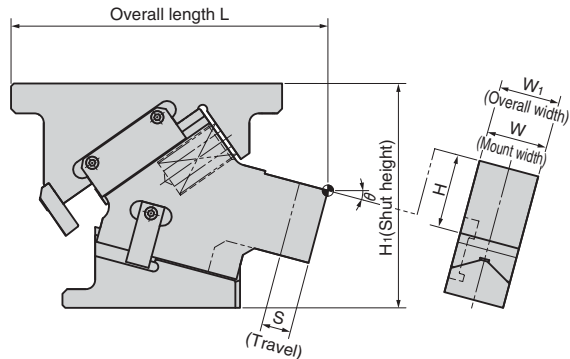

Mount Surface		Working Angle θ	Travel S	Working Force kN(tonf) (300,000 strokes)	Unit Size			Spring Force N(kgf)	
W	H				W ₁	H ₁	L	Initial Load	Final Load
65	80	00	30.2	14.7 (1.5)	65	240	335.00	126.9(12.9)	2115.0 (215.7)
		05	31.9				338.62	211.5(21.6)	
		10	35.0				341.65	211.5(21.6)	
		15	31.4				339.01	550.0(56.1)	
		20	32.3				335.66	634.5(64.7)	
		25	35.0				331.55	634.5(64.7)	

■ Structure and Assembly/Disassembly of SULNC.

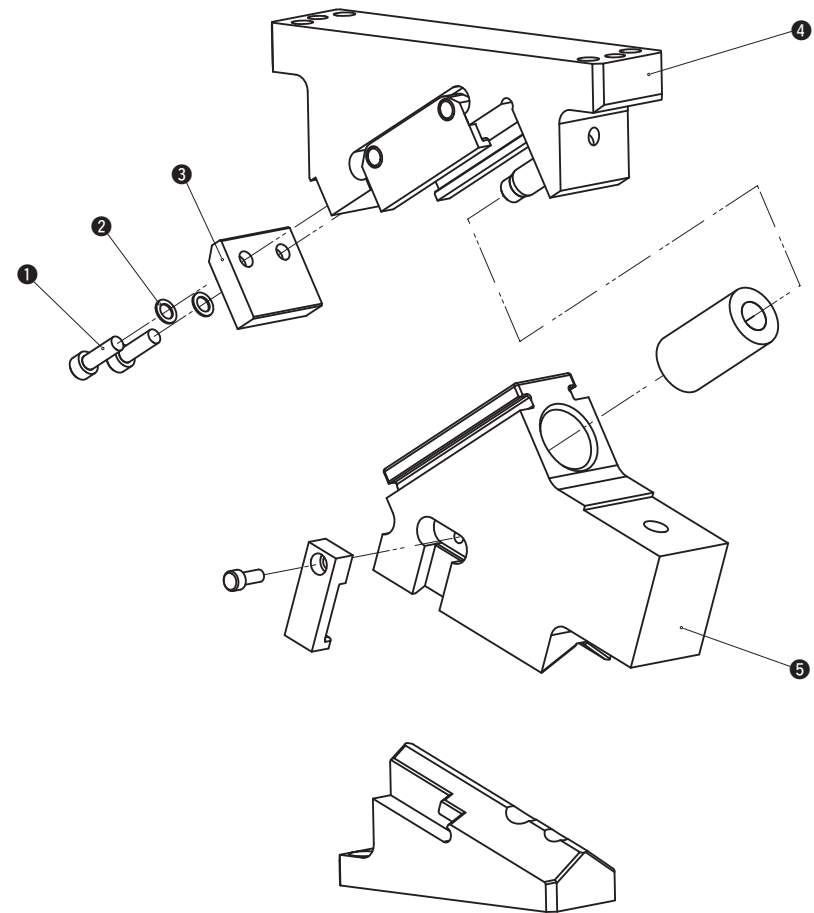

● Disassembly method of SULNC

- 1) Remove hexagon socket head bolt (1) and washer (2), and remove stopper plate (3).
- 2) Pull and remove cam slider (5) from cam holder (4) to the rear.

● Assembly method of SULNC

- 1) Assemble components in the reverse order of disassembly.
 - Make sure that there is no foreign matter on the sliding area and assemble components.
 - The clearance between the cam slider and the cam holder is controlled. Match the stamped serial number on the holder and slider before assembly.
 - When cam is disassembled and then reassembled, please do not forget to assemble all bolts provided.

Durability test for 300,000 strokes: No problem

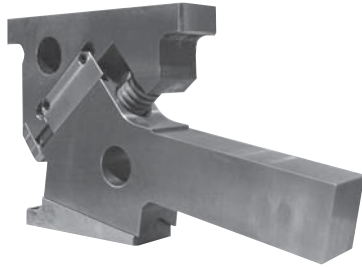

A long nose type cam slider may cause run-out of the nose end due to wear. If run-out occurs, the product may have burrs. In a worst case, the punch may not fit with the button die, resulting in damage to the die. These may be attributable to wear resistance, accuracy of components and degree of total accuracy. Sankyo's long nose type cam has achieved the durability test of 300,000 strokes to ensure higher quality product and customer satisfaction.

■ Durability test and result

● Contents of the test

1. Load of 14.7 kN (1.5 tonf) was applied to the mount of the long nose type cam and the durability test of 300,000 strokes was performed. (Photo 1)
2. After the durability test in 1, a panel piercing test was performed to check run-out at the end. (Photo 2)

● Testing conditions

- a. Cam specification used in the test
SULNC65-10-SC150
(Max 150 of nose length and 10° of working angle was applied.)

b. Testing conditions

(1) Durability test

Load	14.7kN(1.5tonf)
Number of strokes	300,000 strokes
Press speed	35spm
Entry	5mm
Grease	Albania EP grease

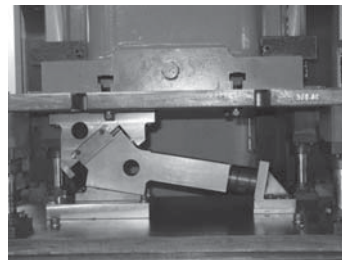

Photo 1(Lower Dead Point)

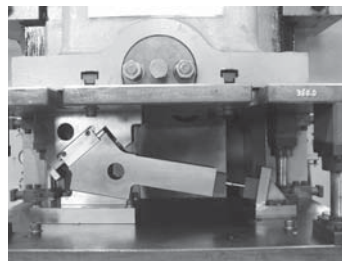

Photo 2(Lower Dead Point)

(2) Panel piercing test

Press speed	35spm
Working Force	7.5kN
Material	SPCC
Thickness	0.8mm

Number of shots	30
Punch diameter	φ10.00
Button die diameter	φ10.08

● Test result

After the durability test of 300,000 strokes, performance sliding is good. It was found that there was no problem for run-out of the long nose in the panel stamping test.

1. Durability test result

- There was no scoring in the durability test (300,000 strokes) and the sliding surface was good. (Refer to the photo in the right.)
- Total wear (Change of nose end height) was approximately 12 μm.

2. Panel stamping test result

- The worn out amount (lateral) checked by hand at the lower dead point is:
Before durability test - 10 μm.
After durability test ----- 2 μm.
- The panel stamping test was performed 30 times. No burr was observed.

(Status of sliding surface after test)

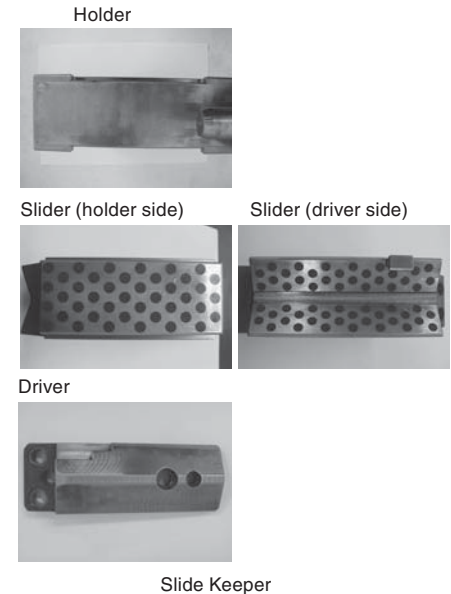

(Status of pierce hole surface)

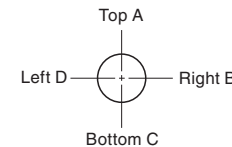

Status of pierce hole at 30th shot

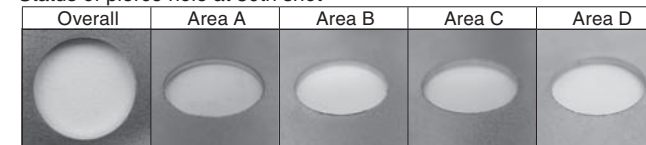

- There was no burr.
- Minor flash was felt with hand. (Areas A and B)

SULNC65-00

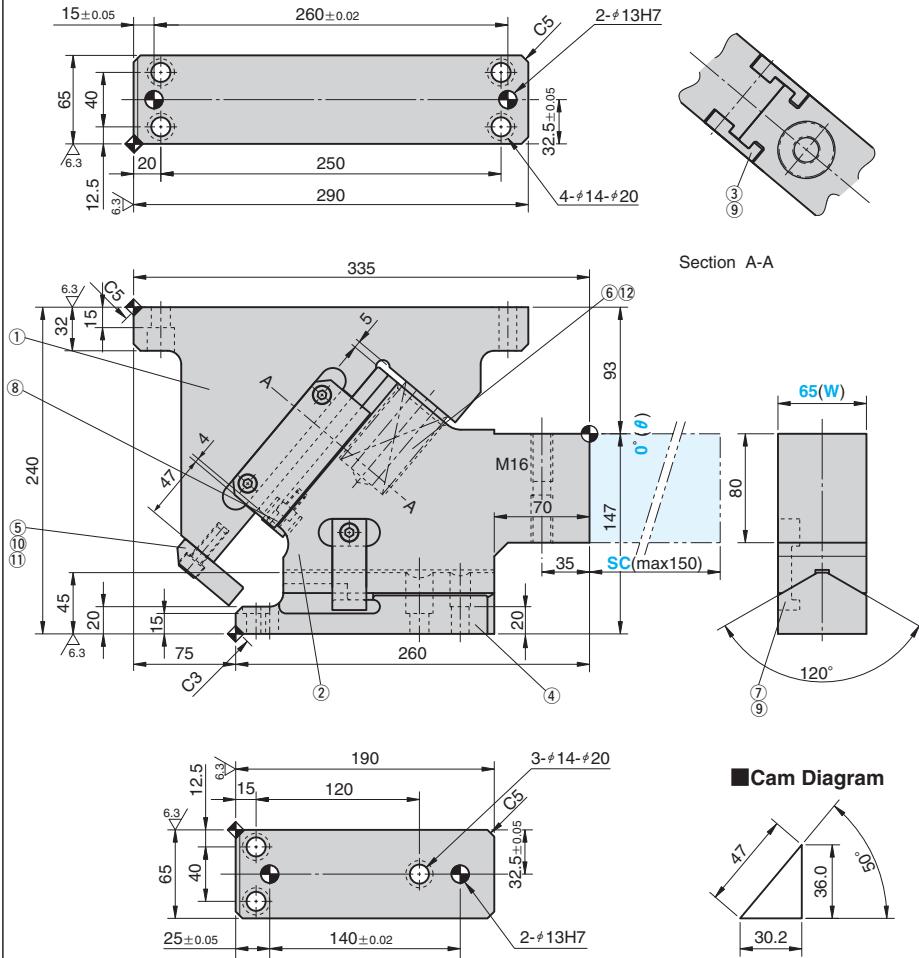

■SC Option

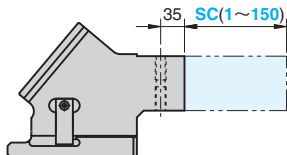

Travel S	Working Force kN(tonf) (300,000 strokes)	Spring Force N(kgf)		Total Weight kg	Catalog No.	(W)	(θ)
		Initial Load	Final Load				
30.2	14.7 (1.5)	126.9 (12.9)	2115.0 (215.7)	33.7	SULNC	65	00



Order

Catalog No. **SULNC** (W) **65** - (θ) **00**



Option

Option Code	Specification
SC	The mount surface is extended in the range from 1 to 150 mm (in the increments of 1 mm).
N12	Dowel Pin holes of cam holder and cam driver are changed to #12



Order

SULNC65-00-SC120-N12



Refer to page 551 for detailed specifications of tapped holes and dowel pin holes (prepared hole, finished hole) for retainer.

■Space for removing

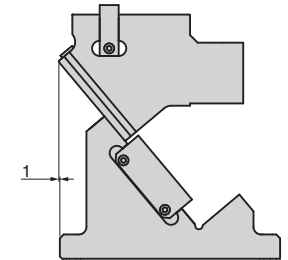

■Table of Components

No.	Description	Qty	Material and Remark
①	Cam Holder	1	FC250
②	Cam Slider	1	FC250 with Graphite
③	Slide Keeper	2	S45C with Graphite
④	Cam Driver	1	SF700
⑤	Stopper Plate	1	SS400(1020)
⑥	Coil Spring	1	TL40-125
⑦	Positive Return Follower	1	S45C(1045)
⑧	Stopper	1	Urethane
⑨	Hexagon Socket Head Bolt	5	SCM435 M8×20
⑩	Hexagon Socket Head Bolt	2	SCM435 M10×30
⑪	Spring Washer	2	M10
⑫	Spring Guide Pin	1	SPRG19-60

■Spring Diagram

(Stripping Force at punch retraction of 5mm)

- Spring Used TL40-125(1 piece)
- Spring Constant 42.3N/mm(4.31kgf/mm)

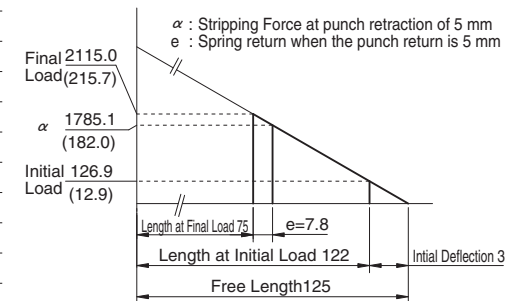

SULNC65-05

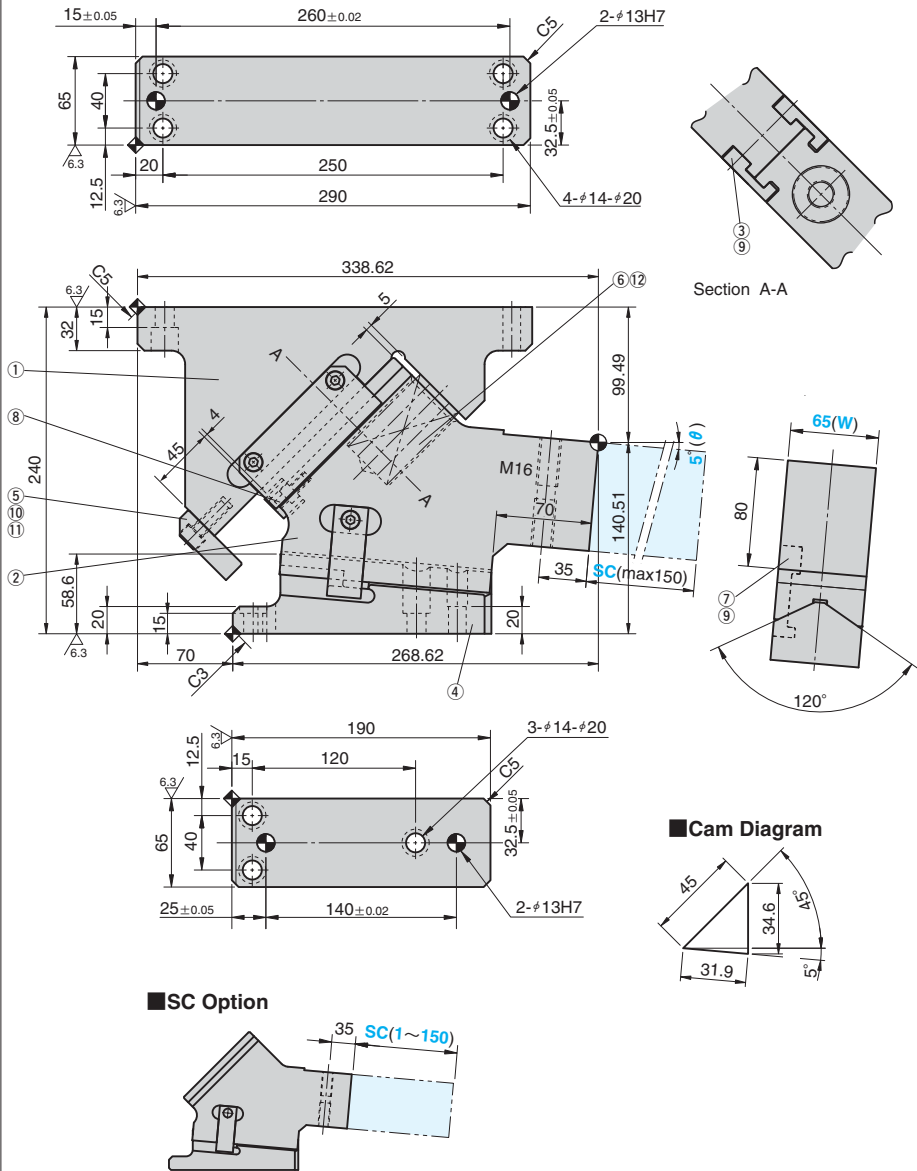

Travel S	Working Force kN(tonf) (300,000 strokes)	Spring Force N(kgf)		Total Weight kg	Catalog No.	(W)	(θ)
		Initial Load	Final Load				
31.9	14.7 (1.5)	211.5 (21.6)	2115.0 (215.7)	33.2	SULNC	65	05



Order

Catalog No. **SULNC** (W) **65** - (θ) **05**



Option

Option Code	Specification
SC	The mount surface is extended in the range from 1 to 150 mm (in the increments of 1 mm).
N12	Dowel Pin holes of cam holder and cam driver are changed to φ12



Order

SULNC65-05-SC120-N12



Refer to page 551 for detailed specifications of tapped holes and dowel pin holes (prepared hole, finished hole) for retainer.

Space for removing

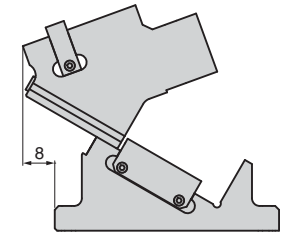

Table of Components

No.	Description	Qty	Material and Remark
①	Cam Holder	1	FC250
②	Cam Slider	1	FC250 with Graphite
③	Slide Keeper	2	S45C with Graphite
④	Cam Driver	1	SF700
⑤	Stopper Plate	1	SS400(1020)
⑥	Coil Spring	1	TL40-125
⑦	Positive Return Follower	1	S45C(1045)
⑧	Stopper	1	Urethane
⑨	Hexagon Socket Head Bolt	5	SCM435 M8×20
⑩	Hexagon Socket Head Bolt	2	SCM435 M10×30
⑪	Spring Washer	2	M10
⑫	Spring Guide Pin	1	SPRG19-60

Spring Diagram

(Stripping Force at punch retraction of 5mm)

- Spring Used TL40-125(1 piece)
- Spring Constant 42.3N/mm(4.31kgf/mm)

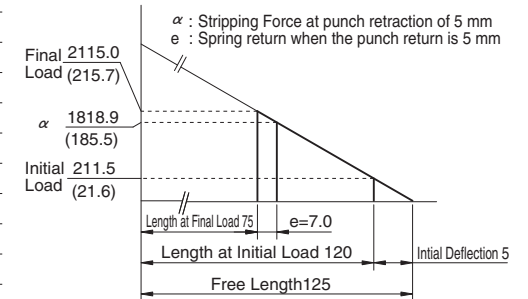

SC Option

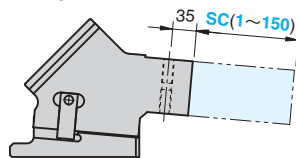

SULNC65-10

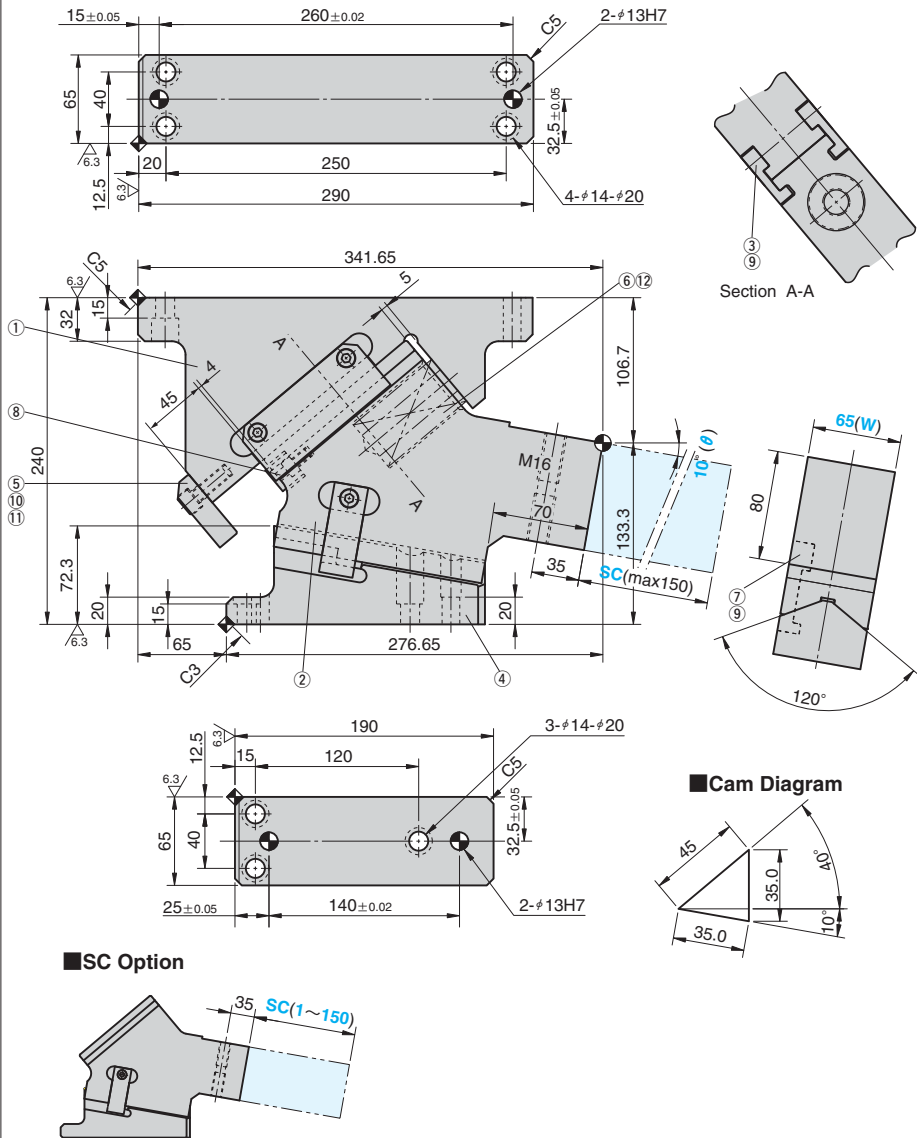

Travel S	Working Force kN(tonf) (300,000 strokes)	Spring Force N(kgf)		Total Weight kg	Catalog No.	(W)	(θ)
		Initial Load	Final Load				
35.0	14.7 (1.5)	211.5 (21.6)	2115.0 (215.7)	32.7	SULNC	65	10



Order

Catalog No. **SULNC** (W) **65** - (θ) **10**



Option

Option Code	Specification
SC	The mount surface is extended in the range from 1 to 150 mm (in the increments of 1 mm).
N12	Dowel Pin holes of cam holder and cam driver are changed to #12



Order

SULNC65-10-SC120-N12



Refer to page 551 for detailed specifications of tapped holes and dowel pin holes (prepared hole, finished hole) for retainer.

Space for removing

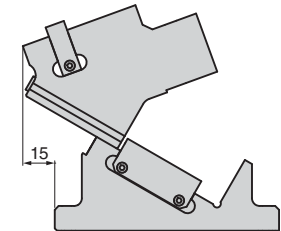

Table of Components

No.	Description	Qty	Material and Remark
①	Cam Holder	1	FC250
②	Cam Slider	1	FC250 with Graphite
③	Slide Keeper	2	S45C with Graphite
④	Cam Driver	1	SF700
⑤	Stopper Plate	1	SS400(1020)
⑥	Coil Spring	1	TL40-125
⑦	Positive Return Follower	1	S45C(1045)
⑧	Stopper	1	Urethane
⑨	Hexagon Socket Head Bolt	5	SCM435 M8×20
⑩	Hexagon Socket Head Bolt	2	SCM435 M10×30
⑪	Spring Washer	2	M10
⑫	Spring Guide Pin	1	SPRG19-60

Spring Diagram

(Stripping Force at punch retraction of 5mm)

- Spring Used TL40-125(1 piece)
- Spring Constant 42.3N/mm(4.31kgf/mm)

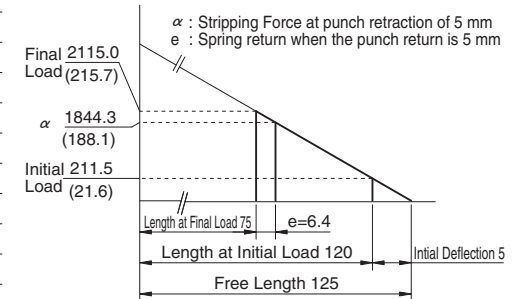

SULNC65-15

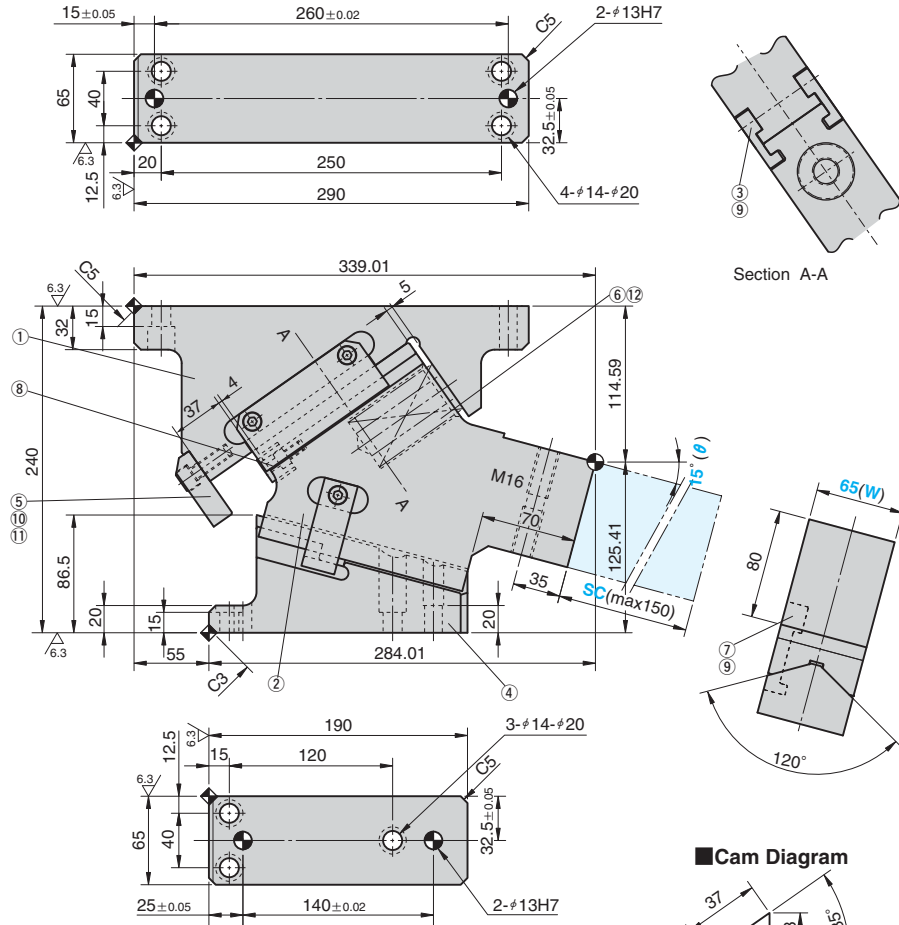

Section A-A

Cam Diagram

SC Option

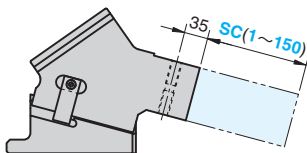

Travel S	Working Force kN(tonf) (300,000 strokes)	Spring Force N(kgf)		Total Weight kg	Catalog No.	(W)	(θ)
		Initial Load	Final Load				
31.4	14.7 (1.5)	550.0 (56.1)	2115.0 (215.7)	32.1	SULNC	65	15



Order

Catalog No. **SULNC** (W) **65** - (θ) **15**



Option

Option Code	Specification
SC	The mount surface is extended in the range from 1 to 150 mm (in the increments of 1 mm).
N12	Dowel Pin holes of cam holder and cam driver are changed to φ12



Order **SULNC65-15-SC120-N12**



Refer to page 551 for detailed specifications of tapped holes and dowel pin holes (prepared hole, finished hole) for retainer.

Space for removing

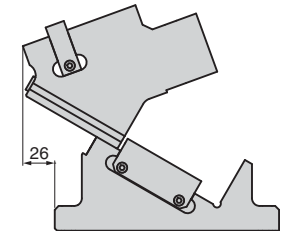

Table of Components

No.	Description	Qty	Material and Remark
①	Cam Holder	1	FC250
②	Cam Slider	1	FC250 with Graphite
③	Slide Keeper	2	S45C with Graphite
④	Cam Driver	1	SF700
⑤	Stopper Plate	1	SS400(1020)
⑥	Coil Spring	1	TL40-125
⑦	Positive Return Follower	1	S45C(1045)
⑧	Stopper	1	Urethane
⑨	Hexagon Socket Head Bolt	5	SCM435 M8×20
⑩	Hexagon Socket Head Bolt	2	SCM435 M10×30
⑪	Spring Washer	2	M10
⑫	Spring Guide Pin	1	SPRG19-60

Spring Diagram

(Stripping Force at punch retraction of 5mm)

- Spring Used TL40-125(1 piece)
- Spring Constant 42.3N/mm(4.31kgf/mm)

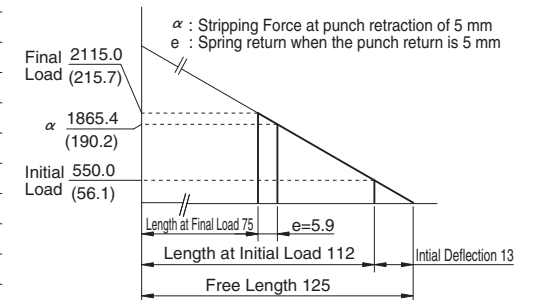

SULNC65-25

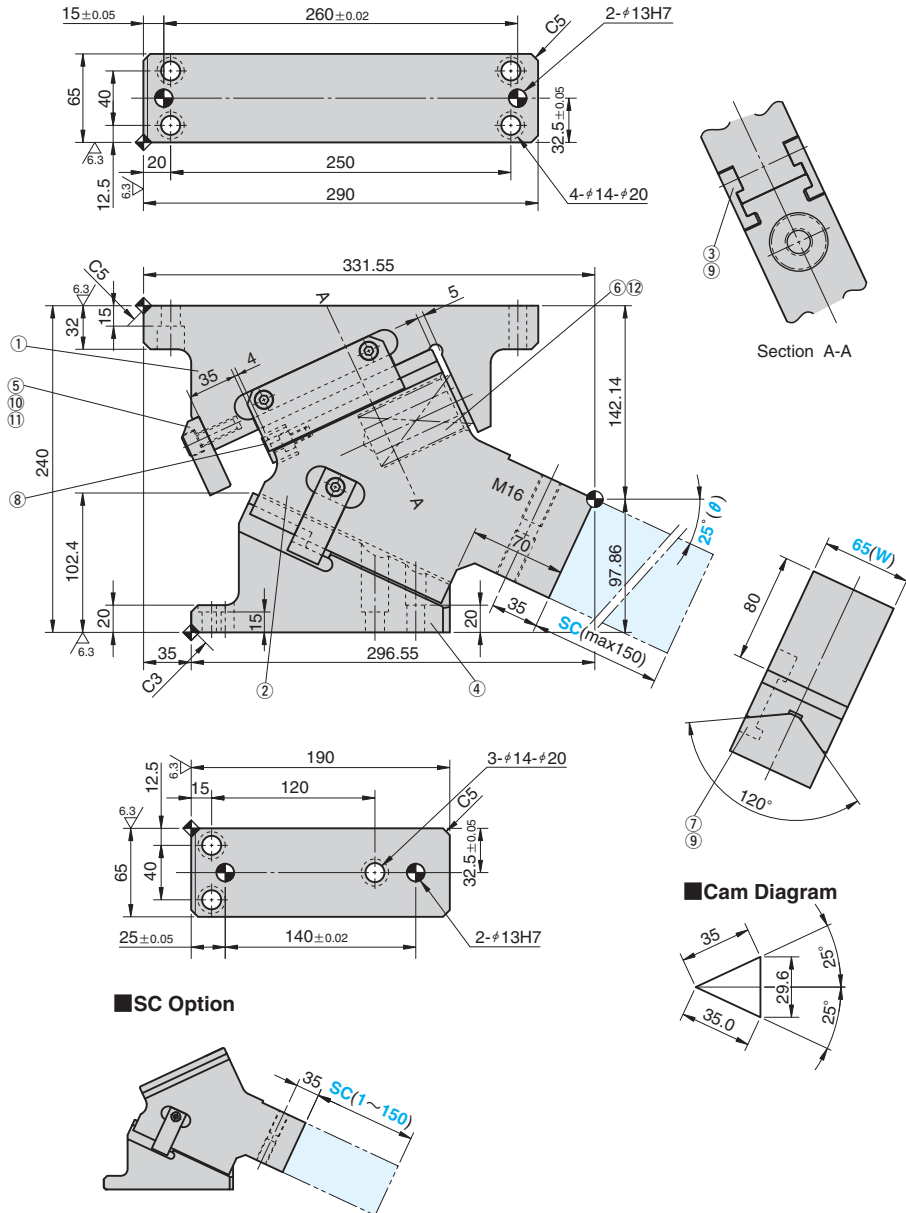

Travel S	Working Force kN(tonf) (300,000 strokes)	Spring Force N(kgf)		Total Weight kg	Catalog No.	(W)	(θ)
		Initial Load	Final Load				
35.0	14.7 (1.5)	634.5 (64.7)	2115.0 (215.7)	31.8	SULNC	65	25



Order

Catalog No. **SULNC** (W) **65** - (θ) **25**



Option

Option Code	Specification
SC	The mount surface is extended in the range from 1 to 150 mm (in the increments of 1 mm).
N12	Dowel Pin holes of cam holder and cam driver are changed to φ12



Order **SULNC65-25-SC120-N12**



Refer to page 551 for detailed specifications of tapped holes and dowel pin holes (prepared hole, finished hole) for retainer.

Space for removing

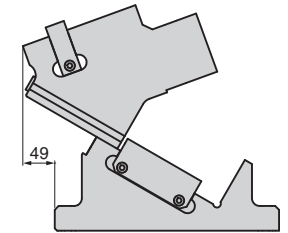

Table of Components

No.	Description	Qty	Material and Remark
①	Cam Holder	1	FC250
②	Cam Slider	1	FC250 with Graphite
③	Slide Keeper	2	S45C with Graphite
④	Cam Driver	1	SF700
⑤	Stopper Plate	1	SS400(1020)
⑥	Coil Spring	1	TL40-125
⑦	Positive Return Follower	1	S45C(1045)
⑧	Stopper	1	Urethane
⑨	Hexagon Socket Head Bolt	5	SCM435 M8×20
⑩	Hexagon Socket Head Bolt	2	SCM435 M10×30
⑪	Spring Washer	2	M10
⑫	Spring Guide Pin	1	SPRG19-60

Spring Diagram

(Stripping Force at punch retraction of 5mm)

- Spring Used TL40-125(1 piece)
- Spring Constant 42.3N/mm(4.31kgf/mm)

