

General Description of Rubber Spring

FOR HIGH DEFLECTION

Great improvement of durability

SRX is the product with a special blending method of various rubbers. It is resistant to large deflection (35%) and high load. Permanent set is limited. It is very cost effective compared to coil springs or urethane springs.



■ Features

- (1) Durability: Durability for 100 strokes (at deflection of 35%)
These rubber springs have the ability to resist until oil, chemical, heat, dust, corrosion.
- (2) Maximum deflection: 35%
- (3) Permanent set: 2% or less (at deflection of 35% and 300,000 strokes)
- (4) High buckling resistance: Buckling does not occur in parallel load. At the inclination of 3°, the spring has buckling limit of 35%.
- (5) Compact size: Since the deflection is large, the free length is approximately half of the coil spring.
- (6) Maximum load: The load is increased by approx. 10% more than the conventional parts (SR cushion).

■ Bulge of Outer Diameter

When the SRX is compressed, the outer diameter is bulged. The bulge rate is not relevant to the spring size. It is proportional to the deflection rate and the rate is almost constant of $\Delta D = 0.81 \delta$

Bulge rate of outer diameter: $\Delta D = \frac{\phi D \delta - \phi D_0}{\phi D_0} \times 100\%$

Deflection rate: $\delta = \frac{S}{L} \times 100\%$

Where

ϕD_0 : Initial outer diameter mm, L: Initial length mm

$\phi D \delta$: Maximum outer diameter, S: Deflection mm

Therefore $\phi D \delta = (1 + 0.81 \frac{S}{L}) \times \phi D_0$

The required clearance between the maximum bulge diameter and the wall is at least 5 mm.

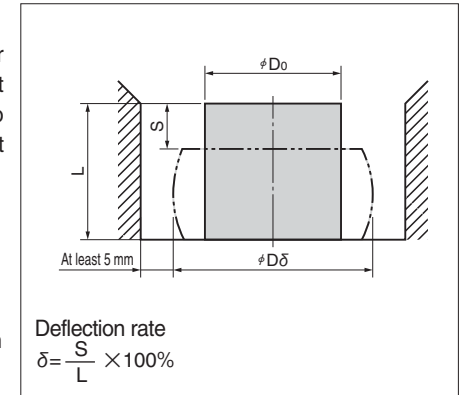

■ Application Range

(1) Heat resistance

When the SRX is repeatedly compressed, it generates heat with hysteresis effect. Temperature rise reaches a balanced value and becomes constant around 1,000 strokes. The larger the volume, deflection rate and strokes per minute (spm) are, the larger temperature rise is. When $\phi 80 \times L160$ x inner diameter $\phi 22$ is used at the deflection of 35% and at 40 spm, the balanced temperature rise is approx. 30°C. Continuous heat resistance of the SRX is 80°C.

(2) Dust resistance

The SRX is very resistant to the atmosphere with much dust or machined powder. If such dust or powder is buried in the pressurizing surface or fixed area, crack does not grow. Use the SRX as it is.

(3) Scratch resistance

If the SRX has scratches in the compression direction, it may not be broken immediately. It is better to replace it at an early stage.

(4) Durability

At the deflection of 35%, the durability is one million strokes. If the SRX is desired to be used more than 35% (up to 40%), please contact us.

(5) Oil resistance and chemical resistance

Machine Oil	◎	Acetic Acid	◎
Grinding Oil	◎	Diethyl Ether	△
Cutting Oil	◎	Trichlene	×
Hydraulic Oil	◎	Oxalic Acid	○
Gear Oil	◎	Nitric Acid (Diluted)	◎
Gasoline	△	Fuming Nitric Acid	×
Turbine Oil	○	Tar	△
Acetone	○	Toluene	×
Anitone	△	Phenol	△
Ammonia	◎	Benzene	×
Ethyl Alcohol	◎	Paint Thinner	△
Hydrochloric Acid (Hot)	×	Sulfuric Acid (Diluted)	○
Hydrochloric Acid (Cold)	△	Sulfuric Acid (Concentrated)	×
Glycerin	◎	Varnish	△

◎ No Change ○ Slightly Changed.

△ Considerably Changed. × Not Allowed.

General Description of Rubber Spring

FOR HIGH DEFLECTION

Application Example of SRX

1. Pad Cushion (Free Compression Type)

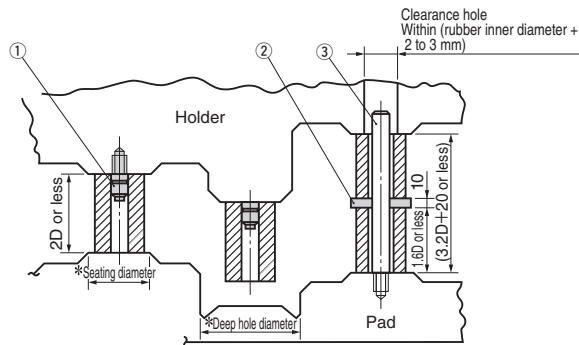

* Refer to the standard page for detailed dimensions.

- (1) Use retainer ① **SORTB** whose retaining force is improved.
- (2) It is recommended that resin spacer ② **SOIS** be used to prevent heating between rubber springs when the **SRX** is used in stages.
- (3) Use guide pin ③ (manufactured by customer) with the diameter smaller by 1 to 2 mm than the rubber inner diameter and with precision finish ($\frac{1.6}{\sqrt{V}}$).
- (4) When the **SRX** is used in stages, use the length per **SRX** which is 1.6 times the diameter.

2. Blankholder Cushion (Full-Time Compression Type)

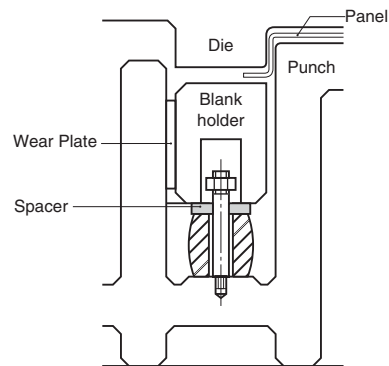

The return speed becomes slow around 3% of the free length. When it is necessary to obtain a specific height, apply a 5% preload.

3. Cam Return Cushion (Forced Initial Compression Type)

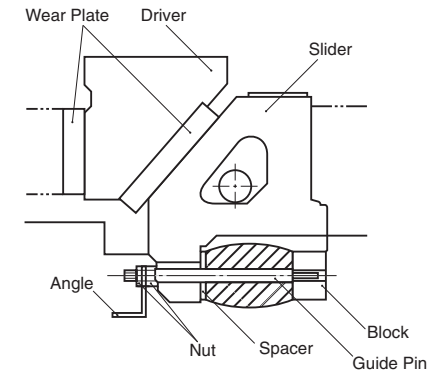

● Load - Stroke Design

Refer to the **SRX** "load - deflection diagram" for load design. Use the compression line (black line) for the load - deflection diagram. Select the appropriate keeper size that can withstand the end pressure.

(Example) **SRX** : #80×L140

Stroke : 49 mm (deflection: 35%)

A : Start pressure (20 mm before bottom dead center) = 8.5kN

B : End pressure (bottom dead center) = 15kN

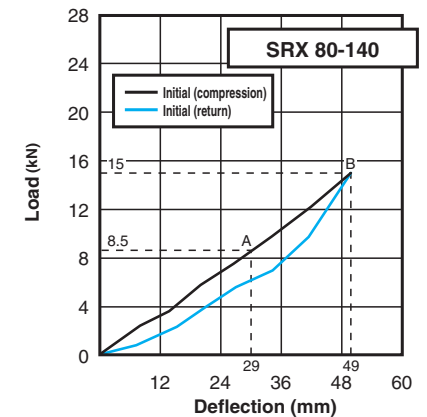

Rubber Spring

FOR HIGH DEFLECTION

ADDITION CAD FILE



SRX

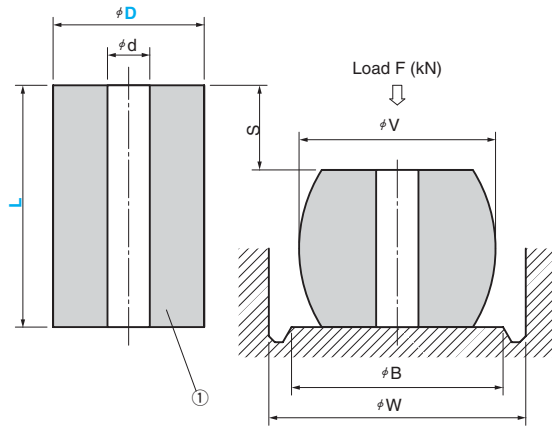

SRXT (with Retainer)

• L=40~63

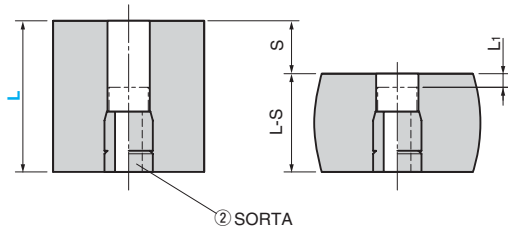

⚠ When overall length is L40~63, the retainer is SORTA.

• L=80 or more

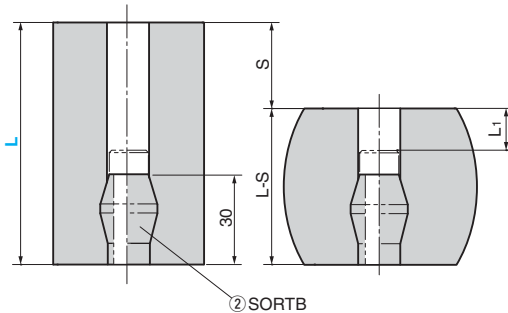

Material : ① Special blend rubber
② S25C
Hardness : Shore A69

S=L×35%			L1	B	W	d	② Retainer used for SRXT	Catalog No.	D	L
S	F(kN)	V								
10.5			—				—			30 *
14.0			8.0				SORTA14-10			40
17.5	3.2	52	4.5	60	≧62		SORTA14-20	40		50
22.1			13.0				SORTB14			63
28.0			14.0				SORTB14			80
17.5			4.5				SORTA14-20			50
22.1	5.5	65	12.9	70	≧75	14	SORTA14-20	50		63
28.0			14.0				SORTB14			80
35.0			27.0				SORTB14			100
22.1			12.9				SORTA14-20			63
28.0			14.0				SORTB14			80
35.0	10.0	81	27.0	85	≧91		SORTB14	63 (with Retainer)	63	100
43.8			43.2							125
28.0			10.0							80
35.0			23.0							100
43.8	15.0	103	39.2	110	≧114				80	125
49.0			49.0							140
56.0			62.0			22	SORTB22			160
35.0			23.0							100
43.8	24.5	129	39.2	130	≧139				100	125
49.0			49.0							140
56.0			62.0							160



Order

Catalog No.	D	—	L
SRX	50	—	80
SRXT	50	—	80

*40-30 is SRX only.

*When the deflection is 35%, the SRX can be used up to one million strokes.



Refer to page 516 for retainer (②) and the spacer for stack use of springs.



F value in above chart shows average force. Load-deflection diagram shown next page is from actual test data.

Rubber Spring

LOAD - DEFLECTION DIAGRAMS

SRX40

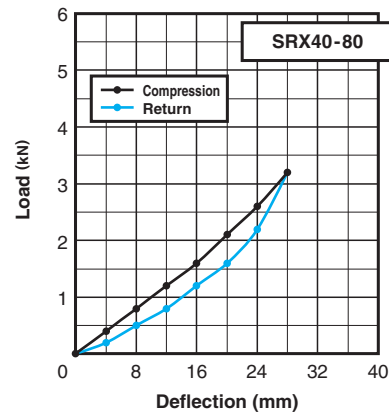
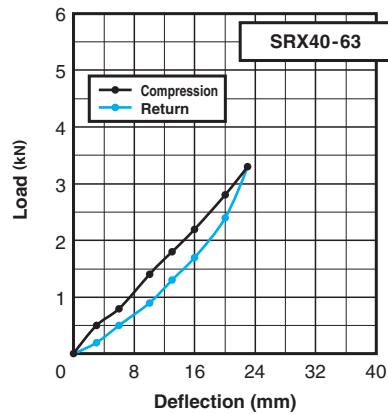
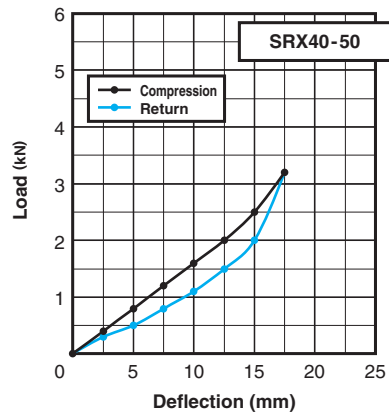
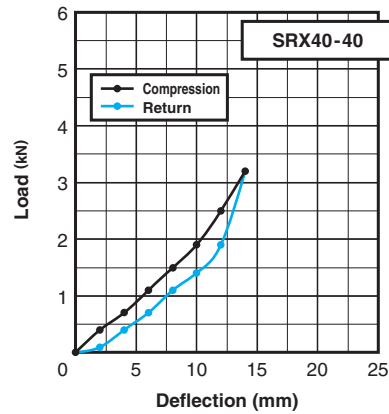
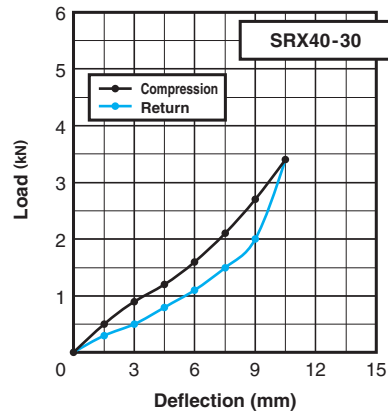

SRX50

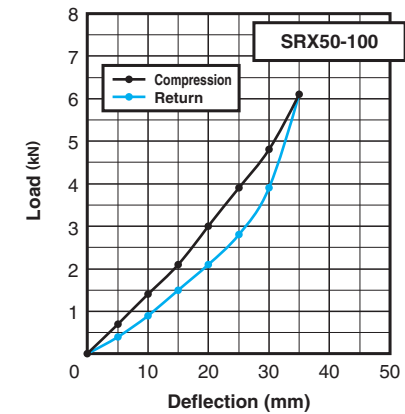
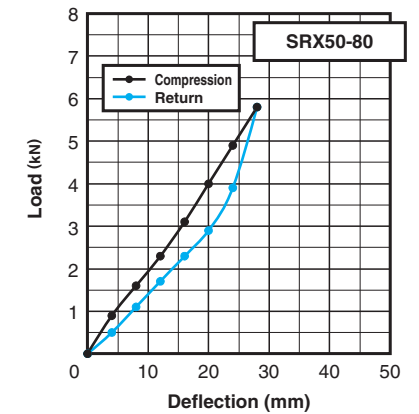
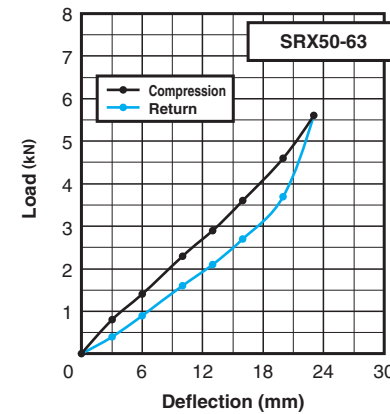
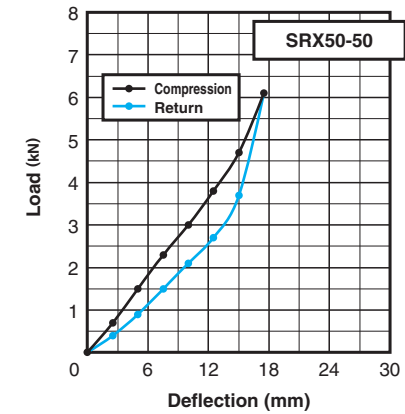

Rubber Spring

LOAD - DEFLECTION DIAGRAMS

SRX63

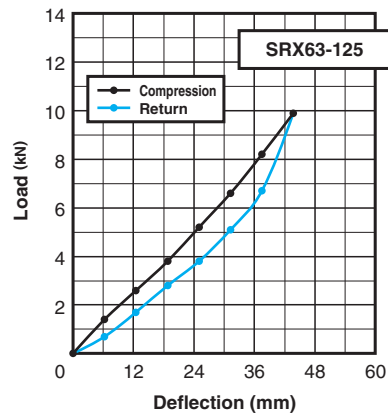
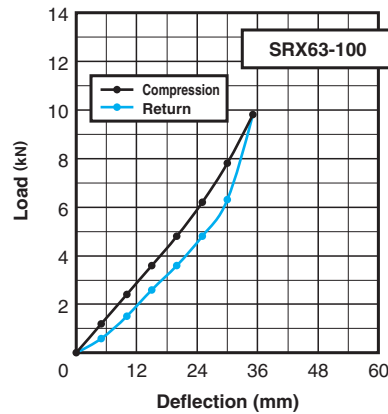
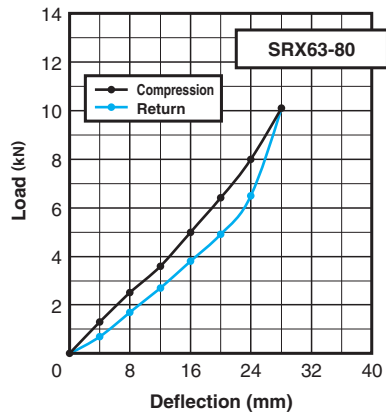
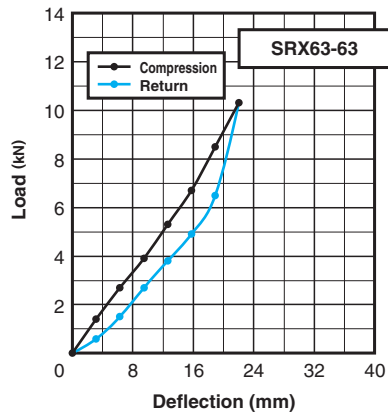

SRX80

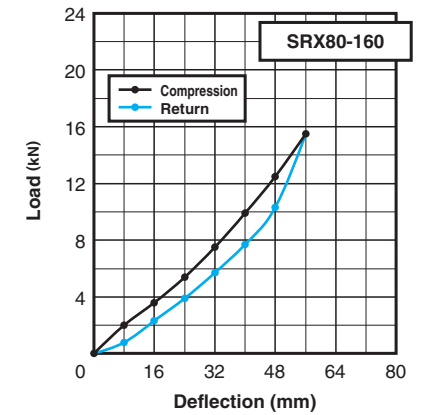
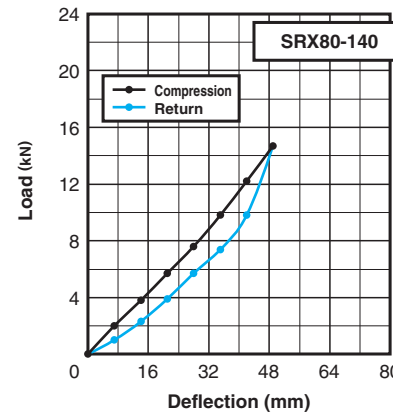
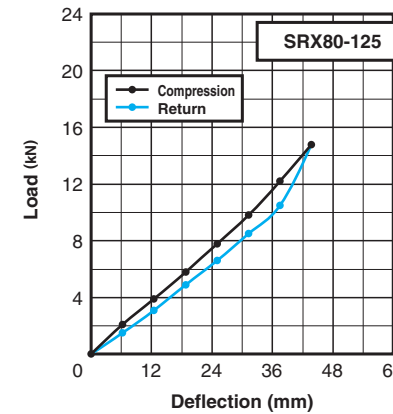
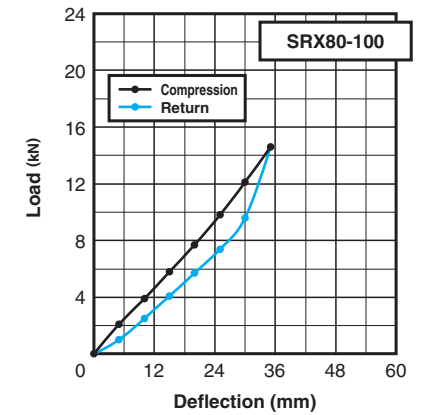
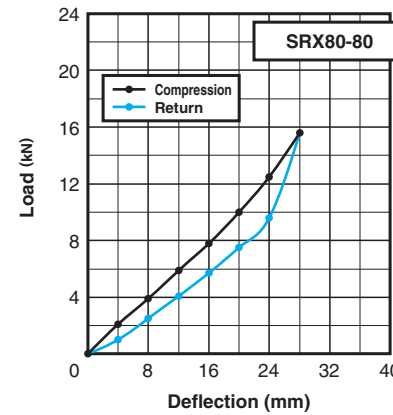

Rubber Spring

LOAD - DEFLECTION DIAGRAMS

■SRX100

