

General Description of Rubber Spring SRV

FOR HIGH LOAD

Load is increased twice compared to the previous type.

With innovation of material and manufacturing, SRV has improved performances in various characteristics; load, permanent set, durability, etc. The cost effectiveness is excellent compared to coil springs or urethane springs.

Contribution to reduction of tool costs !

- Reduction of number of pieces
- Reduction of spring setting machining hours

Great increase of load: Twice (compared to SRX)

Compared to a conventional part, load can be increased about twice with 35% maximum deflection. Some areas may be replaced with gas springs.

● Load comparison: Example of φ 63-100

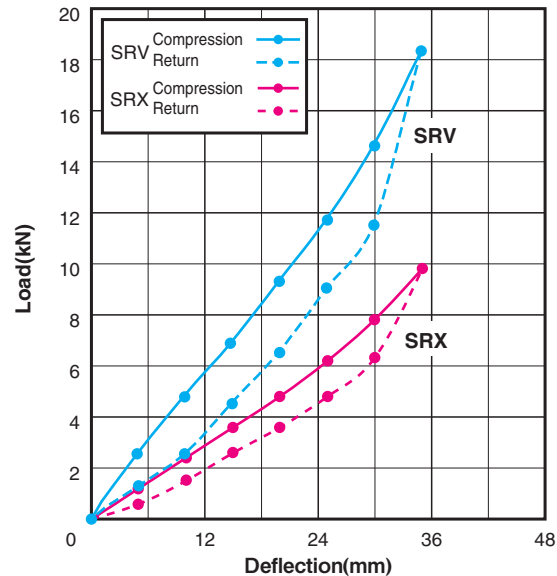

4% or less permanent set is achieved.

With 35% deflection, 4% or less permanent set is achieved at 300,000 strokes.

Durability

With 35% deflection, durability of 300,000 strokes is achieved. It is excellent in oil resistance, chemical resistance, heat resistance, dust resistance and corrosion resistance.

SRV can be used in double stack.

Double stack can be allowed when the allowable maximum deflection is 30% or less and L/D is 1.6 or less.

Bulge of Outer Diameter

When the SRV is compressed, the outer diameter is bulged. The bulge rate is not relevant to the spring size. It is proportional to the deflection rate and the rate is almost constant of $\Delta D = 0.86 \delta$.

Bulge rate of outer diameter: $\delta = \frac{S}{L} \times 100\%$

Deflection rate: $\Delta D = \frac{\phi D \delta - \phi D_0}{\phi D_0} \times 100\%$

Where

ϕD_0 : Initial outer diameter mm, L: Initial length mm

ϕD : Maximum outer diameter mm, S: Deflection mm

Therefore, $\phi D = (1 + 0.86 \frac{S}{L}) \times \phi D_0$

The required clearance between the maximum bulge diameter and the wall is at least 5 mm.

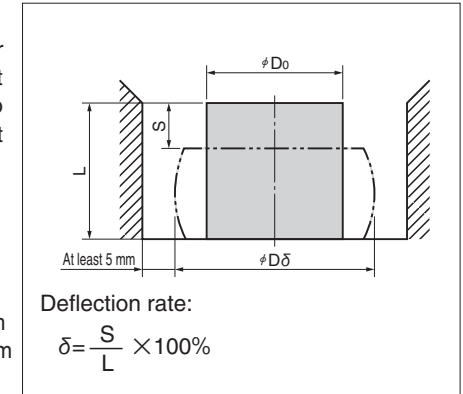

Application range

(1) Heat resistance

When the SRV is repeatedly compressed, it generates heat with hysteresis effect. Temperature rise reaches a balanced value and becomes constant around 1,000 strokes. The larger volume, deflection rate and strokes per minute (spm) are, the larger temperature.

(2) Dust resistance

The SRV is very resistant to the atmosphere with much dust or machined powder. If such dust or powder is buried in the pressurizing surface or fixed area, crack does not grow. Use the SRV as it is.

(3) Scratch resistance

If the SRV has scratches in the compression direction, it may not be broken immediately. It is better to replace it at an early stage.

(4) Durability

At the deflection of 35%, the durability is 300,000 strokes.

(5) Oil resistance and chemical resistance

Machine Oil	◎	Acetic Acid	◎
Grinding Oil	◎	Diethyl Ether	△
Cutting Oil	◎	Trichlene	×
Hydraulic Oil	◎	Oxalic Acid	○
Gear Oil	◎	Nitric Acid (Diluted)	◎
Gasoline	△	Fuming Nitric Acid	×
Turbine Oil	○	Tar	△
Acetone	○	Toluene	×
Anitone	△	Phenol	△
Ammonia	◎	Benzene	×
Ethyl Alcohol	◎	Paint Thinner	△
Hydrochloric Acid (Hot)	×	Sulfuric Acid (Diluted)	○
Hydrochloric Acid (Cold)	△	Sulfuric Acid (Concentrated)	×
Glycerin	◎	Varnish	△

◎ No Change ○ Slightly Changed.

△ Considerably Changed. × Not Allowed.

Load - Stroke Design

Refer to the SRV "load - deflection diagram" for load design. Use the compression line (blue line) for the load - deflection diagram.

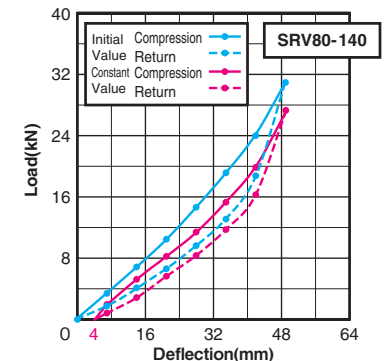

Rubber Spring

FOR HIGH LOAD

CAD
FILE

SRV

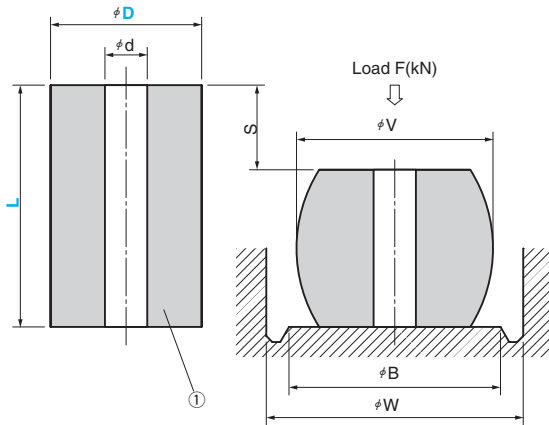

SRVT (with Retainer)

• L=50~63

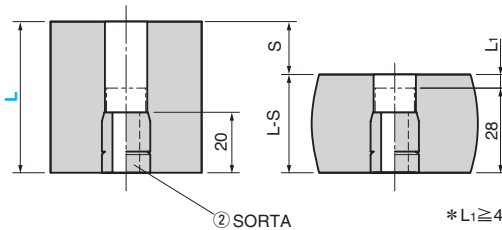

② SORTA

* $L_1 \geq 4$

⚠ When overall length is L50 and 63, the retainer is SORTA.

• L=80 or more

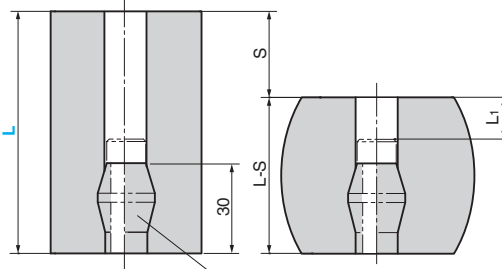

② SORTB

Material ① Special blend rubber
② S25C

S	S=L×35%			L ₁	B	W	d	Hardness JIS A	Retainer used for SRVT	Catalog No.	D	L
	Initial Value F(kN)	Stabilized Value(5~30strokes) F(kN)	V									
17.5				4.5								50
22.0	12	10	65	13	70	≧ 75	14	87	SORTA14-20		50	63
28.0				14								80
35.0				27								100
22.0	18	16	81	13	85	≧ 91	22	86	SORTA14-20		63	63
28.0				14								80
35.0				27								100
44.0				43								125
28.0				10								80
35.0				23								100
44.0	31	27	104	39	110	≧ 114					80	125
49.0				49								140
56.0				62			22	86	SORTB22			160
35.0				23								100
44.0	49	42	129	39	130	≧ 139					100	125
49.0				49								140
56.0				62								160



Order

Catalog No.

D

L

SRV
SRVT

63

—

100

80

—

140



Refer to page 516 for retainer ② and the spacer for stack use of springs.
Refer to page 513 for the deflection diagram.

For Operation

- In comparison with the conventional spring (SRX), load is doubled at the maximum compression of 35%. (Refer to the diagram in the right.)
- The permanent set is 4% or less.
At the compression rate of 35% and 300,000 strokes, the permanent set is within 4%.
- Springs can be double stacked when the allowable compression is 30% or less and L/D is 1.6 or less.

Comparison of load: Example of # 63-100

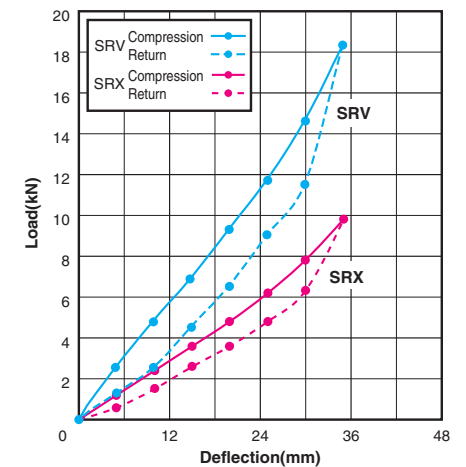

High Load Rubber Spring

LOAD-DEFLECTION DIAGRAMS

■ SRV50 Load-Deflection Diagram (The deflection in red is the permanent set.)

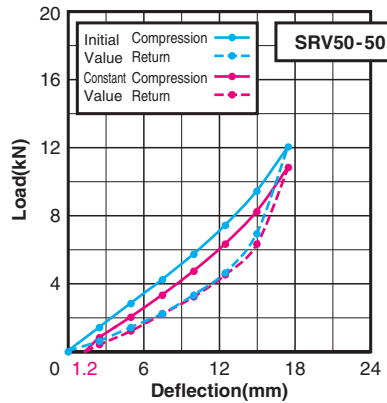

Load	Deflection (mm)									
	0	2.5	5	7.5	10	12.5	15	17.5	20	22.5
Initial Value	0.0	0.6	1.4	2.2	3.3	4.6	6.9	12.0	18.0	24.0
Constant value (5 to 300,000 strokes)	0.0	0.8	2.0	3.3	4.7	6.3	8.2	10.8	14.4	18.0

■ Load in compression (reference)

Deflection (mm)	9.5	11.5	13.5	15.5
Load (kN)	4.4	5.5	7.0	8.6

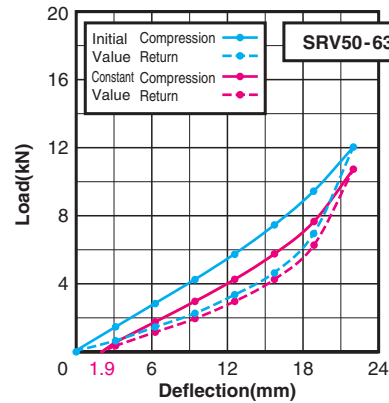

Load	Deflection (mm)									
	0	3.0	6.3	9.0	13.0	16.0	19.0	22.0	25.0	28.0
Initial Value	0.0	0.6	1.4	2.2	3.3	4.6	6.9	12.0	18.0	24.0
Constant value (5 to 300,000 strokes)	0.0	0.5	1.7	2.9	4.2	5.7	7.6	10.7	14.4	18.0

■ Load in compression (reference)

Deflection (mm)	14	16	18	20
Load (kN)	4.7	5.7	6.9	8.4

■ SRV63 Load-Deflection Chart (The deflection in red is the permanent set.)

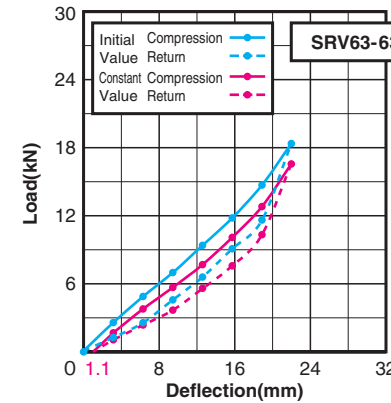

Load	Deflection (mm)									
	0	3.0	6.3	9.0	13.0	16.0	19.0	22.0	25.0	28.0
Initial Value	0.0	1.2	2.5	4.5	6.5	9.0	11.5	18.3	24.0	30.0
Constant value (5 to 300,000 strokes)	0.0	1.6	3.7	5.6	7.6	10.0	12.7	16.5	21.6	27.0

■ Load in compression (reference)

Deflection (mm)	14	16	18	20
Load (kN)	8.5	10.0	12.0	14.0

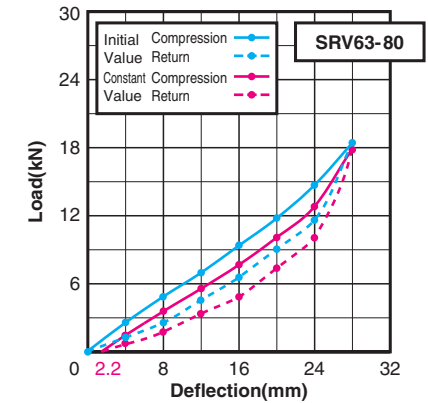

Load	Deflection (mm)									
	0	4	8	12	16	20	24	28	32	36
Initial Value	0.0	1.2	2.5	4.5	6.5	9.0	11.5	18.3	24.0	30.0
Constant value (5 to 300,000 strokes)	0.0	1.4	3.5	5.5	7.6	10.0	12.7	16.8	21.6	27.0

■ Load in compression (reference)

Deflection (mm)	20	22	24	26
Load (kN)	10.0	11.3	12.7	15.2

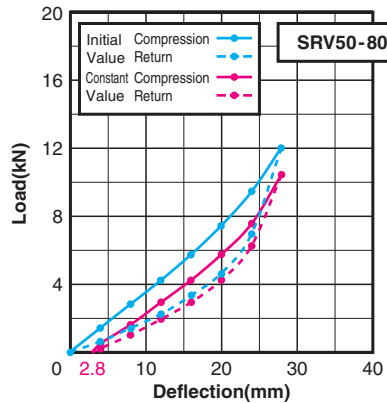

Load	Deflection (mm)									
	0	4	8	12	16	20	24	28	32	36
Initial Value	0.0	0.6	1.4	2.2	3.3	4.6	6.9	12.0	18.0	24.0
Constant value (5 to 300,000 strokes)	0.0	0.5	1.6	2.9	4.2	5.7	7.5	10.4	14.4	18.0

■ Load in compression (reference)

Deflection (mm)	20	22	24	26
Load (kN)	5.7	6.4	7.5	8.6

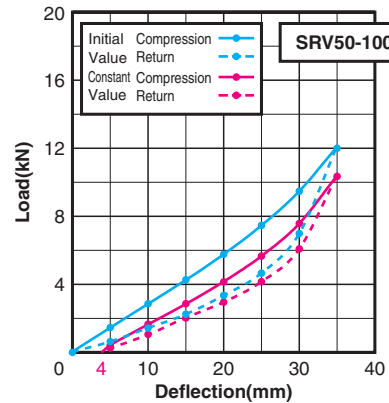

Load	Deflection (mm)									
	0	5	10	15	20	25	30	35	40	45
Initial Value	0.0	0.6	1.4	2.2	3.3	4.6	6.9	12.0	18.0	24.0
Constant value (5 to 300,000 strokes)	0.0	0.4	1.6	2.8	4.1	5.6	7.5	10.3	14.4	18.0

■ Load in compression (reference)

Deflection (mm)	27	29	31	33
Load (kN)	6.3	7.0	8.0	9.0

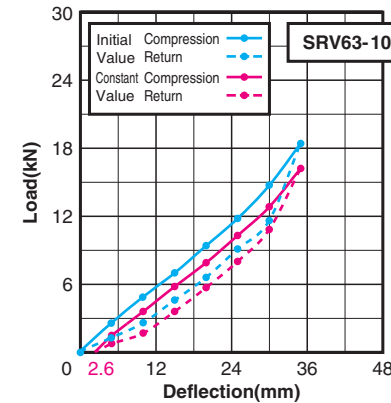

Load	Deflection (mm)									
	0	5	10	15	20	25	30	35	40	45
Initial Value	0.0	1.2	2.5	4.5	6.5	9.0	11.5	18.3	24.0	30.0
Constant value (5 to 300,000 strokes)	0.0	1.4	3.5	5.7	7.8	10.2	12.7	16.1	21.6	27.0

■ Load in compression (reference)

Deflection (mm)	27	29	31	33
Load (kN)	11.1	12.2	13.4	14.7

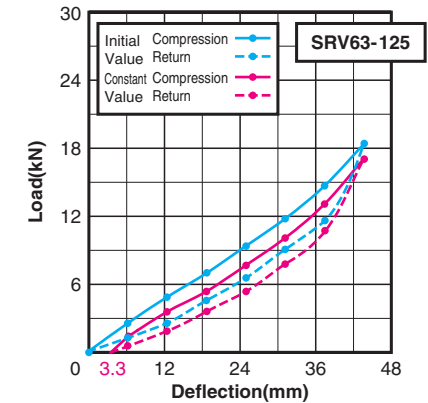

Load	Deflection (mm)									
	0	6.0	12.5	19.0	25.0	31.0	38.0	44.0	50.0	56.0
Initial Value	0.0	1.2	2.5	4.5	6.5	9.0	11.5	18.3	24.0	30.0
Constant value (5 to 300,000 strokes)	0.0	1.3	3.5	5.3	7.6	10.0	13.0	17.0	21.6	27.0

■ Load in compression (reference)

Deflection (mm)	36	38	40	42
Load (kN)	12.2	13.0	14.5	15.8

High Load Rubber Spring

LOAD-DEFLECTION DIAGRAMS

■ SRV80 Load-Deflection Chart(The deflection in red is the permanent set.)

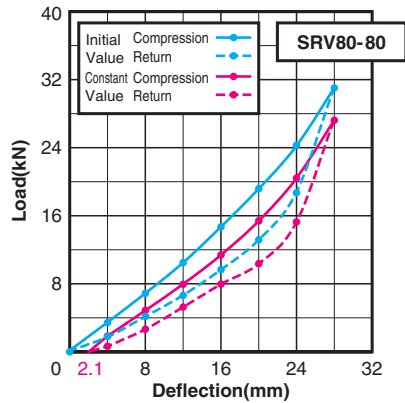

Load	Deflection (mm)								
	0	4	8	12	16	20	24	28	32
Initial Value	Compression	0.0	3.3	6.7	10.3	14.5	19.0	24.0	30.8
	Value Return	0.0	1.6	4.0	6.5	9.5	13.0	18.5	30.8
Constant value (5 to 300,000 strokes)	Compression	-	1.7	4.7	7.8	11.2	15.2	20.2	27.0
	Return	-	0.5	2.5	5.1	7.8	10.2	15.0	27.0

■ Load in compression (reference)

Deflection (mm)	20	22	24	26
Load (kN)	15.2	17.5	20.2	23.4

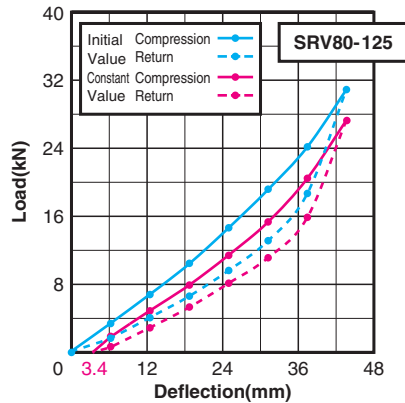

Load	Deflection (mm)									
	0	6.0	12.5	19.0	25.0	31.0	38.0	44.0		
Initial Value	Compression	0.0	3.3	6.7	10.3	14.5	19.0	24.0	30.8	
	Value Return	0.0	1.6	4.0	6.5	9.5	13.0	18.5	30.8	
Constant value (5 to 300,000 strokes)	Compression	-	1.7	4.8	7.8	11.3	15.2	20.3	27.2	
	Return	-	0.5	2.8	5.2	8.0	11.0	15.7	27.2	

■ Load in compression (reference)

Deflection (mm)	36	38	40	42
Load (kN)	19.0	20.3	22.9	25.1

■ SRV80 Load-Deflection Chart(The deflection in red is the permanent set.)

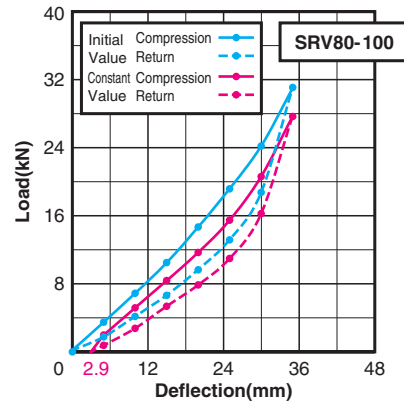

Load	Deflection (mm)								
	0	5	10	15	20	25	30	35	
Initial Value	Compression	0.0	3.3	6.7	10.3	14.5	19.0	24.0	30.8
	Value Return	0.0	1.6	4.0	6.5	9.5	13.0	18.5	30.8
Constant value (5 to 300,000 strokes)	Compression	-	1.8	5.0	8.2	11.5	15.3	20.4	27.5
	Return	-	0.6	2.6	5.2	7.7	10.8	16.0	27.5

■ Load in compression (reference)

Deflection (mm)	27	29	31	33
Load (kN)	17.2	19.3	21.7	24.4

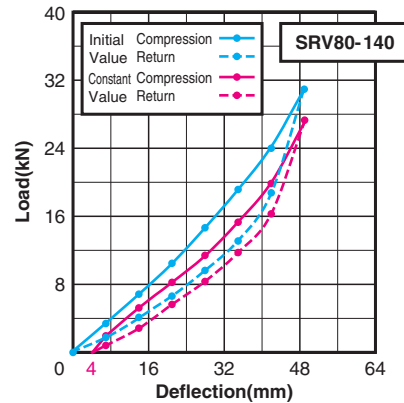

Load	Deflection (mm)								
	0	7	14	21	28	35	42	49	
Initial Value	Compression	0.0	3.3	6.7	10.3	14.5	19.0	24.0	30.8
	Value Return	0.0	1.6	4.0	6.5	9.5	13.0	18.5	30.8
Constant value (5 to 300,000 strokes)	Compression	-	1.8	5.1	8.1	11.2	15.2	19.8	26.8
	Return	-	0.7	2.7	5.5	8.2	11.6	16.1	26.8

■ Load in compression (reference)

Deflection (mm)	41	43	45	47
Load (kN)	19.2	20.8	22.6	24.6

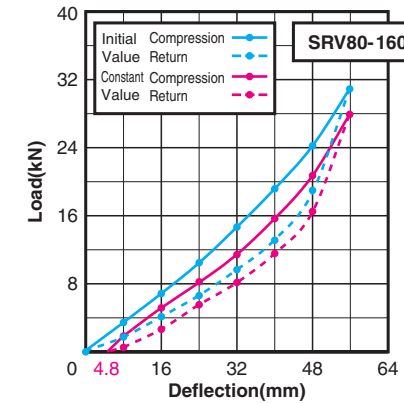

Load	Deflection (mm)									
	0	8	16	24	32	40	48	56		
Initial Value	Compression	0.0	3.3	6.7	10.3	14.5	19.0	24.0	30.8	
	Value Return	0.0	1.6	4.0	6.5	9.5	13.0	18.5	30.8	
Constant value (5 to 300,000 strokes)	Compression	-	1.7	5.0	8.0	11.3	15.5	20.5	27.8	
	Return	-	0.4	2.5	5.4	8.0	11.4	16.2	27.8	

■ Load in compression (reference)

Deflection (mm)	48	50	52	54
Load (kN)	20.5	22.2	24.0	25.8

High Load Rubber Spring

LOAD-DEFLECTION DIAGRAMS

■ SRV100 Load-Deflection Chart(The deflection in red is the permanent set.)

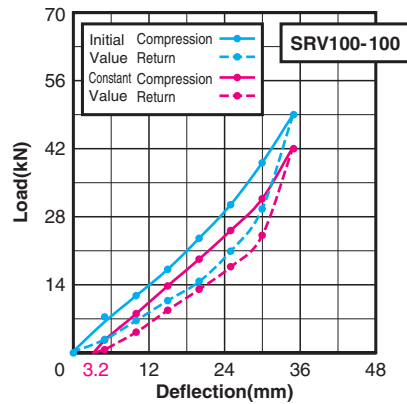

Load	Deflection (mm)								
	0	5	10	15	20	25	30	35	
Initial Value	Compression	0.0	6.1	11.5	16.9	23.3	30.2	38.8	48.9
	Return	0.0	2.5	6.4	10.5	14.4	20.6	29.2	48.9
Constant value (5 to 300,000 strokes)	Compression	-	2.4	7.8	13.5	19.0	24.9	31.4	42.2
	Return	-	0.4	4.0	8.5	12.8	17.4	23.8	42.2

■ Load in compression (reference)

Deflection (mm)	27	29	31	33
Load (kN)	27.4	30.4	33.8	37.7

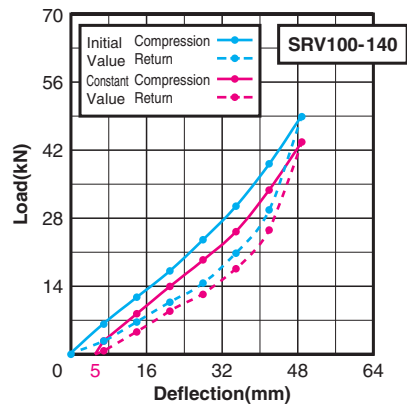

Load	Deflection (mm)								
	0	7	14	21	28	35	42	49	
Initial Value	Compression	0.0	6.1	11.5	16.9	23.3	30.2	38.8	48.9
	Return	0.0	2.5	6.4	10.5	14.4	20.6	29.2	48.9
Constant value (5 to 300,000 strokes)	Compression	-	2.5	8.1	13.7	19.1	25.0	33.5	43.5
	Return	-	0.5	4.4	8.7	12.2	17.4	25.2	43.5

■ Load in compression (reference)

Deflection (mm)	41	43	45	47
Load (kN)	32.0	34.6	37.4	40.3

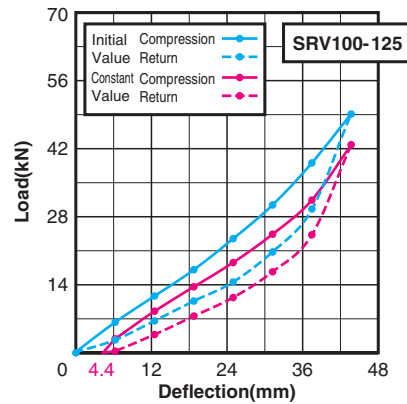

Load	Deflection (mm)								
	0	6.0	12.5	19.0	25.0	31.0	38.0	44.0	
Initial Value	Compression	0.0	6.1	11.5	16.9	23.3	30.2	38.8	48.9
	Return	0.0	2.5	6.4	10.5	14.4	20.6	29.2	48.9
Constant value (5 to 300,000 strokes)	Compression	-	2.7	8.4	13.4	18.4	24.2	31.2	42.5
	Return	-	0.2	3.6	7.4	11.2	16.5	24.0	42.5

■ Load in compression (reference)

Deflection (mm)	36	38	40	42
Load (kN)	29.5	31.2	35.5	39.0

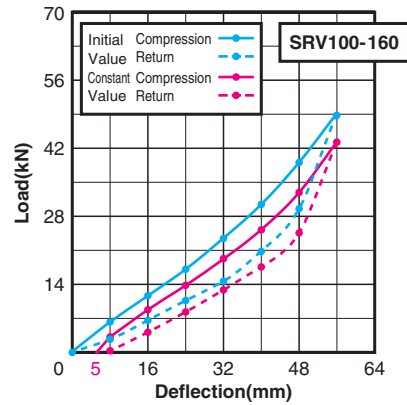

Load	Deflection (mm)								
	0	8	16	24	32	40	48	56	
Initial Value	Compression	0.0	6.1	11.5	16.9	23.3	30.2	38.8	48.9
	Return	0.0	2.5	6.4	10.5	14.4	20.6	29.2	48.9
Constant value (5 to 300,000 strokes)	Compression	-	3.0	8.6	13.6	19.0	25.0	32.6	43.0
	Return	-	0.2	4.0	8.2	12.6	17.4	24.2	43.0

■ Load in compression (reference)

Deflection (mm)	48	50	52	54
Load (kN)	32.6	35.0	37.5	40.1

Retainers and Spacers

FOR RUBBER SPRING



■ Retainer

SORTB

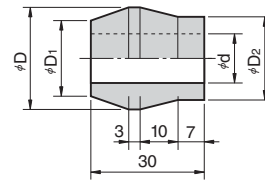

Material S25C

D	D1	D2	d	Outer Diameter	Catalog No.	Nominal
19	13	14	9	50 63	SORTB	14
27	20	22	13	80 100		22

⚠ Use SORTB when the overall length of the rubber spring is 80 or more.



Order **Catalog No.** **Nominal**
SORTB 14

SORTA

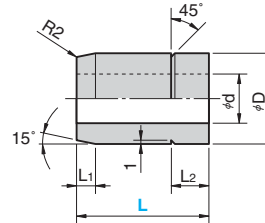

Material S25C

D	d	L1	L2	Applicable Rubber Spring		Catalog No.	Nominal	L
				Outer Diameter	Length			
16	9	3	7	40	40	SORTA	14	10
				40~63	50~63			20
				40~63	80~125			30
24	13	5	10	80~100	80~160	22	35	

⚠ When the rubber spring overall length is 40, use SORTA14-10. When the overall length is 50 and 63, use SORTA14-20.



Order **Catalog No.** **Nominal** - **L**
SORTA 14 - 20

■ Spacer

SOIS

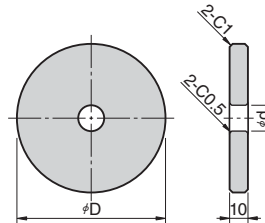

Material Neodel (#25-61N)

- Use the spacer when stacking is specified.
- Use the guide pin of S25C or equivalent with smooth surface.

Catalog No.	Nominal	D	d	Application: Rubber Spring, Urethane Spring		
				Outer Diameter	Inner Diameter	Guide Pin Diameter
SOIS	50	65	13	40 50	14	12
	63	80		63		
	80	100	21	80	20	20
	100	125		100	22	



Order **Catalog No.** **Nominal**
SOIS 63