

- Universal die mounted type.
- Sliding type with highly rigid box guide.
- 52, 65, 100, 150, 200, 250, 300 to 600 (at increments of 100 mm) are available for the mount width.
- Available angle is 0° to 20° at increments of 5° (65 to 150 width).

Slide Structure and Positive Return Structure

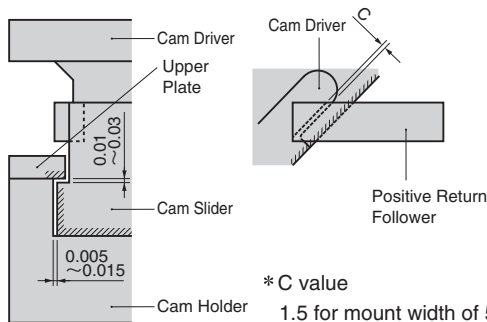

* C value
1.5 for mount width of 52 and 65
2.0 for mount width of 100 or more

* Oilless Ssystem at Hatched Area

- The clearance between the cam holder and the cam slider is 0.005 to 0.015 on one side with the complete box guide slide system.
- The clearance between the upper plate and the cam slider is 0.01 to 0.03.
- The positive return follower is not required to be a tight tolerance. It has only the positive return function.

Option of SKC/SKCA

- Key specification (-K)
Key details (1 off with M8 × 20 bolt)
SKC/SKCA 400/500/600

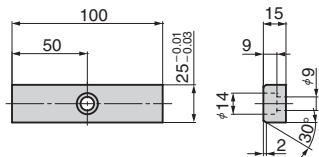

SKC/SKCA52 to 300 Structure and Assembly / Disassembly

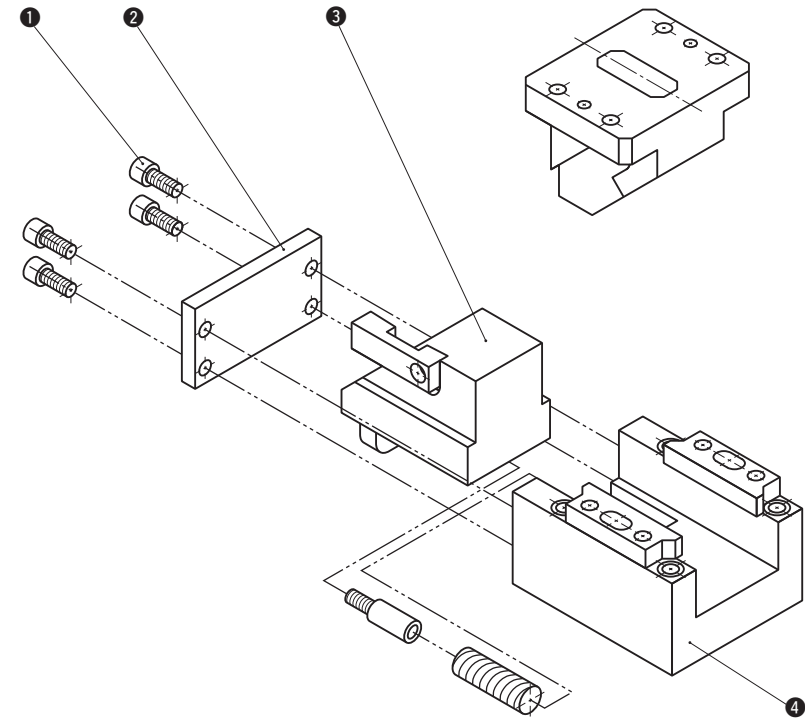

Disassembly method of SKC/SKCA

- 1) Remove hexagon socket head bolt (1) and stopper (backup) plate (2).
- 2) Pull and remove cam slider (3) to the rear.

Assembly method of SKC/SKCA

- 1) Assemble components in the reverse order of disassembly.
 - Make sure that there is no foreign matter on the sliding area and assemble components.
 - The clearance between the cam slider and cam holder (4) is controlled. Match the stamped serial number on the holder and slider before assembly.
 - When cam is disassembled and then reassembled, please do not forget to assemble all bolts provided

SKCA100-00-40 (Dowel Pin Hole Finished)
 SKC 100-00-40 (Dowel Pin Prepared Hole)

⚠ Tolerance are from dowel pin finished hole.

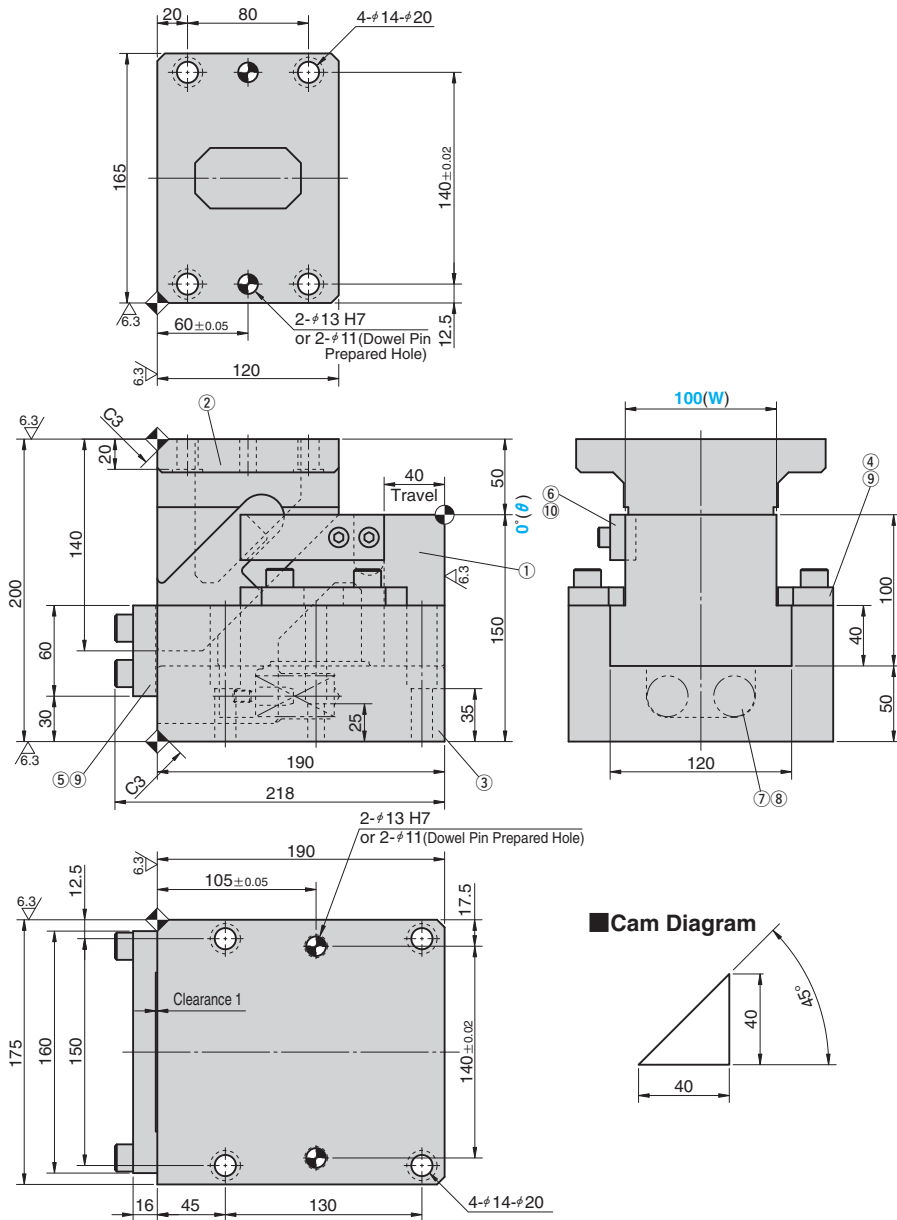

Working Force kN(tonf)		Spring Force N(kgf)		Slider Weight kg	Total Weight kg	Catalog No.	(W)	(θ)	Travel S
Standard Working Force (one million strokes)	Allowable Working Force (300,000 strokes)	Initial Load	Final Load						
29.4 (3.0)	58.8 (6.0)	188.8 (19.2)	1132.8 (115.2)	10.5	37.0	SKCA SKC	100	00	40

Order **Catalog No.** SKCA **(W)** 100 **(θ)** 00 **S** 40

Option **Option Code** N12 **Specification** The dowel pin holes for the cam holder and cam driver are changed to #12H7. (only SKCA)

Order SKCA100-00-40-N12

Refer to page 552 for detailed specifications of tapped holes and dowel pin holes (prepared hole, finish hole) for retainer.

Table of Components

No.	Description	Qty	Material and Remark
①	Cam Slider	1	FC250 with Graphite
②	Cam Driver	1	FC250 with Graphite
③	Cam Holder	1	FC250
④	Upper Plate	2	S45C Copper Powder Sintered (#220)
⑤	Stopper Plate	1	SS400(1020)
⑥	Positive Return Follower	1	S45C(1045)
⑦	Spring Guide Pin	2	φ12×40
⑧	Coil Spring	2	TF27-100
⑨	Hexagon Socket Head Bolt	8	SCM435 M12×35
⑩	Hexagon Socket Head Bolt	2	SCM435 M8×30

Spring Diagram

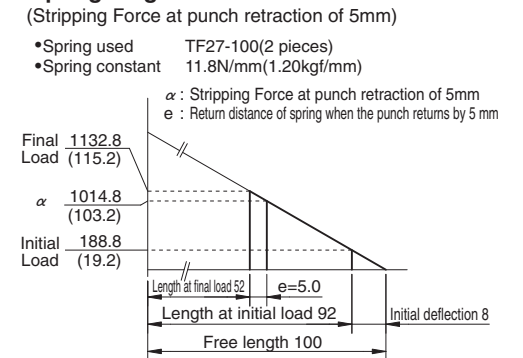

Space for removing

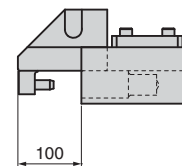

SKCA100-00-60 (Dowel Pin Hole Finished) ▲ Tolerance are from dowel pin finished hole.
 SKC 100-00-60 (Dowel Pin Prepared Hole)

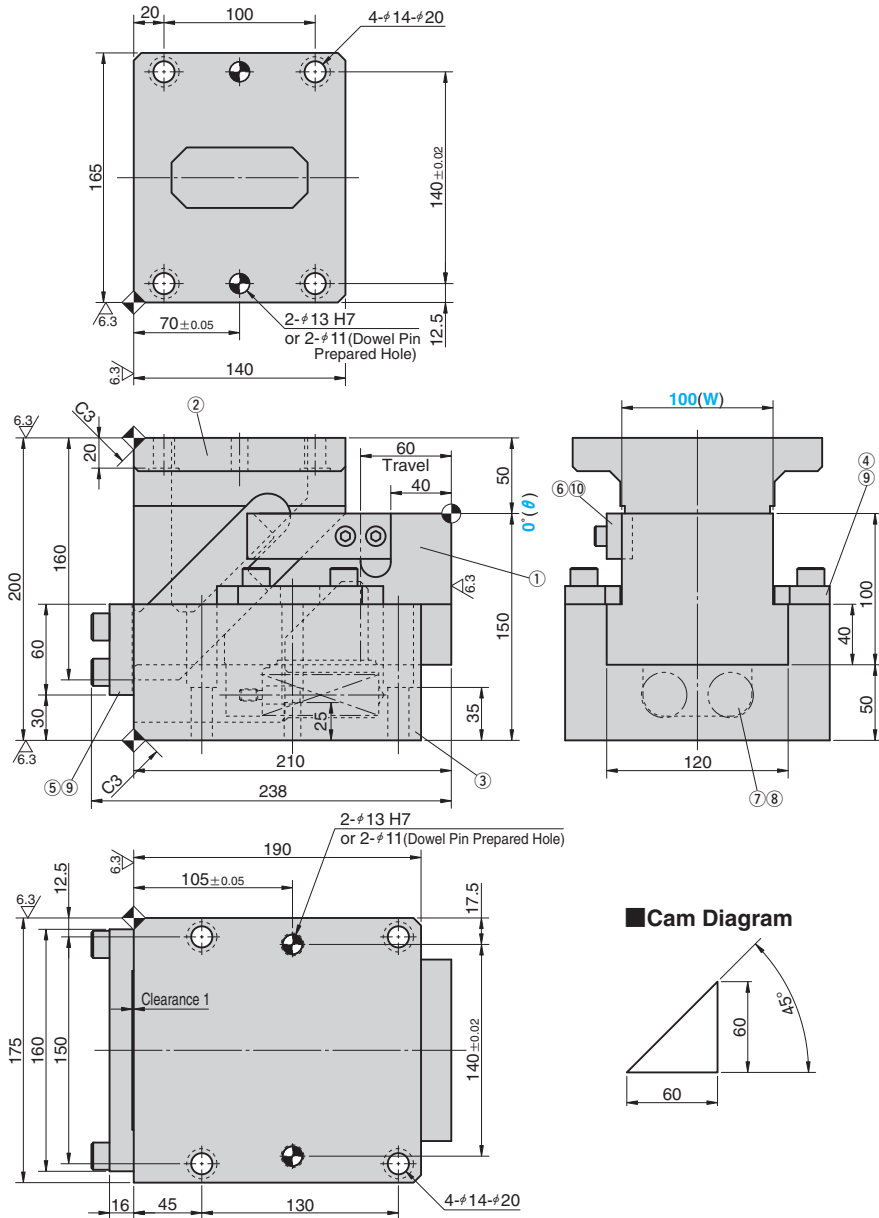

Working Force kN(tonf)		Spring Force N(kgf)		Slider Weight kg	Total Weight kg	Catalog No.	(W)	(θ)	Travel S
Standard Working Force (one million strokes)	Allowable Working Force (300,000 strokes)	Initial Load	Final Load						
29.4 (3.0)	58.8 (6.0)	202.8 (20.8)	1138.8 (116.8)	10.5	38.0	SKCA SKC	100	00	60

Order **Catalog No.** (W) - (θ) - S
 SKCA 100 - 00 - 60

Option **Option Code** **Specification**
 N12 The dowel pin holes for the cam holder and cam driver are changed to φ12H7. (only SKCA)

Order **SKCA100-00-60-N12**

Refer to page 552 for detailed specifications of tapped holes and dowel pin holes (prepared hole, finish hole) for retainer.

Table of Components

No.	Description	Qty	Material and Remark
①	Cam Slider	1	FC250 with Graphite
②	Cam Driver	1	FC250 with Graphite
③	Cam Holder	1	FC250
④	Upper Plate	2	S45C Copper Powder Sintered (#220)
⑤	Stopper Plate	1	SS400(1020)
⑥	Positive Return Follower	1	S45C(1045)
⑦	Spring Guide Pin	2	φ12×40
⑧	Coil Spring	2	TF27-150
⑨	Hexagon Socket Head Bolt	8	SCM435 M12×35
⑩	Hexagon Socket Head Bolt	2	SCM435 M8×30

Spring Diagram

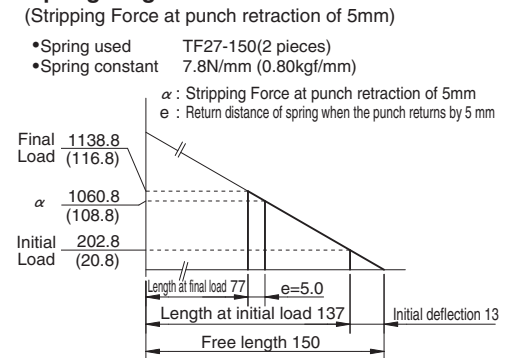

Space for removing

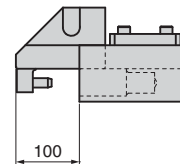

Die Mounted Cam Unit

FOR PIERCE AND FLANGE

CAD FILE

SKCA100-00-80 (Dowel Pin Hole Finished)
SKC 100-00-80 (Dowel Pin Prepared Hole)

⚠ Tolerance are from dowel pin finished hole.

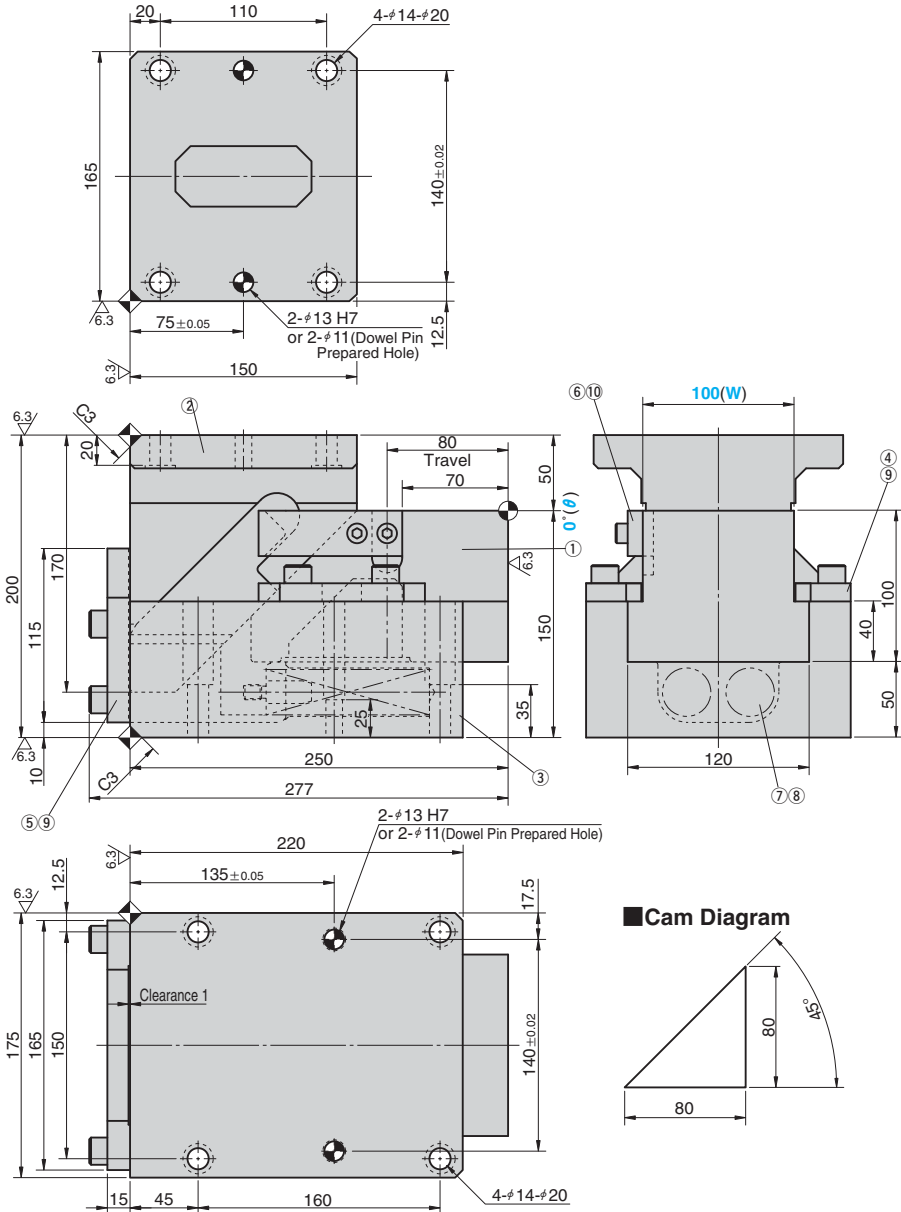

Working Force kN(tonf)		Spring Force N(kgf)		Slider Weight kg	Total Weight kg	Catalog No.	(W)	(θ)	Travel S
Standard Working Force (one million strokes)	Allowable Working Force (300,000 strokes)	Initial Load	Final Load						
29.4 (3.0)	58.8 (6.0)	170.4 (17.3)	1306.4 (132.5)	11.9	44.0	SKCA SKC	100	00	80

Order **Catalog No.** SKCA - **(W)** 100 - **(θ)** 00 - **S** 80

Option **Option Code** N12 **Specification** The dowel pin holes for the cam holder and cam driver are changed to #12H7. (only SKCA)

Order SKCA100-00-80-N12

Refer to page 552 for detailed specifications of tapped holes and dowel pin holes (prepared hole, finish hole) for retainer.

Table of Components

No.	Description	Qty	Material and Remark
①	Cam Slider	1	FC250 with Graphite
②	Cam Driver	1	FC250 with Graphite
③	Cam Holder	1	FC250
④	Upper Plate	2	S45C Copper Powder Sintered (#220)
⑤	Stopper Plate	1	SS400(1020)
⑥	Positive Return Follower	1	S45C(1045)
⑦	Spring Guide Pin	2	φ15×45
⑧	Coil Spring	2	TF30-200
⑨	Hexagon Socket Head Bolt	8	SCM435 M12×35
⑩	Hexagon Socket Head Bolt	2	SCM435 M8×30

Spring Diagram

(Stripping Force at punch retraction of 5mm)

- Spring used TF30-200(2 pieces)
- Spring constant 7.1N/mm (0.72kgf/mm)

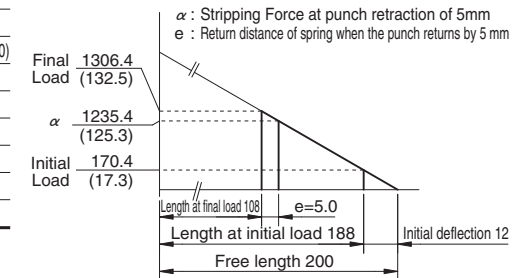

Space for removing

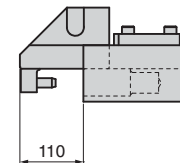

Die Mounted Cam Unit

FOR PIERCE AND FLANGE

CAD FILE

SKCA100 - 05 - 45 (Dowel Pin Hole Finished)
SKC 100 - 05 - 45 (Dowel Pin Prepared Hole)

⚠ Tolerance are from dowel pin finished hole.

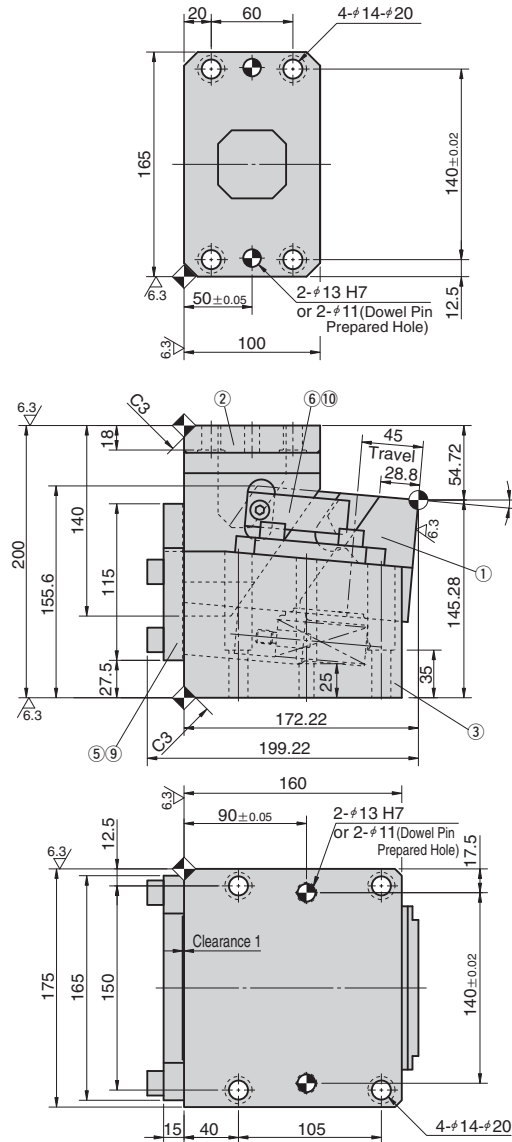

Cam Diagram

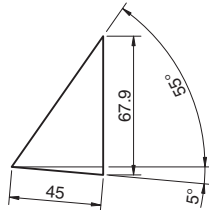

Working Force kN(tonf)		Spring Force N(kgf)		Slider Weight kg	Total Weight kg	Catalog No.	(W)	(θ)	Travel S
Standard Working Force (one million strokes)	Allowable Working Force (300,000 strokes)	Initial Load	Final Load						
39.2 (4.0)	78.4 (8.0)	263.2 (26.9)	1109.2 (113.3)	7.2	33.0	SKCA SKC	100	05	45



Order

Catalog No.	(W)	(θ)	S
SKCA	100	05	45



Option

Option Code	Specification
N12	The dowel pin holes for the cam holder and cam driver are changed to #12H7. (only SKCA)



Order

SKCA100 - 05 - 45 - N12



Refer to page 552 for detailed specifications of tapped holes and dowel pin holes (prepared hole, finish hole) for retainer.

Table of Components

No.	Description	Qty	Material and Remark
①	Cam Slider	1	FC250 with Graphite
②	Cam Driver	1	FC250 with Graphite
③	Cam Holder	1	FC250
④	Upper Plate	2	S45C Copper Powder Sintered (#220)
⑤	Stopper Plate	1	SS400(1020)
⑥	Positive Return Follower	2	S45C(1045)
⑦	Spring Guide Pin	2	φ12×40
⑧	Coil Spring	2	TF27-125
⑨	Hexagon Socket Head Bolt	8	SCM435 M12×35
⑩	Hexagon Socket Head Bolt	2	SCM435 M8×25

Spring Diagram

(Stripping Force at punch retraction of 5mm)

- Spring used TF27-125(2 pieces)
- Spring constant 9.4N/mm (0.96kgf/mm)

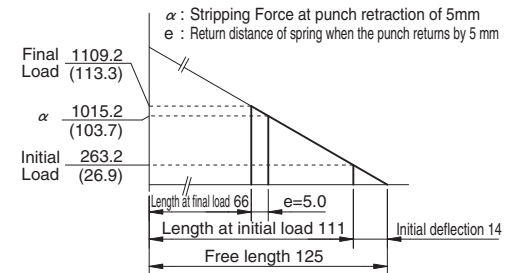

Space for removing

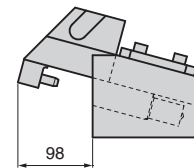

Die Mounted Cam Unit

FOR PIERCE AND FLANGE

CAD FILE

SKCA100 - 10 - 45 (Dowel Pin Hole Finished)
 SKC 100 - 10 - 45 (Dowel Pin Prepared Hole)

⚠ Tolerance are from dowel pin finished hole.

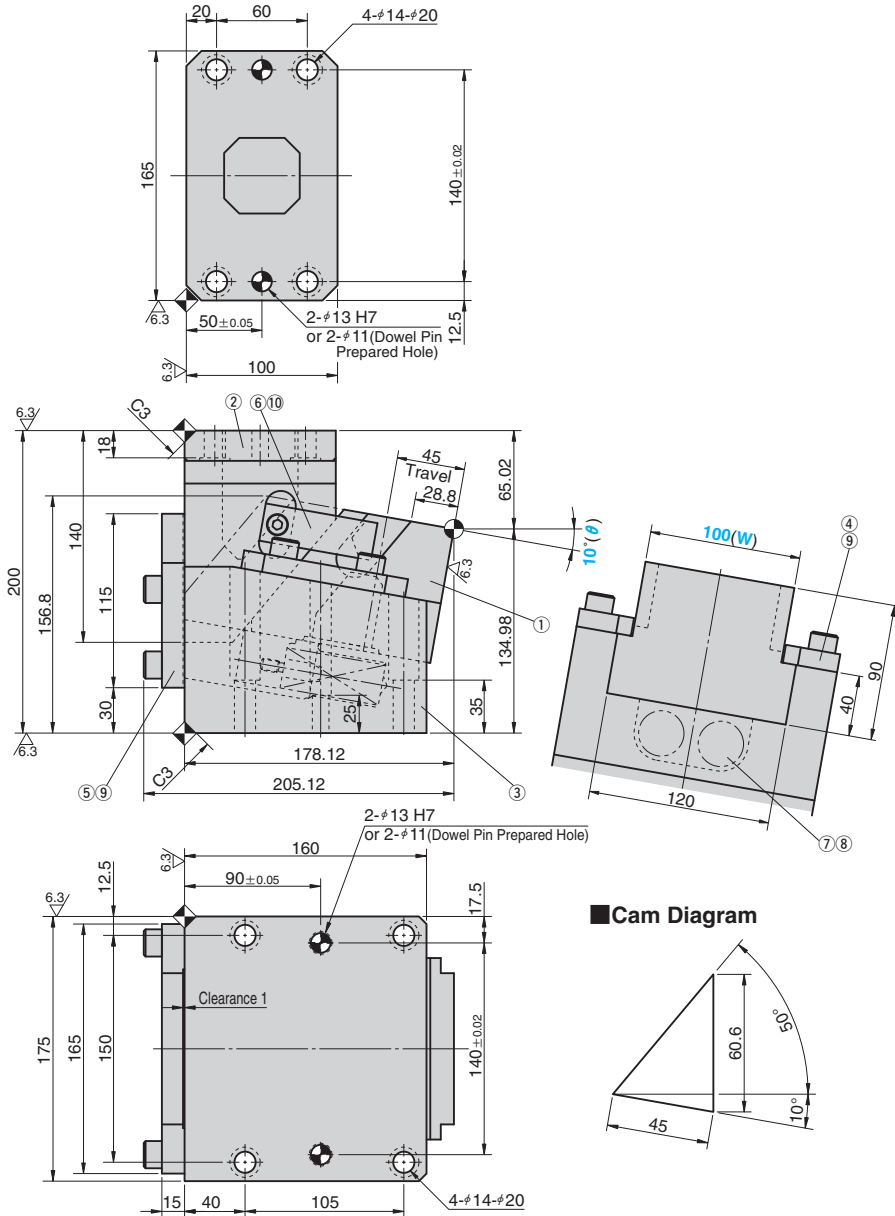

Working Force kN(tonf)		Spring Force N(kgf)		Slider Weight kg	Total Weight kg	Catalog No.	(W)	(θ)	Travel S
Standard Working Force (one million strokes)	Allowable Working Force (300,000 strokes)	Initial Load	Final Load						
39.2 (4.0)	78.4 (8.0)	263.2 (26.9)	1109.2 (113.3)	7.0	33.0	SKCA SKC	100	10	45

Order **Catalog No.** SKCA - **(W)** 100 - **(θ)** 10 - **S** 45

Option **Option Code** N12 **Specification**
 The dowel pin holes for the cam holder and cam driver are changed to #12H7. (only SKCA)

Order SKCA100 - 10 - 45 - N12

Refer to page 552 for detailed specifications of tapped holes and dowel pin holes (prepared hole, finish hole) for retainer.

Table of Components

No.	Description	Qty	Material and Remark
①	Cam Slider	1	FC250 with Graphite
②	Cam Driver	1	FC250 with Graphite
③	Cam Holder	1	FC250
④	Upper Plate	2	S45C Copper Powder Sintered (#220)
⑤	Stopper Plate	1	SS400(1020)
⑥	Positive Return Follower	2	S45C(1045)
⑦	Spring Guide Pin	2	#12×40
⑧	Coil Spring	2	TF27-125
⑨	Hexagon Socket Head Bolt	8	SCM435 M12×35
⑩	Hexagon Socket Head Bolt	2	SCM435 M8×25

Spring Diagram

(Stripping Force at punch retraction of 5mm)

- *Spring used TF27-125(2 pieces)
- *Spring constant 9.4N/mm (0.96kgf/mm)

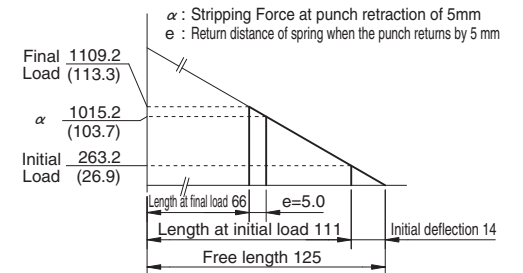

Space for removing

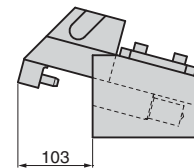

SKCA100 - 10 - 70 (Dowel Pin Hole Finished)
 SKC 100 - 10 - 70 (Dowel Pin Prepared Hole)

⚠ Tolerance are from dowel pin finished hole.

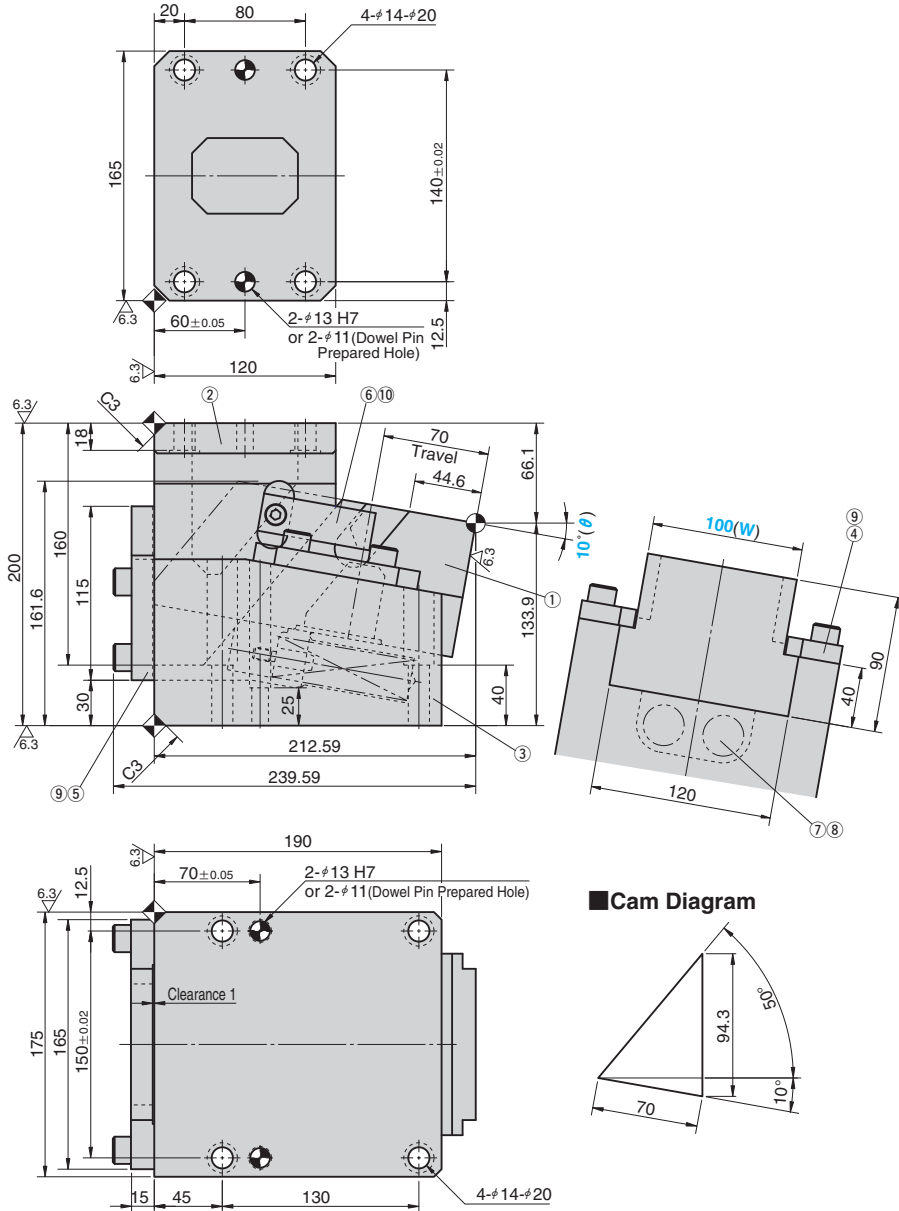

Cam Diagram

Working Force kN(tonf)		Spring Force N(kgf)		Slider Weight kg	Total Weight kg	Catalog No.	(W)	(θ)	Travel S
Standard Working Force (one million strokes)	Allowable Working Force (300,000 strokes)	Initial Load	Final Load						
39.2 (4.0)	78.4 (8.0)	197.2 (20.0)	1149.2 (116.6)	10.0	38.0	SKCA SKC	100	10	70

Order **Catalog No.** SKCA - **(W)** 100 - **(θ)** 10 - **S** 70

Option **Option Code** N12 **Specification** The dowel pin holes for the cam holder and cam driver are changed to φ12H7. (only SKCA)

Order SKCA100 - 10 - 70 - N12

Refer to page 552 for detailed specifications of tapped holes and dowel pin holes (prepared hole, finish hole) for retainer.

Table of Components

No.	Description	Qty	Material and Remark
①	Cam Slider	1	FC250 with Graphite
②	Cam Driver	1	FC250 with Graphite
③	Cam Holder	1	FC250
④	Upper Plate	2	S45C Copper Powder Sintered (#220)
⑤	Stopper Plate	1	SS400(1020)
⑥	Positive Return Follower	2	S45C(1045)
⑦	Spring Guide Pin	2	φ12×40
⑧	Coil Spring	2	TF27-175
⑨	Hexagon Socket Head Bolt	8	SCM435 M12×35
⑩	Hexagon Socket Head Bolt	2	SCM435 M8×25

Spring Diagram

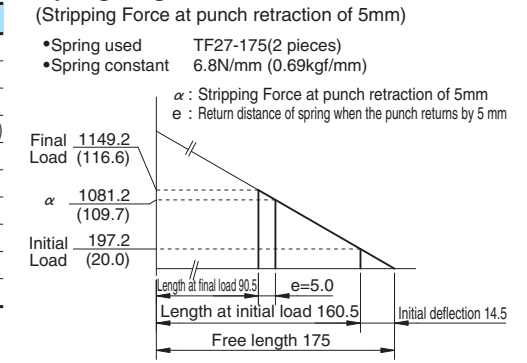

Space for removing

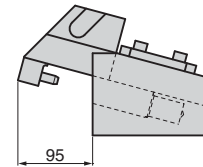

Die Mounted Cam Unit

FOR PIERCE AND FLANGE

CAD FILE

SKCA100 - 15 - 45 (Dowel Pin Hole Finished)
SKC 100 - 15 - 45 (Dowel Pin Prepared Hole)

⚠ Tolerance are from dowel pin finished hole.

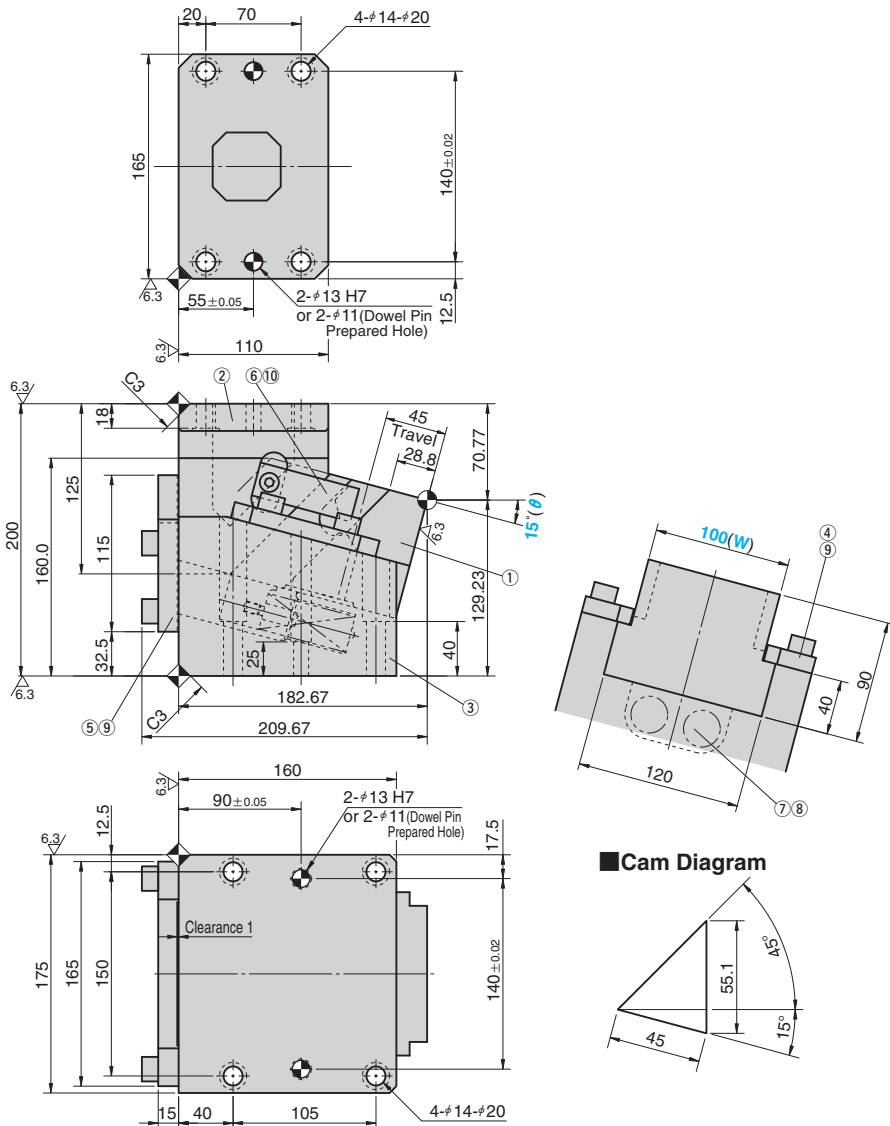

Cam Diagram

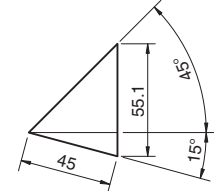

Working Force kN(tonf)		Spring Force N(kgf)		Slider Weight kg	Total Weight kg	Catalog No.	(W)	(θ)	Travel S
Standard Working Force (one million strokes)	Allowable Working Force (300,000 strokes)	Initial Load	Final Load						
39.2 (4.0)	78.4 (8.0)	263.2 (26.9)	1109.2 (113.3)	7.0	33.0	SKCA SKC	100	15	45

Order **Catalog No.** SKCA - **(W)** 100 - **(θ)** 15 - **S** 45

Option **Option Code** N12 **Specification** The dowel pin holes for the cam holder and cam driver are changed to #12H7. (only SKCA)

Order SKCA100 - 15 - 45 - N12

Refer to page 552 for detailed specifications of tapped holes and dowel pin holes (prepared hole, finish hole) for retainer.

Table of Components

No.	Description	Qty	Material and Remark
①	Cam Slider	1	FC250 with Graphite
②	Cam Driver	1	FC250 with Graphite
③	Cam Holder	1	FC250
④	Upper Plate	2	S45C Copper Powder Sintered (#220)
⑤	Stopper Plate	1	SS400(1020)
⑥	Positive Return Follower	2	S45C(1045)
⑦	Spring Guide Pin	2	φ12×40
⑧	Coil Spring	2	TF27-125
⑨	Hexagon Socket Head Bolt	8	SCM435 M12×35
⑩	Hexagon Socket Head Bolt	2	SCM435 M8×25

Spring Diagram

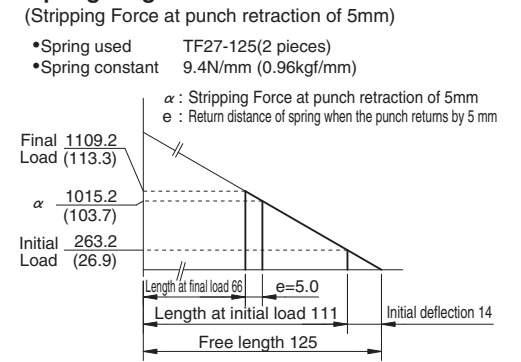

Space for removing

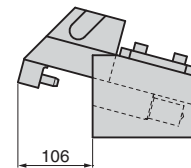

Die Mounted Cam Unit

FOR PIERCE AND FLANGE

CAD FILE

SKCA100 - 15 - 70 (Dowel Pin Hole Finished)
 SKC 100 - 15 - 70 (Dowel Pin Prepared Hole)

⚠ Tolerance are from dowel pin finished hole.

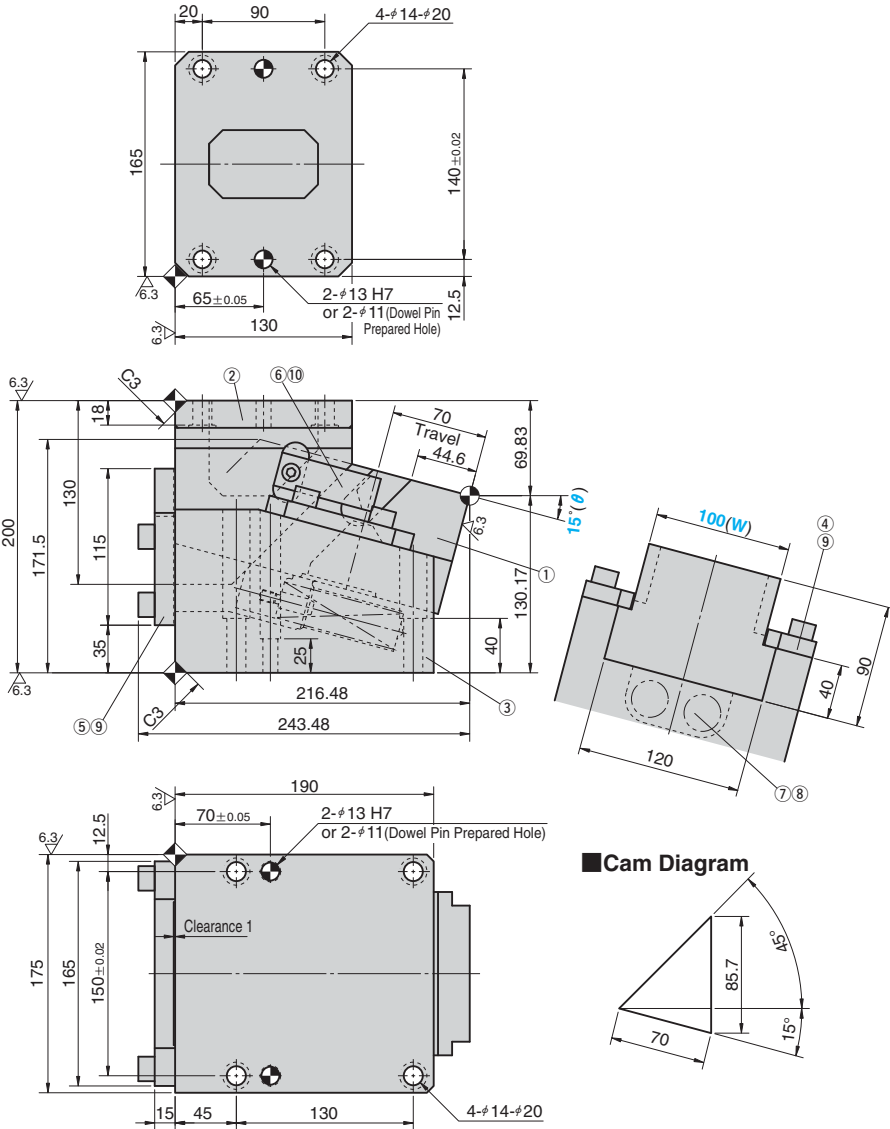

Working Force kN(tonf)		Spring Force N(kgf)		Slider Weight kg	Total Weight kg	Catalog No.	(W)	(θ)	Travel S
Standard Working Force (one million strokes)	Allowable Working Force (300,000 strokes)	Initial Load	Final Load						
39.2 (4.0)	78.4 (8.0)	197.2 (20.0)	1149.2 (116.6)	10.0	38.0	SKCA SKC	100	15	70

Order **Catalog No.** (W) - (θ) - S
 SKCA 100 - 15 - 70

Option **Option Code** **Specification**
 N12 The dowel pin holes for the cam holder and cam driver are changed to φ12H7. (only SKCA)

Order **SKCA100 - 15 - 70 - N12**

Refer to page 552 for detailed specifications of tapped holes and dowel pin holes (prepared hole, finish hole) for retainer.

Table of Components

No.	Description	Qty	Material and Remark
①	Cam Slider	1	FC250 with Graphite
②	Cam Driver	1	FC250 with Graphite
③	Cam Holder	1	FC250
④	Upper Plate	2	S45C Copper Powder Sintered (#220)
⑤	Stopper Plate	1	SS400(1020)
⑥	Positive Return Follower	2	S45C(1045)
⑦	Spring Guide Pin	2	φ12×40
⑧	Coil Spring	2	TF27-175
⑨	Hexagon Socket Head Bolt	8	SCM435 M12×35
⑩	Hexagon Socket Head Bolt	2	SCM435 M8×25

Spring Diagram

(Stripping Force at punch retraction of 5mm)

- Spring used TF27-175(2 pieces)
- Spring constant 6.8N/mm (0.69kgf/mm)

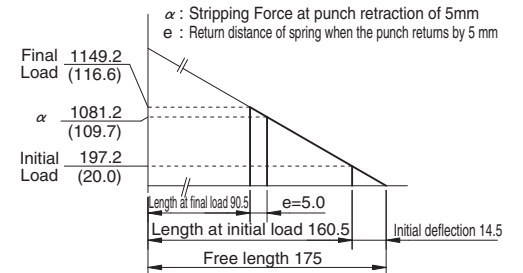

Space for removing

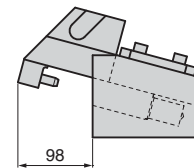

Die Mounted Cam Unit

FOR PIERCE AND FLANGE

CAD FILE

SKCA100-20-45 (Dowel Pin Hole Finished)
SKC 100-20-45 (Dowel Pin Prepared Hole)

⚠ Tolerance are from dowel pin finished hole.

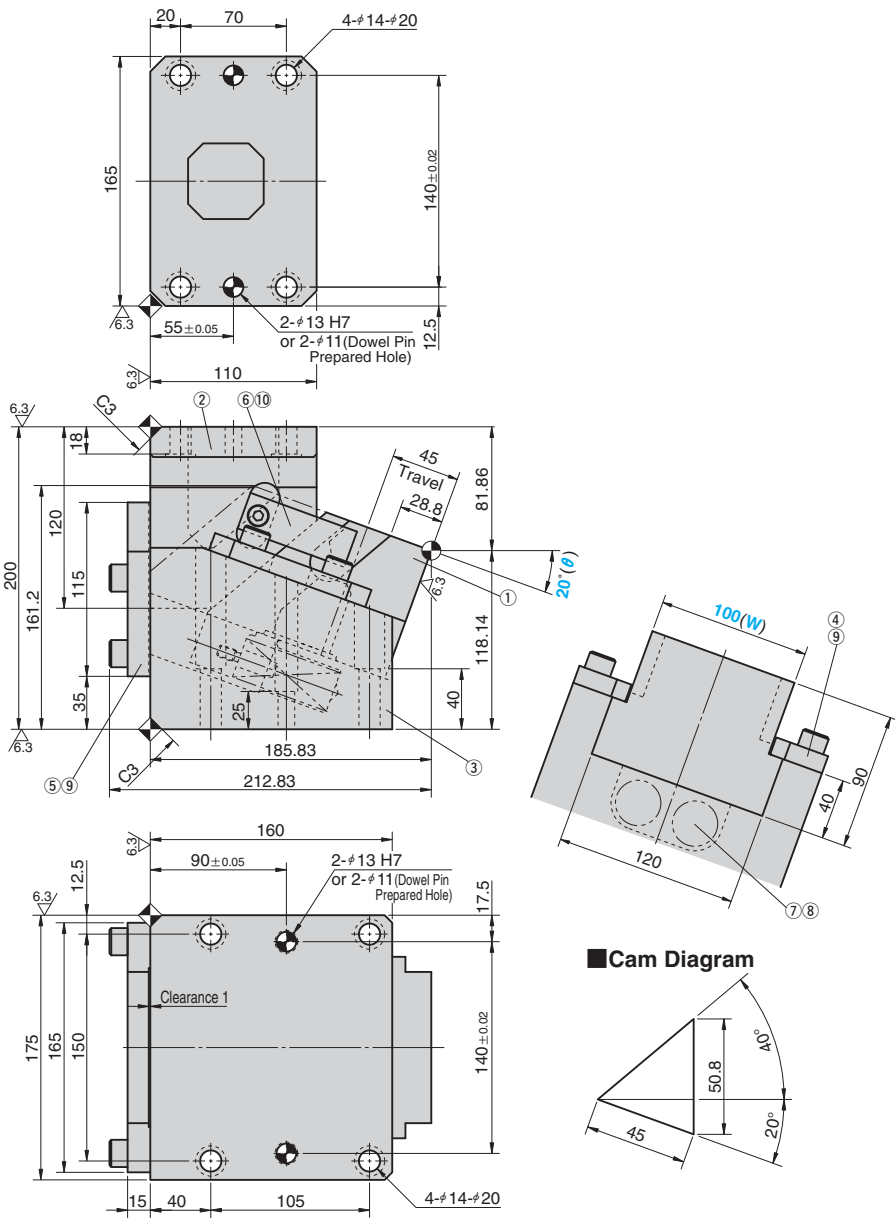

Working Force kN(tonf)		Spring Force N(kgf)		Slider Weight kg	Total Weight kg	Catalog No.	(W)	(θ)	Travel S
Standard Working Force (one million strokes)	Allowable Working Force (300,000 strokes)	Initial Load	Final Load						
39.2 (4.0)	78.4 (8.0)	263.2 (26.9)	1109.2 (113.3)	7.0	32.0	SKCA SKC	100	20	45

Order **Catalog No.** SKCA - **(W)** 100 - **(θ)** 20 - **S** 45

Option **Option Code** N12 **Specification** The dowel pin holes for the cam holder and cam driver are changed to φ12H7. (only SKCA)

Order SKCA100-20-45-N12

Refer to page 552 for detailed specifications of tapped holes and dowel pin holes (prepared hole, finish hole) for retainer.

Table of Components

No.	Description	Qty	Material and Remark
①	Cam Slider	1	FC250 with Graphite
②	Cam Driver	1	FC250 with Graphite
③	Cam Holder	1	FC250
④	Upper Plate	2	S45C Copper Powder Sintered (#220)
⑤	Stopper Plate	1	SS400(1020)
⑥	Positive Return Follower	2	S45C(1045)
⑦	Spring Guide Pin	2	φ12×40
⑧	Coil Spring	2	TF27-125
⑨	Hexagon Socket Head Bolt	8	SCM435 M12×35
⑩	Hexagon Socket Head Bolt	2	SCM435 M8×25

Spring Diagram

(Stripping Force at punch retraction of 5mm)

- Spring used TF27-125(2 pieces)
- Spring constant 9.4N/mm (0.96kgf/mm)

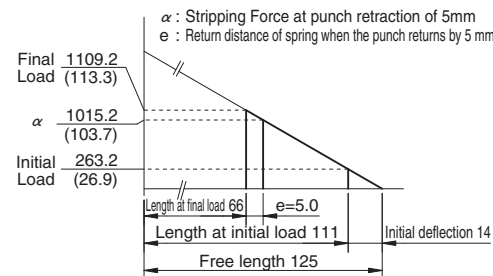

Space for removing

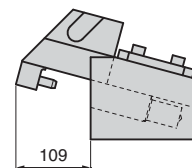

SKCA100 - 20 - 70 (Dowel Pin Hole Finished)
 SKC 100 - 20 - 70 (Dowel Pin Prepared Hole)

⚠ Tolerance are from dowel pin finished hole.

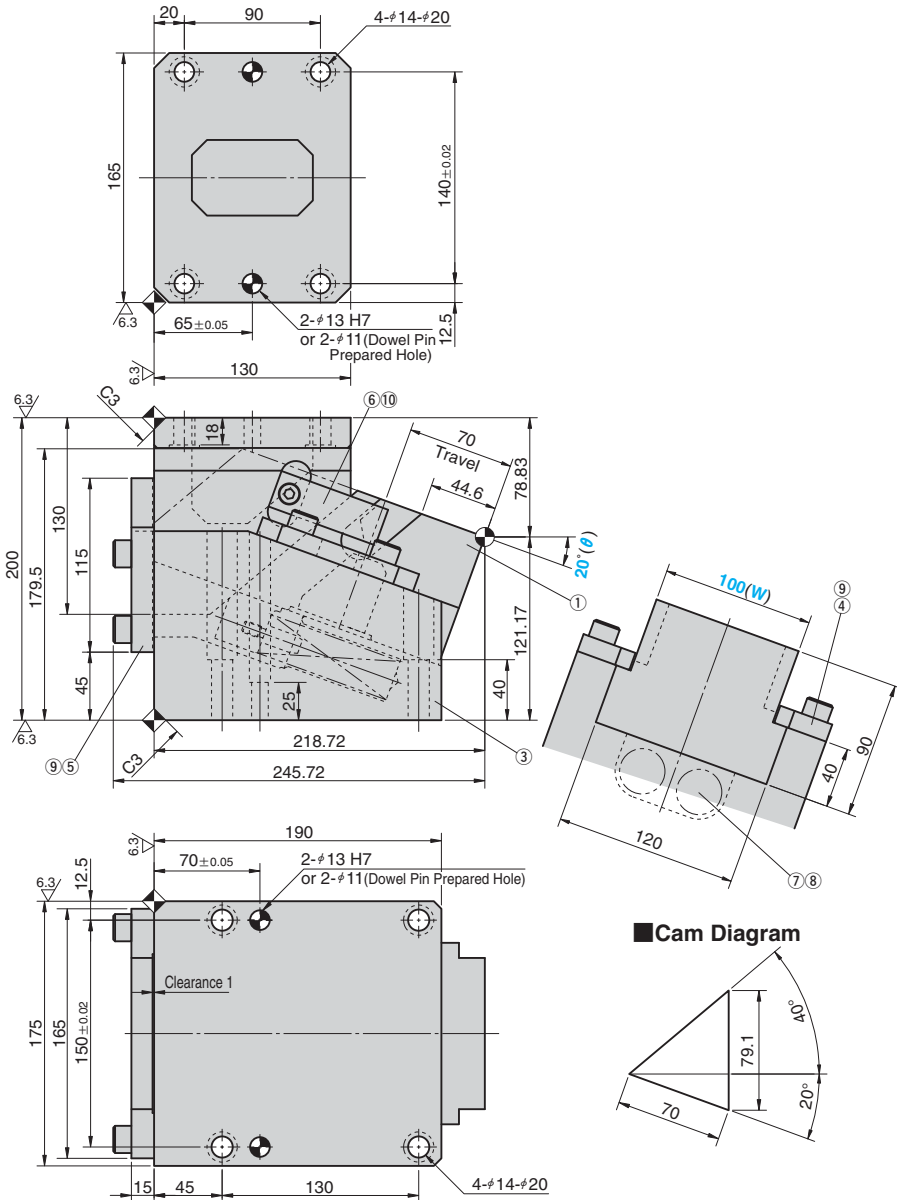

Working Force kN(tonf)		Spring Force N(kgf)		Slider Weight kg	Total Weight kg	Catalog No.	(W)	(θ)	Travel S
Standard Working Force (one million strokes)	Allowable Working Force (300,000 strokes)	Initial Load	Final Load						
39.2 (4.0)	78.4 (8.0)	197.2 (20.0)	1149.2 (116.6)	10.0	39.0	SKCA SKC	100	20	70

Order **Catalog No.** (W) - (θ) - S
 SKCA 100 - 20 - 70

Option **Option Code** **Specification**
 N12 The dowel pin holes for the cam holder and cam driver are changed to φ12H7. (only SKCA)

Order **SKCA100 - 20 - 70 - N12**

Refer to page 552 for detailed specifications of tapped holes and dowel pin holes (prepared hole, finish hole) for retainer.

Table of Components

No.	Description	Qty	Material and Remark
①	Cam Slider	1	FC250 with Graphite
②	Cam Driver	1	FC250 with Graphite
③	Cam Holder	1	FC250
④	Upper Plate	2	S45C Copper Powder Sintered (#220)
⑤	Stopper Plate	1	SS400(1020)
⑥	Positive Return Follower	2	S45C(1045)
⑦	Spring Guide Pin	2	φ12×40
⑧	Coil Spring	2	TF27-175
⑨	Hexagon Socket Head Bolt	8	SCM435 M12×35
⑩	Hexagon Socket Head Bolt	2	SCM435 M8×25

Spring Diagram

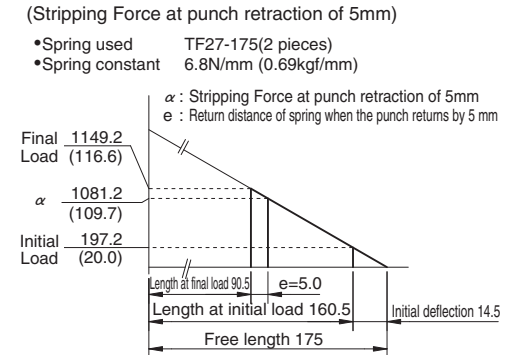

Space for removing

