

Shim Plate

FOR SLIDE PLATE

RoHS

SHMS

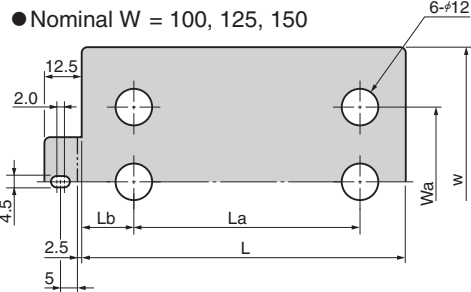
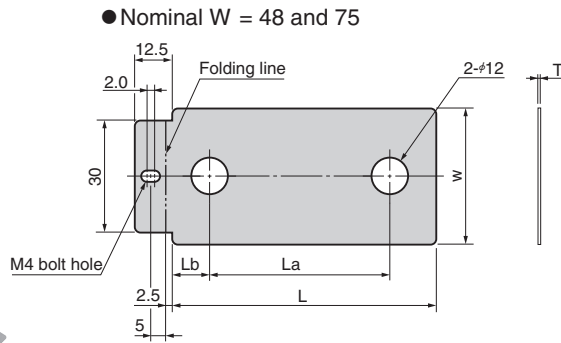

| T tolerance | |
|-------------|-----------|
| T | tolerance |
| 0.05 | ±0.01 |
| 0.1 0.2 | ±0.02 |
| 0.3 | |

Material : SUS304 (L 11 A 304)

For Operation

- This is common for wear plate thickness of 10 and 20 mm, and 2 and 4 holes.
- Drill tapped holes (M4) on the wear plate at the folding area so that the shim plate will not be lost.

EX Example

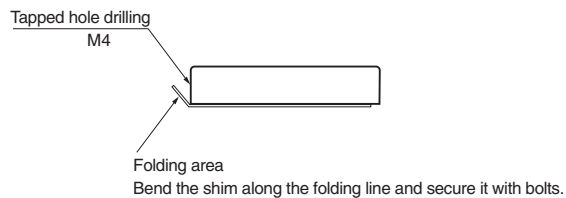

| Wa | La | Lb | w | L | Catalog No. | Nominal (Slide plate) | | Thickness T |
|-----|-----|------|-----|-----|-------------|-----------------------|-----|-------------|
| | | | | | | W | L | |
| | 45 | 12.5 | | 70 | | | 75 | |
| | 50 | | | 95 | | | 100 | |
| | 75 | | 38 | 120 | | 48 | 125 | |
| | 100 | | | 145 | | | 150 | |
| | 150 | | | 195 | | | 200 | |
| | 25 | | | 70 | | | 75 | |
| | 50 | | | 95 | | | 100 | |
| | 75 | | 65 | 120 | | 75 | 125 | 0.05 |
| | 100 | | | 145 | | | 150 | |
| | 150 | | | 195 | | | 200 | |
| | 50 | | | 95 | SHMS | | 100 | 0.1 |
| | 75 | | | 120 | | | 125 | 0.2 |
| | 100 | 22.5 | 90 | 145 | | 100 | 150 | 0.3 |
| | 150 | | | 195 | | | 200 | |
| 50 | 200 | | | 245 | | | 250 | |
| | 75 | | | 120 | | | 125 | |
| | 100 | | | 145 | | | 150 | |
| | 150 | | 115 | 195 | | 125 | 200 | |
| | 200 | | | 245 | | | 250 | |
| 100 | 100 | | | 145 | | | 150 | |
| | 150 | | 140 | 195 | 150 | 200 | | |
| | 200 | | | 245 | | 250 | | |



Order

| | | | | | |
|-------------|----|---|-----|---|-----|
| Catalog No. | W | - | L | - | T |
| SHMS | 48 | - | 125 | - | 0.1 |

For Order:

When ordering the 0.05 or the 0.1 shim plate sizes, the quantity of shim plates shipped is 10 per size. Single plates each can be ordered for 0.2 and 0.3 shim plates.