

TWX

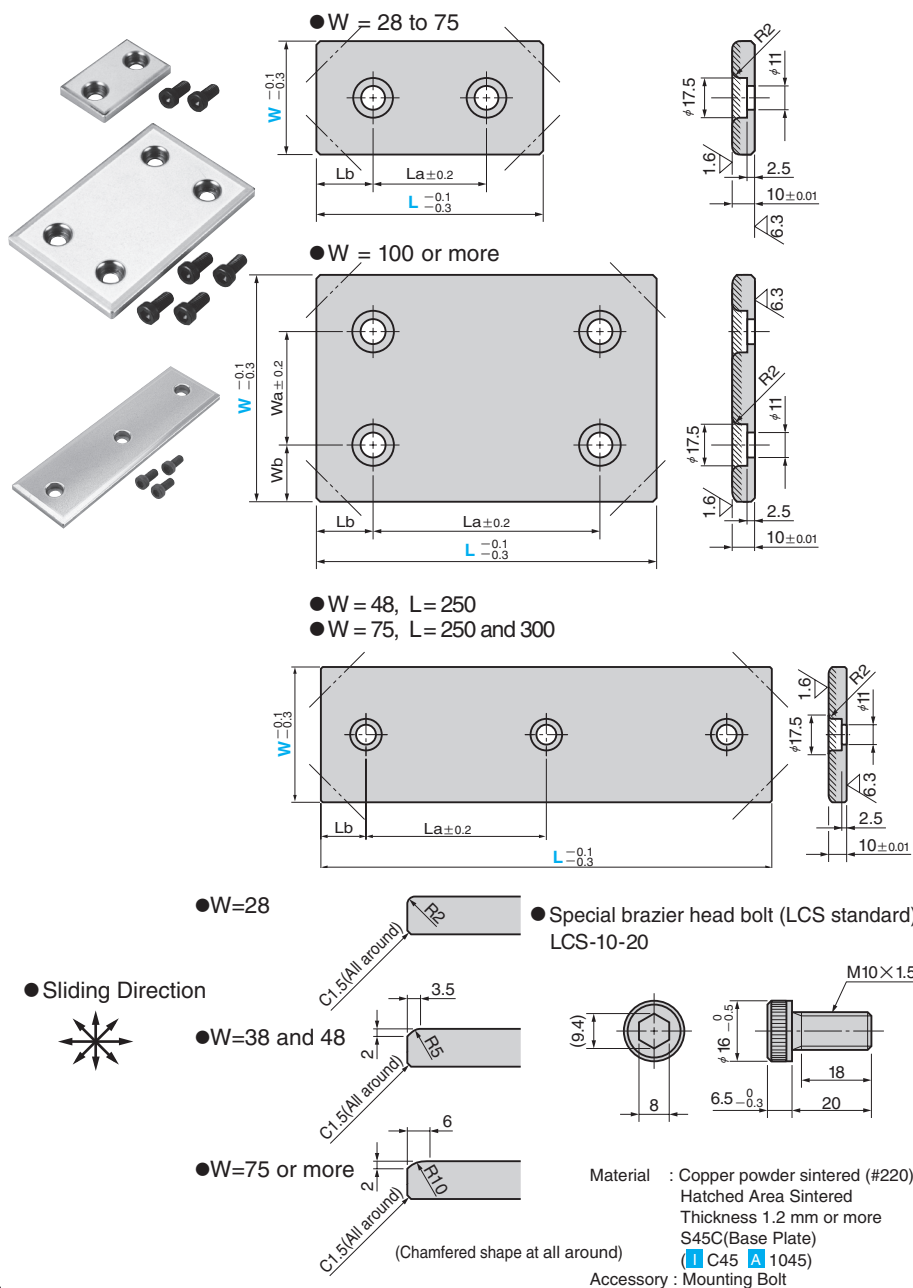

Wa	Wb	La	Lb	Catalog No.	W	L
		45	15			75
		50			28	100
		75	25			125
		100				150
		45	15			75
		50			38	100
		75	25			125
		100				150
		45	15			75
		50			48	100
		75	25			125
		100	50			200
						250
		25				75
		50				100
		75	25			125
		100		TWX	75	150
		150				200
		100				250
		100	50			300
		50				100
		75				125
50	25	100	25		100	150
		150				200
		200	50			300
75		75				125
		100				150
50	37.5	150	25		125	200
		200	50			300
		100				150
100	25	150	25		150	200
		200				250



Order

Catalog No.	W	-	L
TWX	38	-	150



Option

Option Code	Specification
CM	With chamfering on corners for relief (4 corners). Please instruct chamfering (ex.CM17 (6≤C<W/2, Max C17) size when ordering.

\*CM Specification



Order

TWX 75 - 100 - CM17