

MCSRG (FC Type)
MCSRW (Bronze Type)

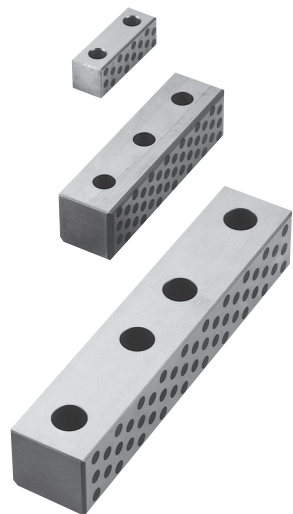

● W = 25 (MCSRG Only)

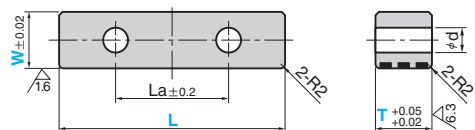

● W ≥ 40 L = 150 and 200

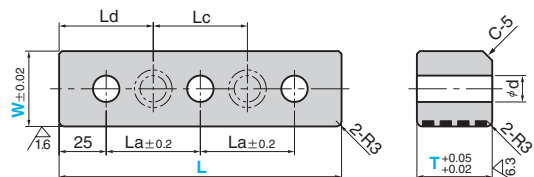

● W ≥ 40 L = 250

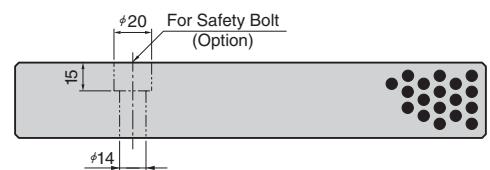
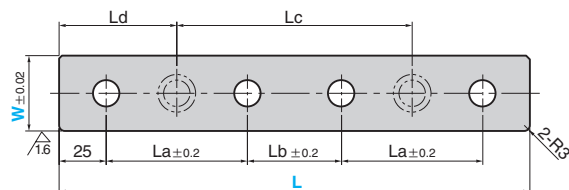

● Sliding Direction



Material
MCSRG FC250 with Graphite
MCSRW (I 185-88E A A48-83) Bronze with Graphite



Option

Option Code	Specification
ZA	Bolt holes to prevent falling of cam side block are drilled. W=40 and 50 only.



Order MCSRG 50 - 200 - 45 - ZA

● Bolt Position

L	Lc	Ld
150	50	50
200	75	62.5
250	125	62.5

La	Lb	d	Catalog No.	W	L	T
45			MCSRG	25	75	
50		11			100	
75					125	25
100					150	
50					150	
75					200	30
50	50	14		40	250	
50					150	
75	50				200	40
50					250	
75			MCSRG		150	45
50			MCSRW		250	
75					150	
50	50	20		50	200	55
75					250	
50					150	60
75	50				250	
50					150	
75					200	70
50	50				250	



Order

Catalog No. W - L - T
MCSRG 40 - 200 - 30



Example

● When this Side Guide is used together with Slide Plate.

Wear Plate Thickness	MCSRG MCSRW Thickness T	Slide Plate Thickness
10	30	20
	45	35
	60	50
20	40	20
	55	35
	70	50

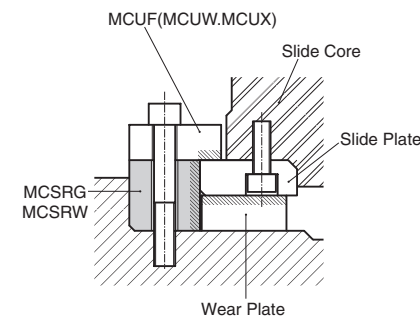

■ We are ready to accept requests or orders for special parts.