

SCUC (For Core Pin Mounting Type)

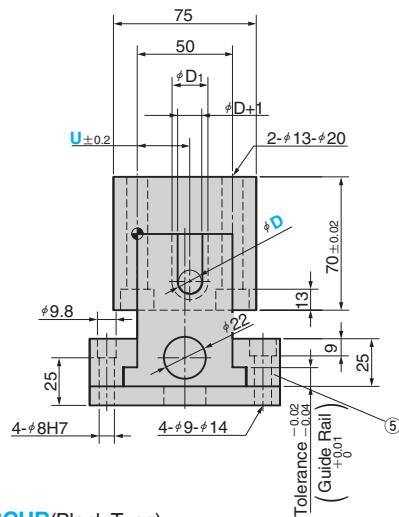

SCUB (Blank Type)

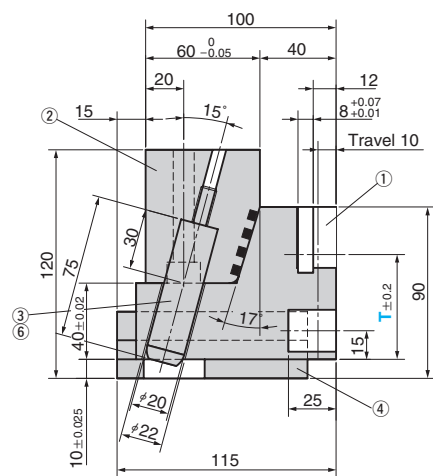
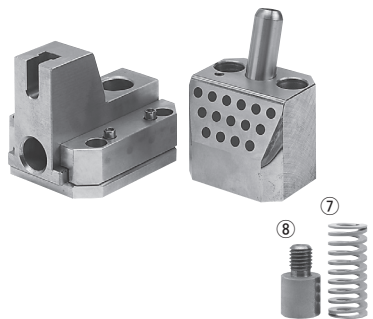
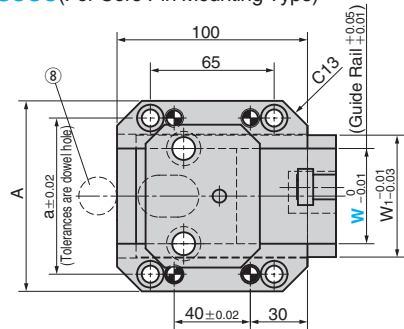
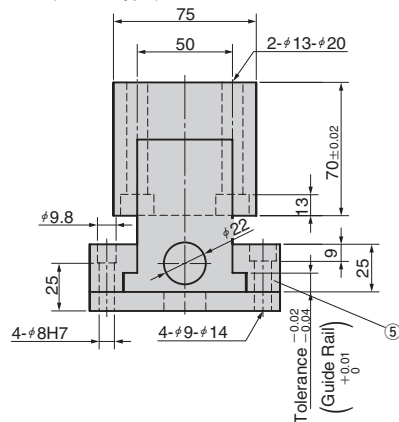

Table of Components

No.	Description	Qty	Material and Remark
①	Slide Core	1	S55C
②	Locking Block	1	S55C HQI HRC55~ Oilless Type
③	Angular Pin	1	SUJ2 HQI HRC58~
④	Lower Plate	1	Bronze with Graphite
⑤	Guide Rail (SGLWN)	2	Bronze with Graphite
⑥	Hexagonal Socket Head Bolt	1	SCM435 M8×85
⑦	Coil Spring	1	TF20-45(Accessory)
⑧	Stopper (STB)	1	S45C(Accessory)

A	a	W ₁	Catalog No.	W	D	T Increments of 0.1mm	U Increments of 0.1mm
85	67	49	SCUC	35	10	40.0~70.0	D ≤ U ≤ W - D
100	82	64	SCUB	50	13		
					16		



Order

Catalog No.	W	D	T	U
SCUC	50	13	48.5	27.6
SCUB	35			

D₁ Dimension

D	D ₁
10	15
13	18
16	21

- ⚠ Indicate only dimension W for the SCUB type.
- Material of the slide core can be changed. Please contact the Sales Dept.

For details of the guide rail (⑤ SGLWN25-100), refer to page. 131.

For details of the locking block and the angular pin, refer to page. 125.

Spring Diagram

Consider the load carefully when a part is installed at the end of the slide core.

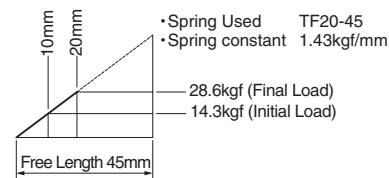

⑧ Stopper STB(Accessory)

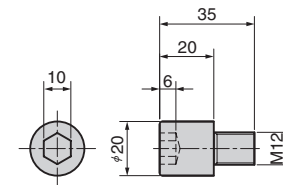

Material : S45C (T) C45 (A) 1045

Material detail

S55C (①・②) (T) C50 (A) 1055
 SUJ 2 (③) (T) B1 (A) 52100
 SCM435 (⑥) (T) 34CrMo4 (A) 4137
 S45C (⑧) (T) C45 (A) 1045



Example of using SCUC

