

Inclined Pin Type with Cooling Hole

FOR KOCUMR & KOCUFR

RoHS

KOPMR (Adjusting Type)

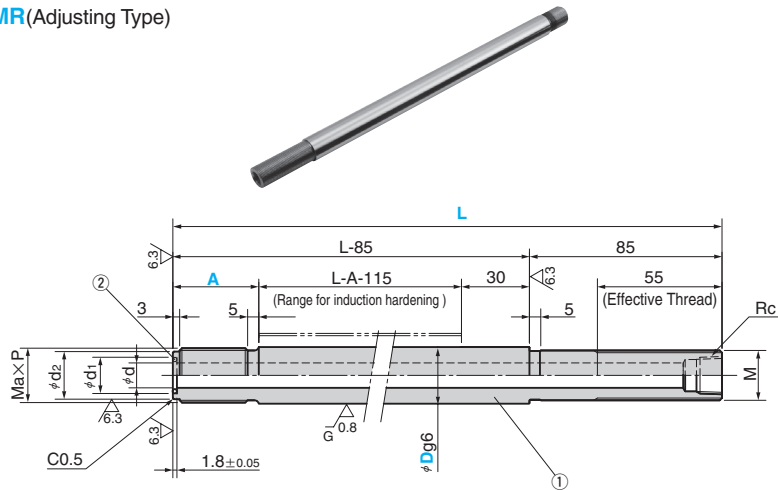

Induction hardening at $\text{HRC } 56$ to 60 , Depth: 1 mm or more

KOPFR (Fixing Type)

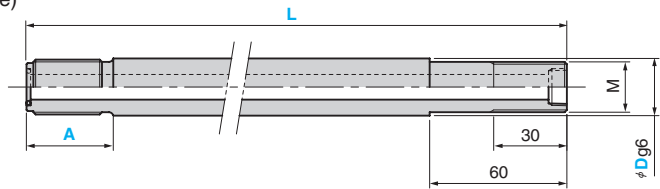

Material : ① SUJ 2 ② B1 A 52100

d	d ₁	d ₂	Ma×P	② O Ring	M	Rc	Catalog No.	D	L Increments of 0.1mm	A Increments of 1mm
12	17	20	M24×1.5	P12	M22×1.5	3/8	KOPMR	25	300 ≤ L ≤ 900	20 ≤ A ≤ 40
15	20	24	M28×1.5	P16	M27×1.5	1/2	KOPFR	30		



Order

Catalog No.	D	L	A
KOPMR	25	855.5	25
KOPFR	30	900.0	35

⚠ O ring is not attached

■ Built-in example



Please machine the detent after screwing in to core-block.

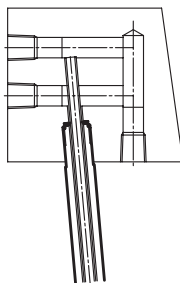
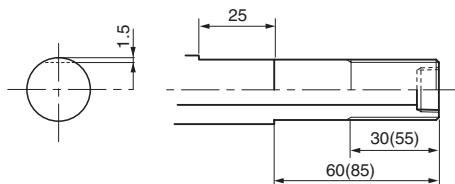

Manifold Set

FOR KOCUMR & KOCUFR

RoHS

KPMF

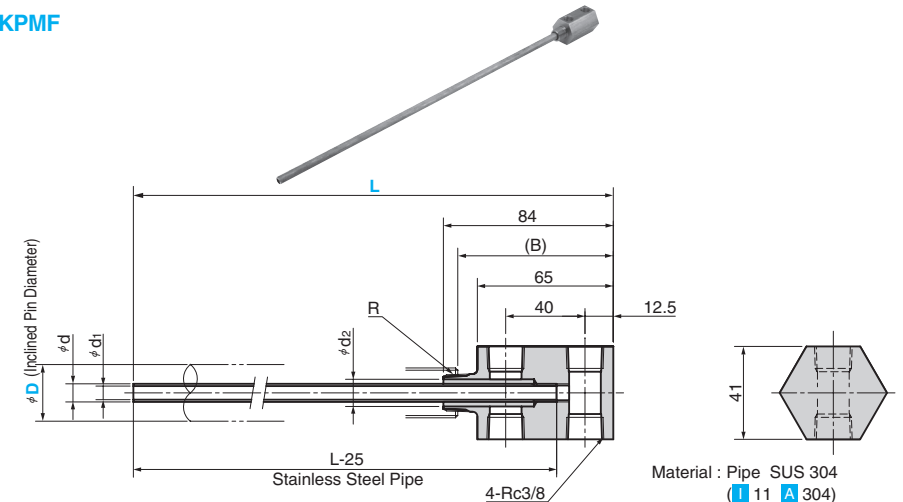

Material : Pipe SUS 304
① 11 A 304
Manifold C3604

d	d ₁	d ₂	(B)	R	Catalog No.	D	L Increments of 1mm
8	5	12	72	3/8	KPMF	25	300 ≤ L ≤ 1200
12	9	15	75	1/2		30	



Order

Catalog No.	D	L
KPMF	25	920

■ For Operation

Refer to the figure in the right and the table below for dimensions of parts when the manifold is used.

D	L	L _b	L _c	T	T _a	T _b
25	157	72	63	60	26	34
30	160	75	67	67	29	38

D	Pin Inner Diameter	d	d ₁
25	11	8	5
30	15	12	9

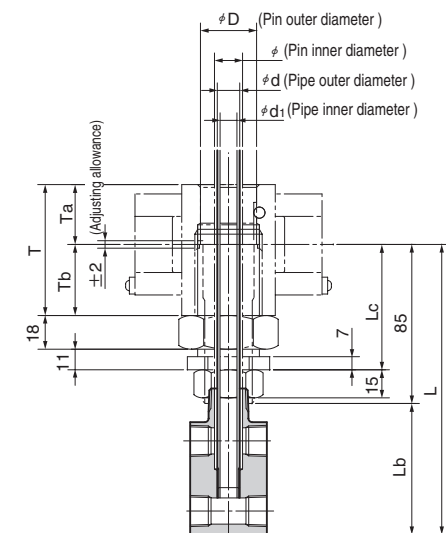

Loose Core Related Parts